

# Sanitary inspections

A sanitary inspection is an on-site inspection of a water supply to identify actual and potential sources of contamination. The physical structure and operation of the system and external environmental factors (such as latrine location) are evaluated. This information can be used to select appropriate remedial action to improve or protect the water supply.

Sanitary inspections should be carried out for all new sources of water before they are used for drinking water, and on a regular basis once the supply is ready for use, or the source is in operation. Inspections should be carried out by a suitably trained person using a simple, clear report form. These forms consist of a set of questions which have “yes” or “no” answers. The questions are structured so that “yes” answers indicate that there is a risk of contamination and “no” answers indicate that the particular risk is absent. Each “yes” answer scores one point and each “no” answer scores zero points. At the end of the inspection the points are added up, and the higher the total the greater the risk of contamination. The report forms are often pictorial to enable them to be easily understood.

The results of sanitary inspections and the remedial actions that need to be taken to improve conditions should be discussed with the community. In small water supplies it is often possible for community members to carry out most of the inspections themselves using a standard form. The information gathered can then be sent to the regional or national surveillance agency, which should also undertake a minimum of one annual inspection to check the reliability of the information.

Some sanitary inspections should be done in conjunction with water quality testing. This is called a sanitary survey. For further information on water quality testing, see Fact Sheets 2.29 to 2.33. Information on water quality testing, sanitary inspections and sanitary surveys can also be found in WHO *Guidelines for drinking water quality*, Volume III (Geneva, 1985).

An example of report forms for a sanitary survey of a dugwell is given below.

## SANITARY INSPECTION OF A DUGWELL

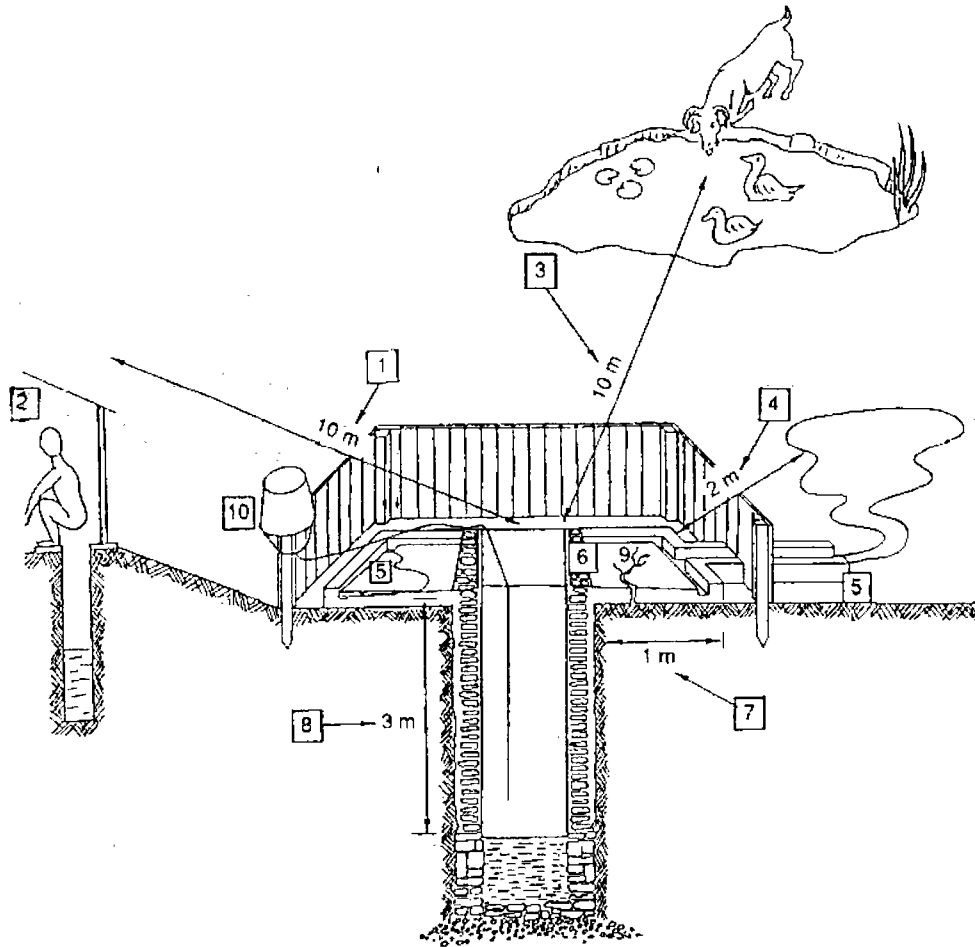
<b>General Information</b>	
<b>Location (Town, village, street, etc.):</b>	.....
<b>Water Authority/Local Committee:</b>	.....
<b>Date of Inspection:</b>	.....
<b>Water Sample No:</b>	..... <b>Faecal Coliform Grade:</b> .....

## SANITARY INSPECTION OF A DUGWELL

Code	Specific Information	Risk		Comments
		Yes	No	
1	Is there a latrine within 30 metres of the well?			
2	Is the nearest latrine on higher ground than the well?			
3	Is there any any other source of pollution within 30 metres of the well? (e.g. animal excreta, rubbish, etc)			
4	Is there any ponding of stagnant water within 2 metres of the cement floor of handpump?			
5	Is the handpump drainage channel faulty (e.g. broken, permitting ponding)? Does it need cleaning?			
6	Is there inadequate fencing around the installation, which would allow animals in?			
7	Is the cement floor less than 1 metre radius all around the handpump?			
8	Is there any ponding on the cement floor around the ?			
9	Are there any cracks on the cement floor around the well?			
10	Is a bucket also in use and left in a place where it could be contaminated?			
11	Is the handpump loose at the point of attachment to base (which could permit water to enter the casing)?			
12	Is the cover of the well not properly clean?			
13	Are the walls of the well inadequately sealed at any point for 3 metres below ground level?			



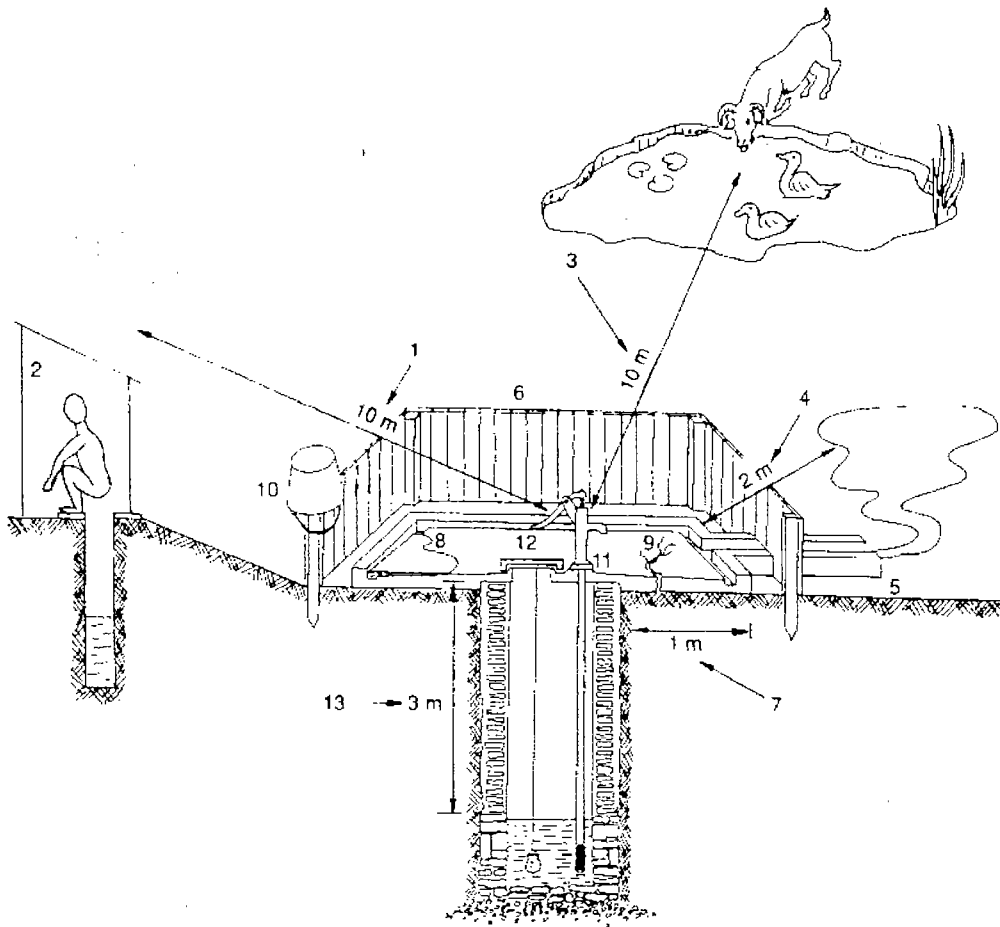
**Fact Sheet 2.1**



Circle all sanitary risks in red.

Advise pot chlorination where risk score is greater than 3.

Separate sheet along dotted line & give the diagram to the owner of the facility. \_\_\_\_\_

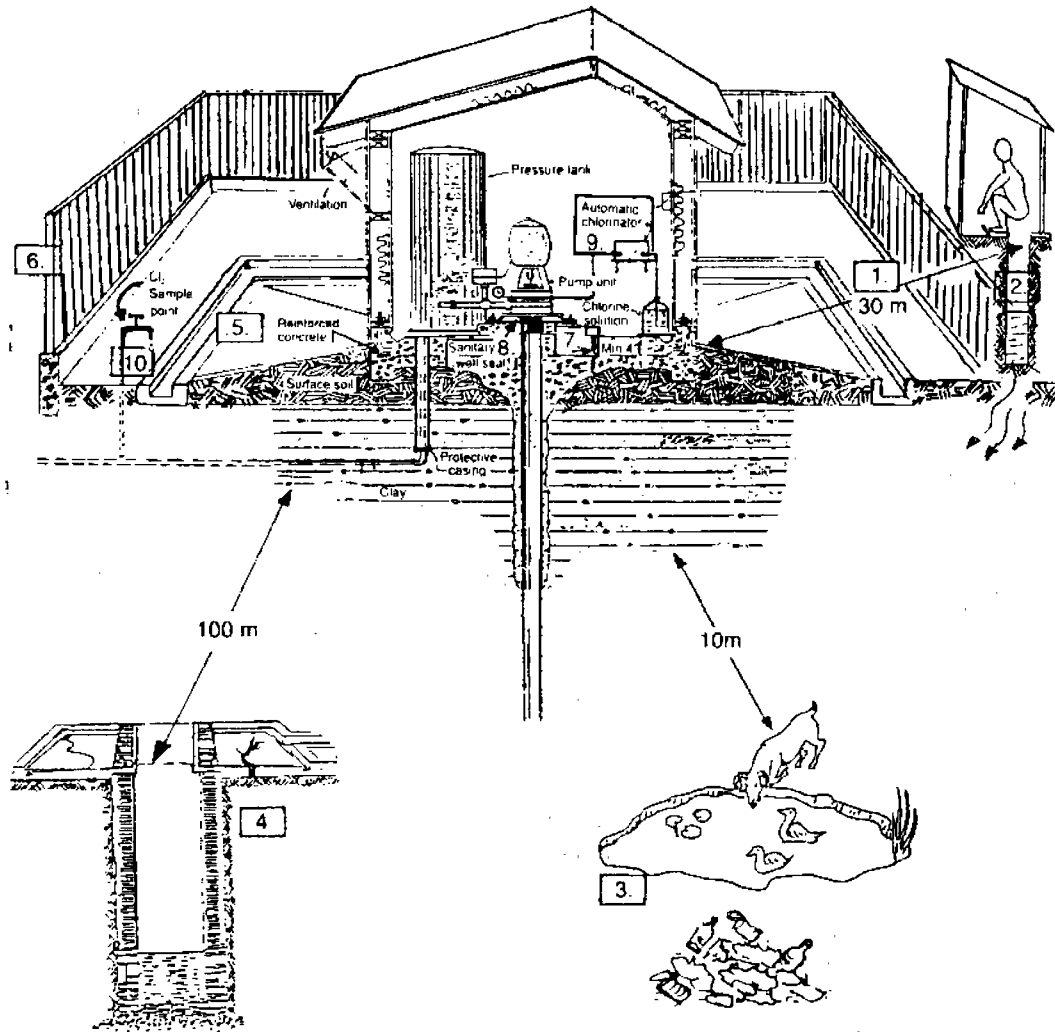


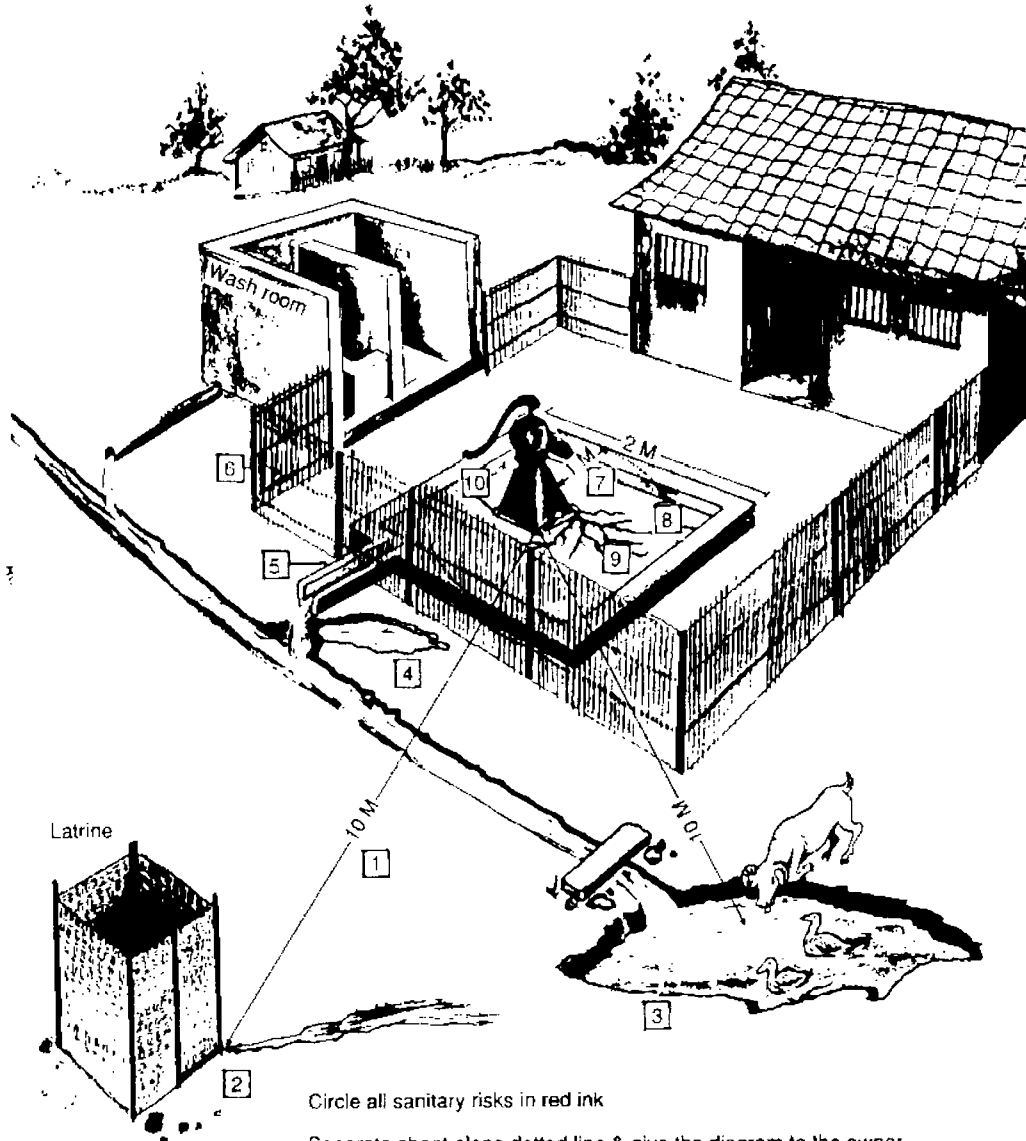
Circle all sanitary risks in red

Advise pot chlorination where risk score is greater than 3.

Separate sheet along dotted line & give the diagram to the owner of the \_\_\_\_\_ facility or the community representative.

**Fact Sheet 2.1**

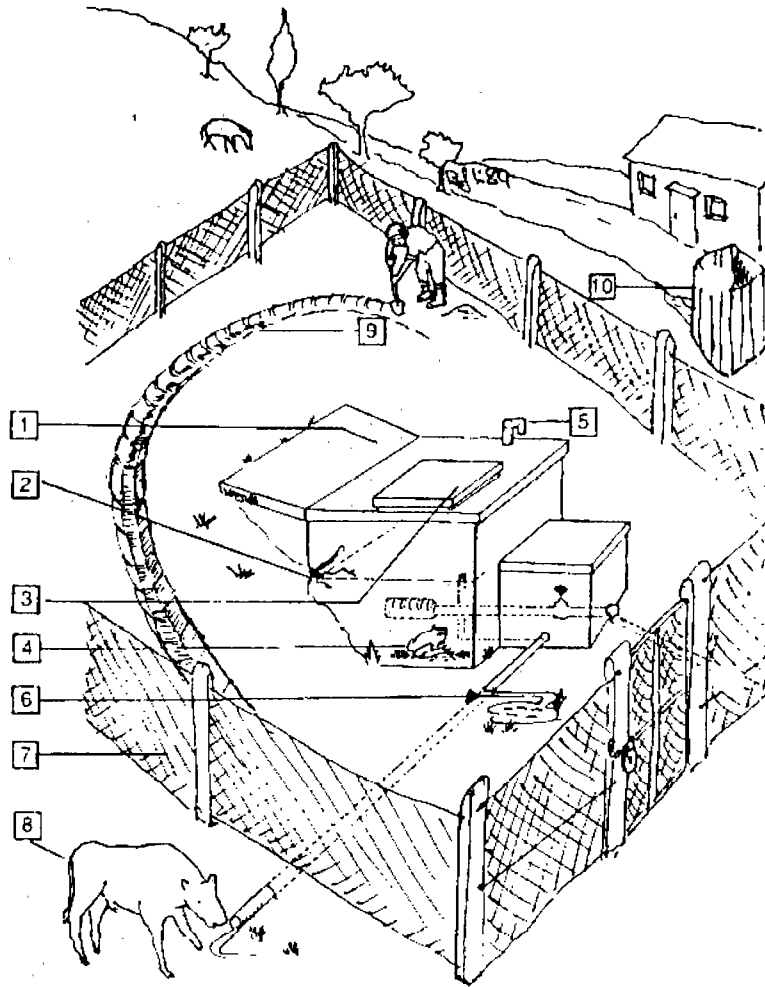




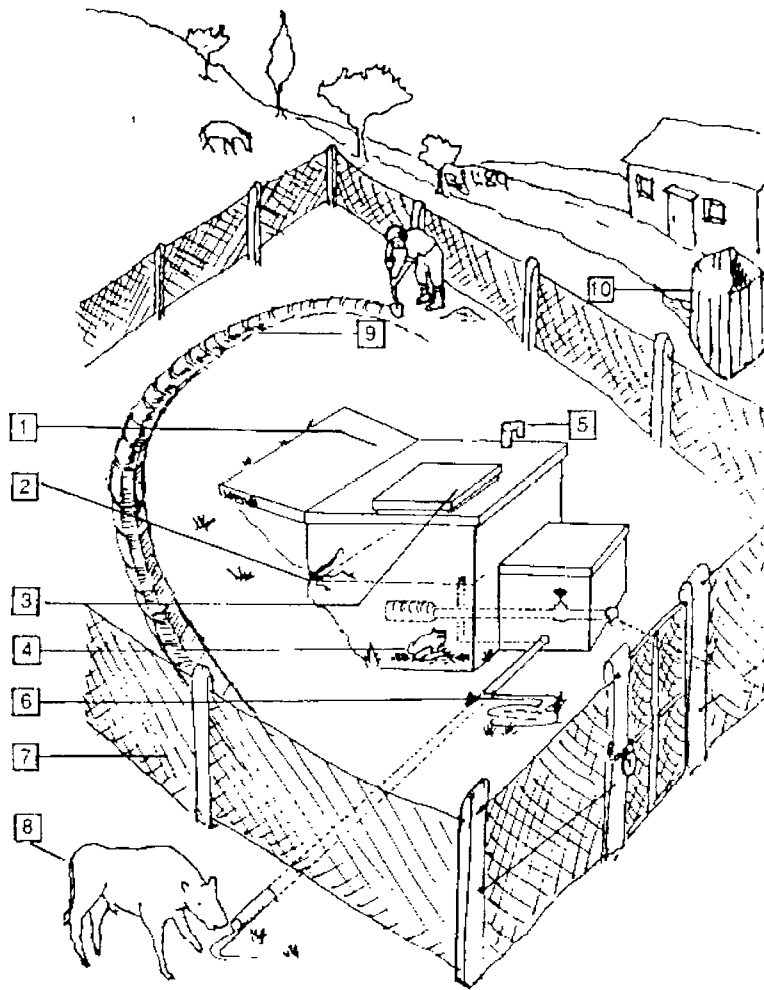
Circle all sanitary risks in red ink

Separate sheet along dotted line & give the diagram to the owner \_\_\_\_\_  
of the facility

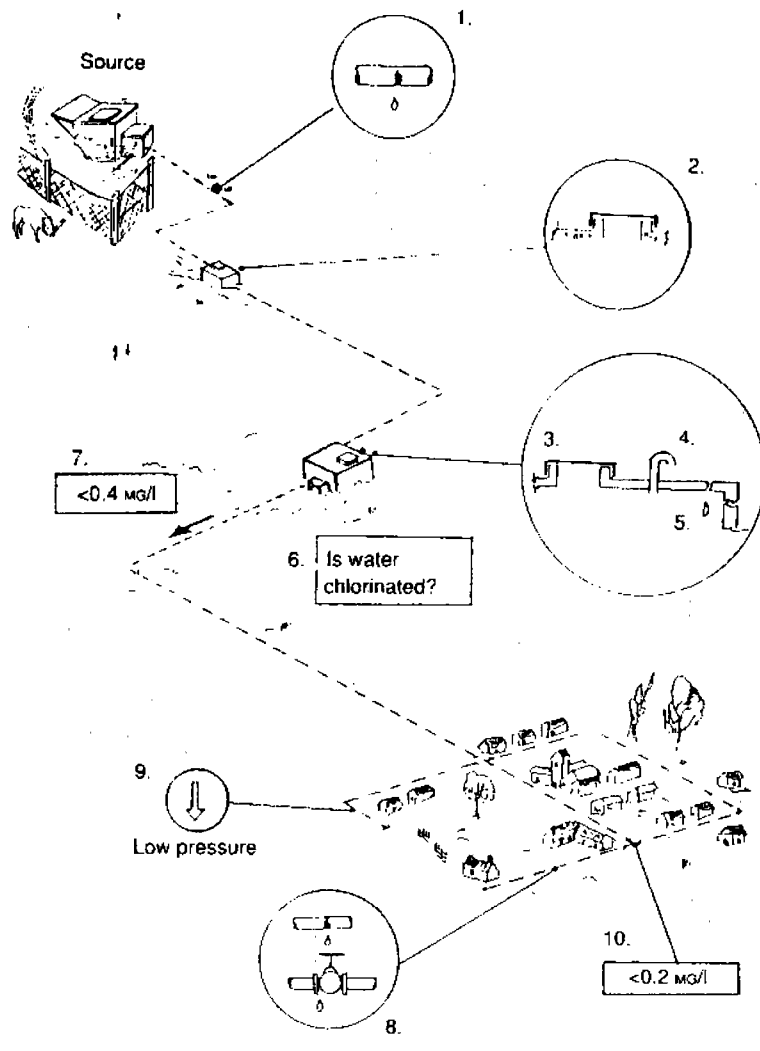
Shallow and deep handpumped tubewells

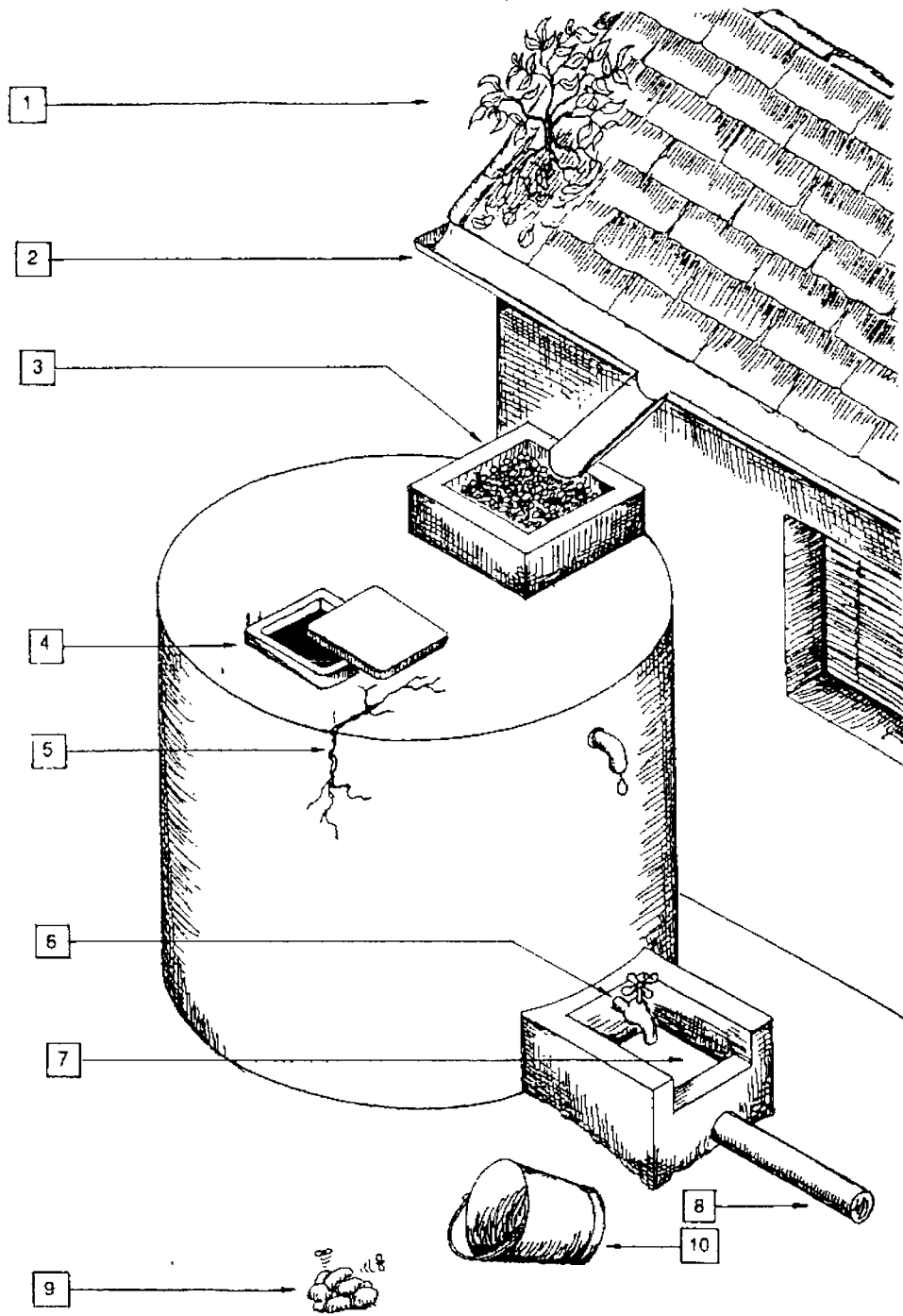






**Fact Sheet 2.1**





Rainwater catchment tank sanitary survey

# Dug wells

The dug well is a traditional method of obtaining water, which has been used for thousands of years. In its simplest form, a dug well is a shallow hole dug down into the water table.

Open, unprotected dug wells are common, especially in rural areas. They can become very contaminated from spilt water, animal excreta and objects thrown into the well. Dug wells in this condition pose a major risk to public health and help to spread diseases such as guinea worm, typhoid, cholera, hepatitis A and many diarrhoeal diseases.

Improved dug wells which are lined with concrete, covered and fitted with a secure water lifting device such as a pump or windlass can, however, provide safe drinking water.

---

## *Sanitary inspections of dug wells*

Sanitary inspections should be carried out on traditional and improved wells (see Fact Sheet 2.1). Where traditional wells are used, a sanitary inspection will indicate the main causes of contamination and how they can be eliminated through improvement. Improved wells, like all protected water supplies, require regular monitoring to ensure that an adequate and safe water supply is maintained.

The community should conduct sanitary inspections of dug wells approximately six times a year and at least once a year an external surveillance agency should make an inspection.

Where a community is served by a dug well, water quality tests should be carried out twice a year, once in the wet season and once in the dry season. If there are many household wells in a community, the surveillance agency should only test a few of the wells each year. The wells selected should be generally representative of wells in the community, so wells in locations where there are several wells nearby should be selected.

The results of the water quality analysis of the wells will show whether there is contamination, and the results of the sanitary inspections will enable the causes of contamination to be identified and eliminated.

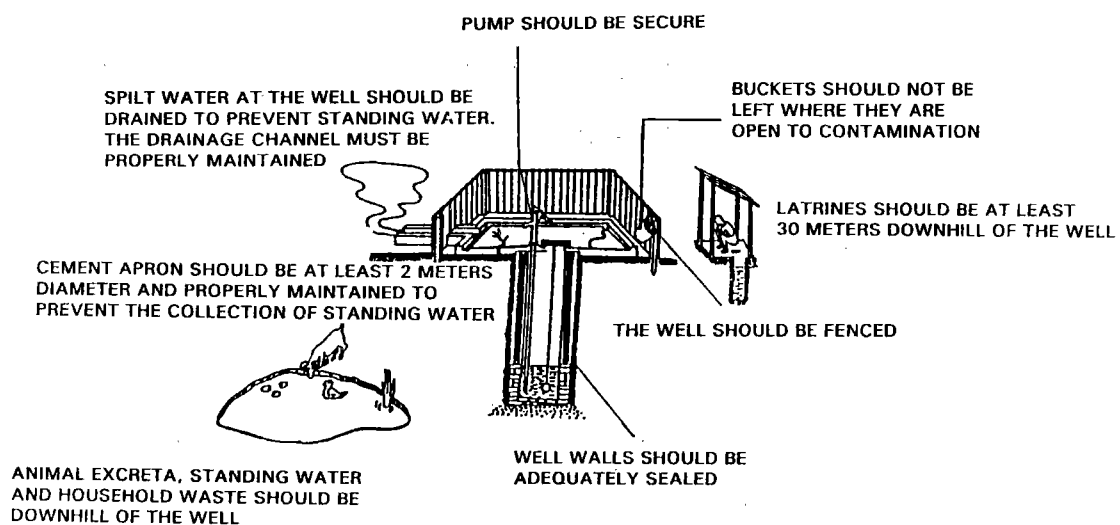
The key points to observe in a sanitary inspection of dug wells are shown in Figure 1. Sanitary inspections for all dug wells will follow the same format, but will differ slightly depending on the means of water withdrawal.

## *Building and upgrading dug wells*

Unprotected dug wells should be upgraded to provide clean safe water in order to protect the health of the community and to help prevent the spread of cholera and other diseases. Dug wells may be made deeper to produce more water.

Whenever possible, dug wells should be constructed or deepened during the dry season to ensure a year round water supply. It is important to ensure that the well will produce sufficient water, otherwise alternative, and possibly more contaminated, sources will be sought by the users.

A dug well can be upgraded to provide a clean water supply quite easily. This is done by building a well head with a cover, lining the top of the well shaft and fitting a hygienic system of lifting the water.



**Figure 1. Sanitary inspections of dug wells**

When new wells are constructed, the well shaft should be lined with concrete down to the water table and concrete caissons, or rings, should be sunk 3-4 m below the water level. This requires a reasonable level of skill, a fairly high capital input and some specialized drilling equipment. As a result, these wells are relatively expensive and are most likely to be constructed by organizations running large well-sinking programmes with trained technicians and engineers. *This Fact Sheet is only concerned with the upgrading of existing dug wells.*

### **Lining the well shaft**

When an existing unprotected well is to be upgraded it may not be possible to line the whole well shaft or to cast and sink caissons. It may only be possible to line the top of the shaft. These wells can be upgraded quite easily by one of two methods.

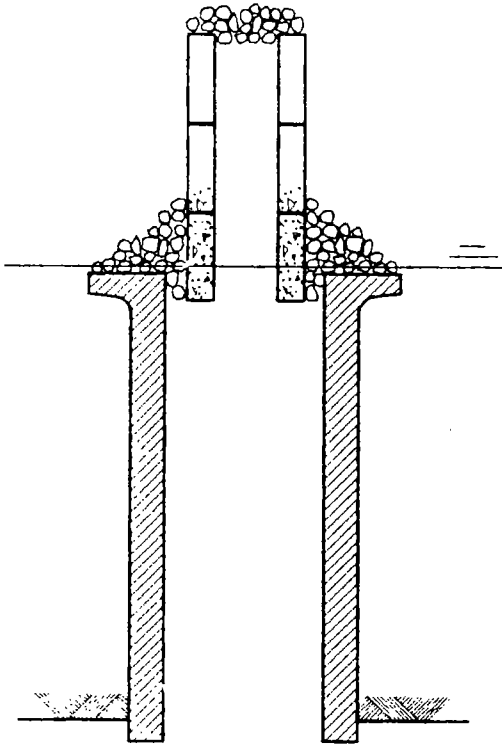
In stable soils with a fairly regular shaft, a watertight lining, drainage apron and cover slab should be constructed. At least the top 5 m of the well shaft should be lined. This will ensure that the top of the well is stable and not likely to col-

lapse. In addition, water entering the well will have been filtered during its passage through the top layers of soil and so will contain fewer pathogens, or contaminants than before.

The well can be lined with bricks and mortar, and plastered with a rich mortar mix. Alternatively, reinforced concrete can be cast behind a circular mould, but this method is more expensive and it may be more cost-effective to construct a new well.

The well should be dug out to a uniform diameter. Care should be taken to ensure that the base of the lining is wider than the unlined

shaft below it. It is a good idea to lay a supporting foundation that is wider than the lining at its base. This is shown in Figure 2.



**Figure 2. The lining and caissons on a dug well**

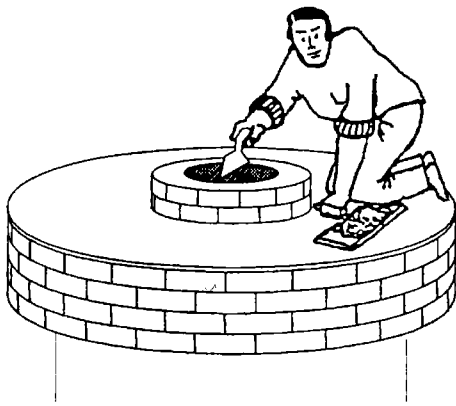
The lining should extend 30 cm above ground level to prevent surface water from seeping into the well. The headwall, or wellhead, is often made wider than the lining and supports the cover slab. Figure 3 shows how to build the headwall. Figure 3. Building the headwall

---

### **The apron and drainage channel**

The wellhead should be surrounded by a reinforced concrete apron with a drainage channel. The drainage channel allows spilt or surplus water to be directed to a watercourse, soakaway or irrigation channel to avoid creating a muddy surrounding.

Sometimes the apron is laid before the wellhead is built, and is cast as soon as lining is finished ; sometimes it is laid after the wellhead is built. Either method can be used, but it is important that the join between the wellhead and apron is watertight. Figure 4 shows how to lay the apron.



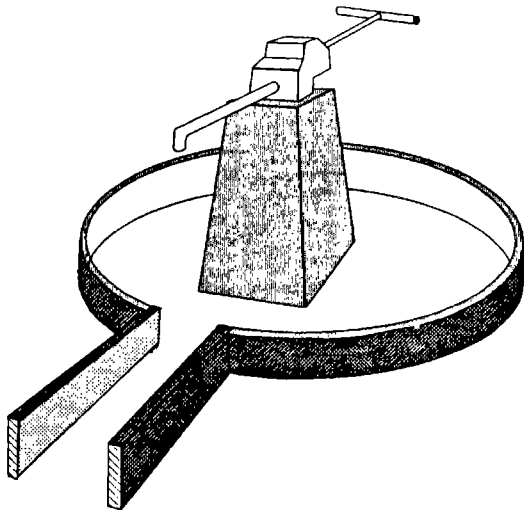
---

**Figure 4. Laying the apron and drainage channel**

---

### **Improving a well using well rings**

Where there is doubt about the stability of the well shaft, an alternative method of strengthening the shaft is to cast well rings, or caissons, and to build them up in a column to the surface, as shown in Figure 5. This has the advantage that the well can be easily re-deepened at the same time. The top of the well ring column should protrude 30 cm above the ground level to provide a wellhead.



---

**Figure 5. Improving a well using caissons**

Sinking a well ring column correctly requires experience, and the casting of well rings can be expensive. Well rings made from reinforced concrete are strongest, but they can also be made using bricks, masonry or concrete blocks. These are often fitted on top of a reinforced cutting ring or shoe. Timber cutting rings and temporary timber well rings, later replaced with brick well rings, can also be used.

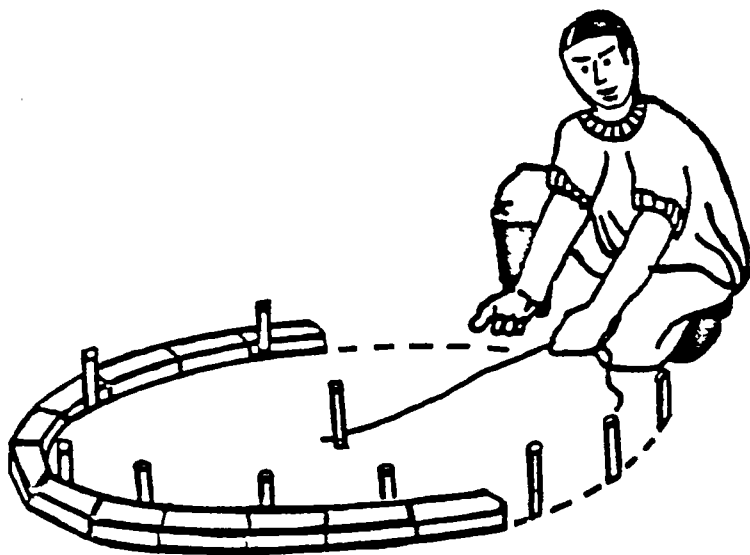
The gap between the well rings and the well shaft should be filled with gravel in the bottom half of the well. This will act as an extra filter for water entering the well. In the top half of the well the gap should be filled with an impermeable material, such as puddled clay. A drainage apron and cover slab should be cast to protect the well.

---

### Cover slab

When the lining has been completed it is important to cover and protect the well from contamination. A concrete slab with a hole in the centre to draw water, either using a bucket or a handpump, should be made as described below :

- Mark out the slab on the ground with bricks so that it is big enough to cover the well lining. Line the marked area with plastic sheet or cement bags. Reinforce the cover slab with a grid made of 6-9 mm reinforcing steel rod, set about 100 mm apart, leaving a hole for the bucket or handpump to pass through (see Figure 6).

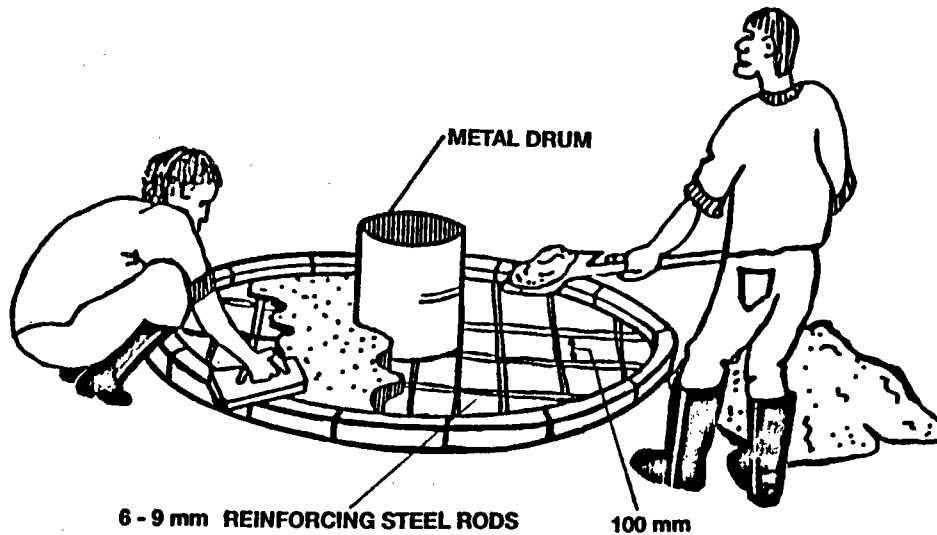


---

**Figure 6. Marking out the well cover**



- Place an old metal drum in the hole in the wire grid. Make sure that the bucket that will be used to draw water from the well fits into the drum (see Figure 7).



**Figure 7. Making the well cover**

- Make a cement mix of 1 shovelful of cement, 2 shovelfuls of sand and 3 shovelfuls of gravel, keeping the shovelfuls as equal as possible. Add just enough water to make the mixture damp, mix well and pour into the well cover mould until it is about 5 cm thick. If the mixture is too wet the strength of the concrete will be reduced.
- Remove the metal drum after about 3 hours when the cement is beginning to get hard. Then cover the slab with cement bags, cloths or grass and keep it damp for 5 days while the cement approaches full strength. Remove the cover after 5 days. The cover can then be cemented in place over the well lining.

### **Brick collar**

It is important to build a brick collar around the hole in the centre of the cover to stop spilt water running back into the well (see Figure 8). The collar should be made smooth with cement mortar. Where a handpump is to be installed it is wiser to make the collar from concrete so that it is strong enough to support the pump during use.

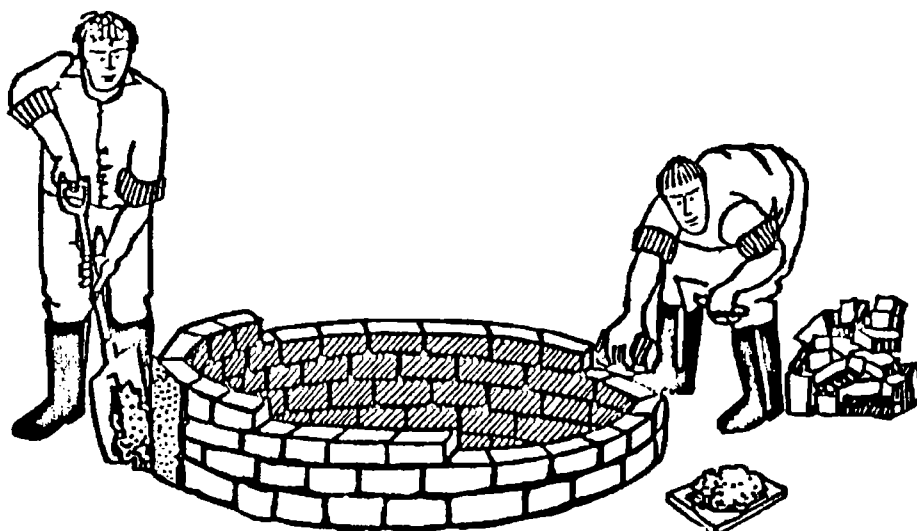


Figure 8. Making a brick collar

### Lid and water lifting

A wooden or metal lid should be made for the collar, to close the well when it is not in use. A windlass with a bucket and rope can be built and used to draw water safely and hygienically from the well (see Figure 9). The water lifting device should be carefully planned in advance, so that if necessary it can be incorporated when casting the cover slab.

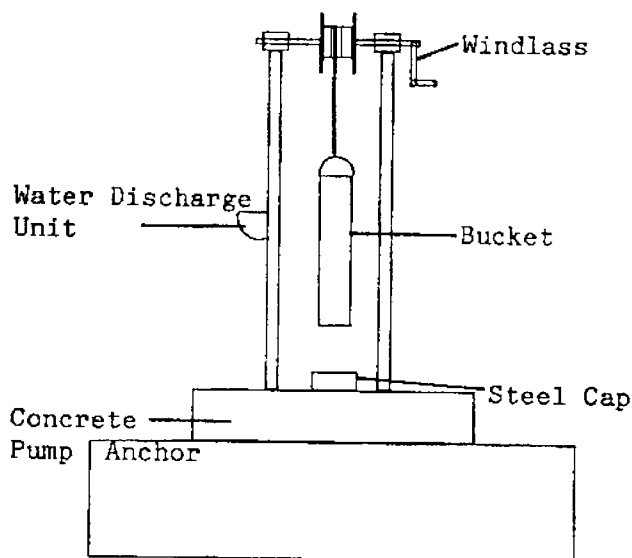


Figure 9. Lid and windlass<sup>1</sup>

If a pump is to be installed, the base bolts of the pump should also be cast into the collar slab. Care must be taken to ensure that these are vertical and of equal height. When the pump is installed it can be tightened directly onto the collar, making sure that the base lies flush in the collar. A handpump on a dug well is shown in Figure 10.

<sup>1</sup> After Morgan P. *Rural water supplies and sanitation*. Macmillan Education, Hong Kong, 1990.

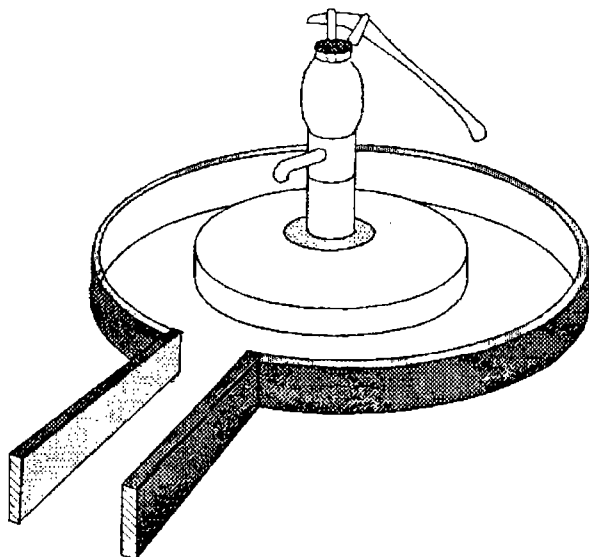


Figure 10. Handpump on a dug well

---

### *Protective fence for watering animals*

If there are animals in the area, it is a good idea to build a fence to keep them away from the well. In some areas it is common for people to take their animals to the well to drink. This means that the animals leave excreta close to the well and can damage the apron or well cover. If animals are watered at the well, it is good practice to provide a trough outside the fence and several metres away from the well for animals to drink from.

---

### *Care of the well*

Looking after the well to ensure that the community drink clean water will not take a lot of time, always follow these rules :

- Keep the bucket clean.
- Hang the bucket on the windlass.
- Keep the lid in place.
- Keep the apron and drainage channel clean.
- Always use the same bucket in the well.
- Keep the rope wrapped around the windlass.
- Only one person at a time should use the well.
- The fence should be kept in good repair to keep animals away.
- Washing should be done away from the well.

The well should be inspected regularly and any necessary repairs carried out immediately. This is particularly important if a handpump is fitted to the well. It is important to keep a stock of spares in the community, and for one or two people to be trained in pump repairs for each pump installed.

---

## *Disinfection of wells*

Before a new or upgraded well is used, it is very important to disinfect the well thoroughly with chlorine solution (see Fact Sheet 2.25).

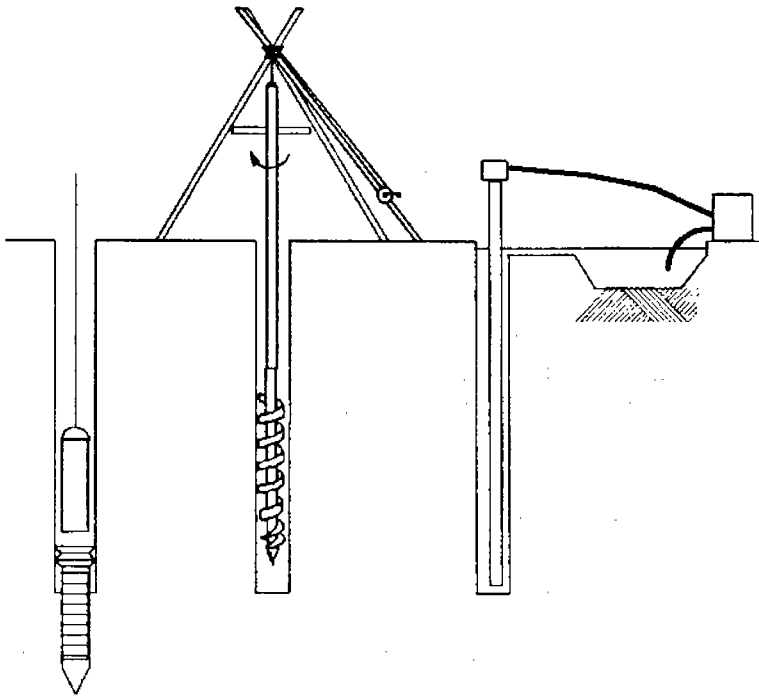
## Boreholes and tubewells

The traditional methods of drawing water from the ground, such as dug wells, have been replaced in many countries by small-diameter wells which are easier and quicker to sink and can be closed off when they are no longer needed, for instance when a refugee camp is closed. This type of well is usually fitted with a handpump to draw water to the surface, but water can also be raised using a small bucket or an electrical pump.

Boreholes and tubewells should, if possible, be sunk in the dry season and should extend some way below the water table to ensure a continuous supply of water. Water enters through holes or slots in the part of the pipe under the water table, called the well screen.

The tubewell is the cheapest to sink. The three types of tubewell illustrated in Figure 1 can all be sunk by hand :

- *Driven tubewell* made by hammering a metal pipe with a pointed end into the ground. Once the point reaches the ground water, water enters the pipe through small holes in the wall of the point and can then be pumped up to the surface.
- *Bored tubewell* made by drilling down to the water table using an auger (a special cutting tool).
- *Jetted tubewell* made by forcing water through a pipe into a hole. The water flows back up to the surface carrying soil from the bottom of the hole and making it deeper.



**Figure 1. Methods of sinking a tubewell**

Boreholes and deep tubewells need a drilling rig which may be mounted on the back of a truck or a trailer. Large drilling rigs can drill boreholes over 200 metres deep. Handpumps, however, can only be used where the water table is less than 60 metres deep ; boreholes which are deeper than this will require a motor pump. Boreholes are expensive because of the equipment needed.

It is not within the scope of this Fact Sheet to cover well sinking or drilling techniques in detail. In both cases, trained staff are required to operate the drilling rigs and install the pumps.

## *Sanitary inspections of boreholes and tubewells*

Boreholes and tubewells require regular monitoring to ensure that an adequate and safe water supply is maintained. A suggested frequency of sanitary inspections is four times a year conducted by the community and at least once a year by an external surveillance agency (see Fact Sheet 2.1).

Where a well serves a community, water quality testing should be done twice a year, once in the dry season and once in the wet season. Where there are many household wells, the surveillance agency should only test a few of the wells in a community each year. The wells selected should be generally representative of wells in the community, thus wells in locations where there are several wells nearby should be selected. The results of the water quality analysis of the wells will show whether there is contamination, and the results of the sanitary inspections will enable the causes of contamination to be identified and eliminated.

The key observations to make in a sanitary inspection of tubewells and boreholes equipped with handpumps are shown in Figure 2. The points to check in a sanitary inspection of deep boreholes where water is abstracted using a motor pump are shown in Figure 3.

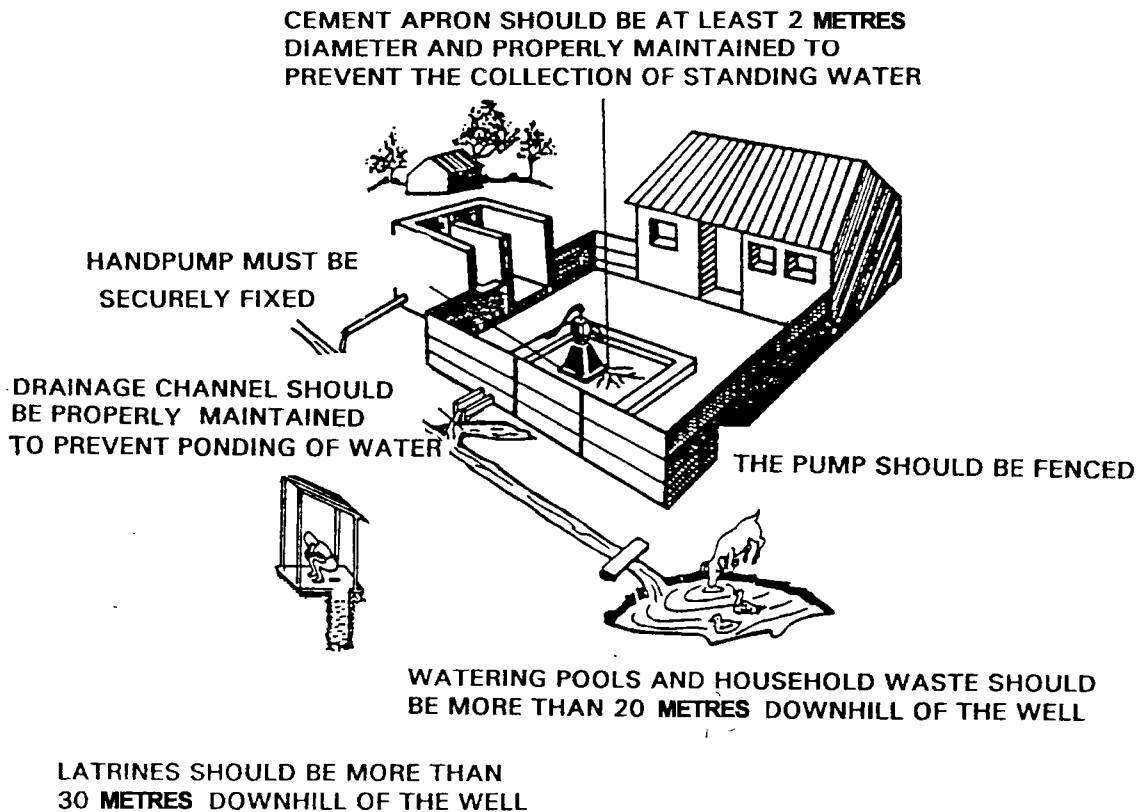


Figure 2. Sanitary inspection of a borehole or tubewell equipped with a handpump

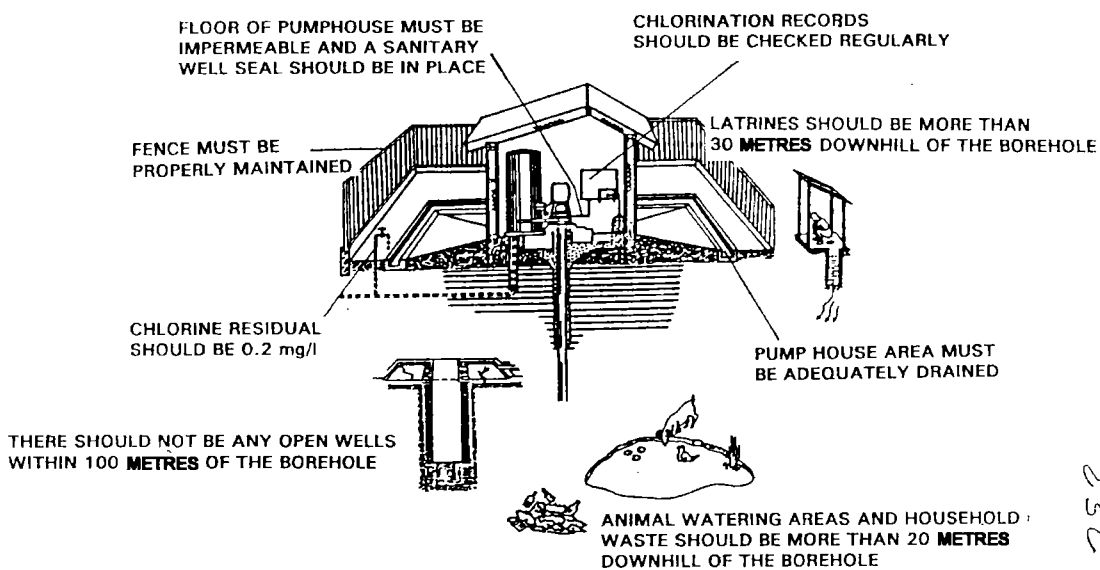


Figure 3. Sanitary inspection of a borehole with a motor pump

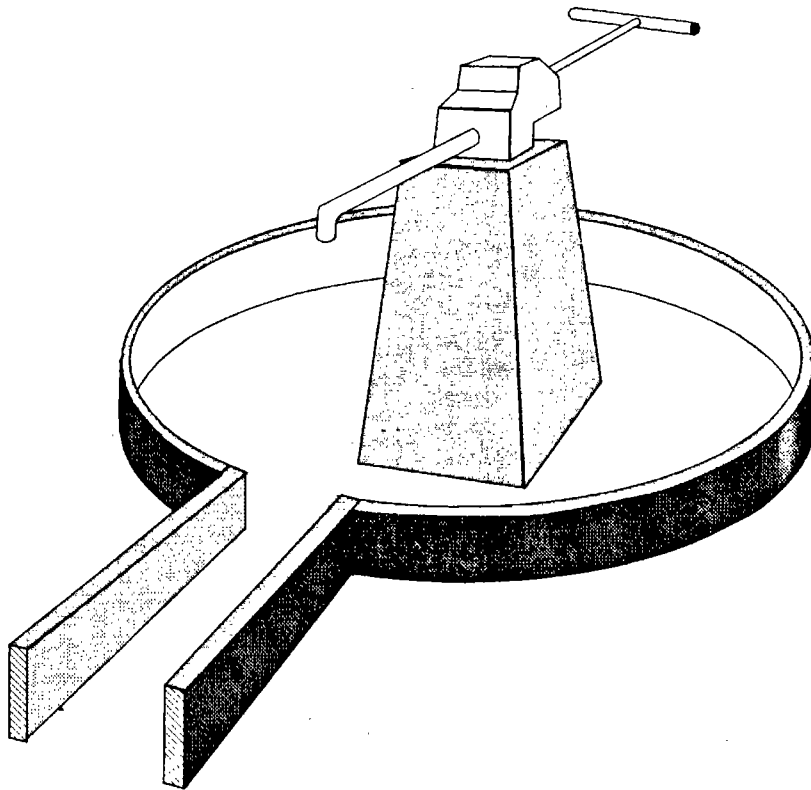
230

---

## *Operation and maintenance of boreholes and tubewells*

It is important that boreholes and tubewells are well maintained and used properly to ensure they remain fully functional throughout their full life span.

The top of the well should be completely covered to prevent any surface or spilt water from entering the well. This may be done by making a concrete plinth on which a handpump is securely fixed. It is important that the pump is fixed flush with the top of the plinth so no water can leak back into the well. Figure 4 shows a wellhead with a handpump.

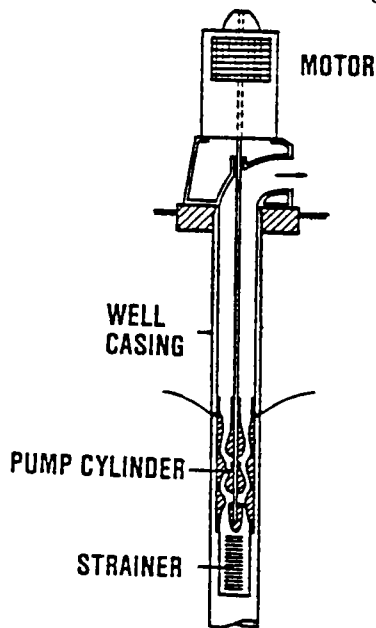


---

**Figure 4. Handpump fixed on a plinth**

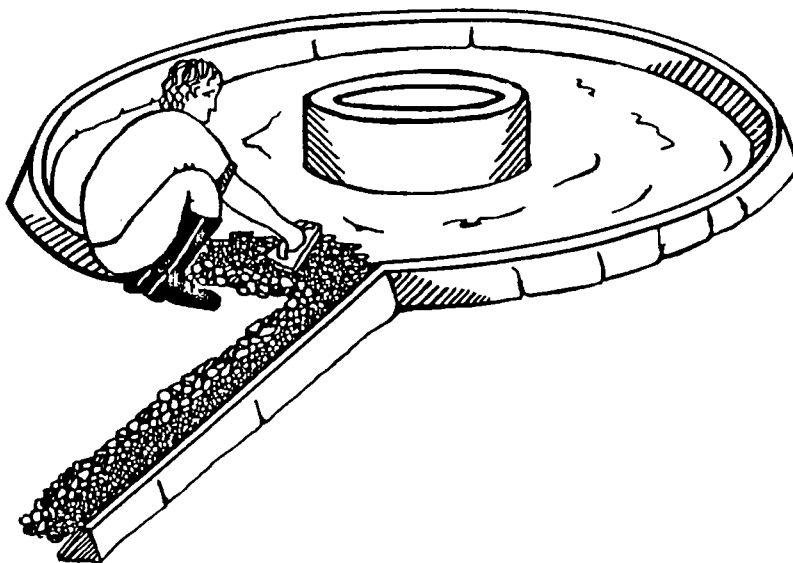


Where an electric submersible or motor pump is used, a small plinth should be made to seal the well and the casing raised to top of the plinth, as shown in Figure 5.



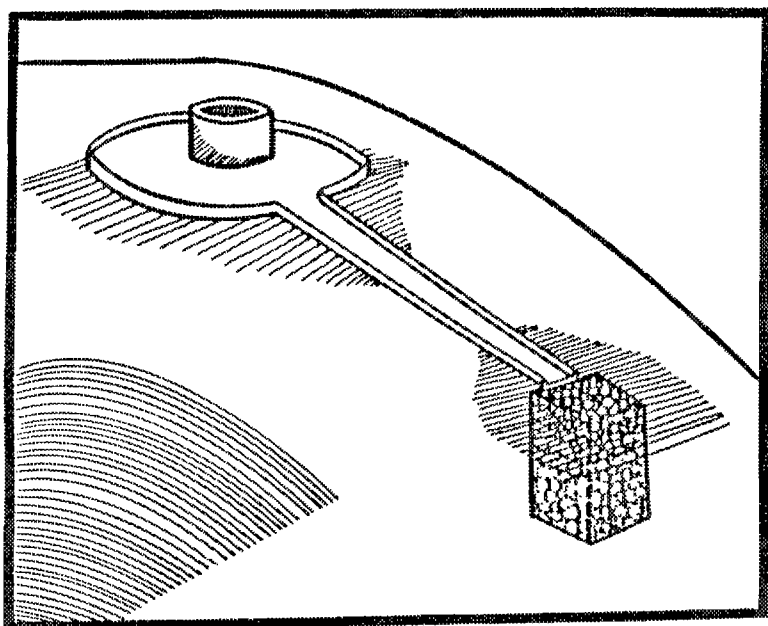
**Figure 5. Wellhead with shaft-driven turbine pump**

The plinth should be surrounded by an apron and a drainage channel built to allow spilt water to flow away from the wellhead to a soakaway (see Figure 6). The apron should be at least 3 m in diameter and made from reinforced concrete to prevent cracking. Any cracks will allow water to seep into the well. The edges of the apron should be built up to prevent pools of water forming outside the apron. The apron should be constructed so that it slopes towards the drainage channel.



**Figure 6. Making the drainage channel and apron**

The drainage channel must be long enough to take the spilt water well away from the wellhead and should flow to a soakaway (see Figure 7). The area around the soakaway pit should be planted with trees, sugar cane or other plants which absorb large quantities of water.



**Figure 7. Soakaway**

It is important that the plinth, apron and drainage channel are always kept clean, and that no pools of water are allowed to form around the well area. If any cracks appear on the plinth, apron or channel, these should be immediately repaired with mortar to prevent any contamination of the well. The drainage channel should be kept clear of any debris, otherwise the flow of spilt water may be obstructed and pools form which may lead to mosquito breeding.

---

## *Pumps for tubewells and boreholes*

Tubewells and boreholes are much narrower than dug wells and it is impossible to draw water with a conventional bucket. Water must therefore be drawn from boreholes and tubewells using a pump. It is important that pumps are well maintained and kept in good working order because, unlike dug wells, should the pump break down there is no other means to raise water from the well. At least one member of the community served by the well should be trained in basic pump maintenance and repair. Tools and spares should be available to the community and a regular maintenance schedule established, paying particular attention to the replacement of washers, seals and valves.

Various types of pump can be used to bring water to the surface. In rural areas it is normally not possible to use electrical pumps as they are expensive to buy and run. Solar power can be used to run electrical pumps in isolated areas, but the initial cost is very high. Handpumps are the most popular type of pump for tube wells and boreholes as they are relatively cheap and easy to maintain.

---

## *Protective fence and watering animals*

If there are animals in the area, it is a good idea to build a fence to keep them away from the tubewell. The fence must be well maintained and any breaks repaired immediately to prevent animals from entering the well area. Also, in the dry season it is common for people to take their animals to the tubewell to drink. This means that the animals leave excreta close to the tubewell and can damage the apron. It is good practice to provide a trough outside the fence and several metres away from the well for animals to drink from.

---

## *Disinfection of wells*

Before a new or upgraded well is used, it is very important to disinfect the well thoroughly with chlorine solution (see Fact Sheet 2.25).

# Springs

Springs are places where water that has been filtered through soil and rock reappears from underground. This filtration removes the microbes from the water and spring water is therefore often safe to drink.

Sometimes rivers or streams pass underground and reappear downstream. This is especially common in areas of limestone. These can look like springs but the water has not been filtered in the same way and it is less likely that they will be safe water sources.

Water on the surface of the ground will filter down through soil and rocks until it reaches a level through which it cannot pass (an impervious layer), or reaches a level in the ground where the soil or rock is saturated with water (the water table). The water table is not a flat surface, but roughly follows the shape of the land surface above it. Groundwater will flow down slopes in the water table until the level intersects the land surface or is forced to the surface by an impervious layer.

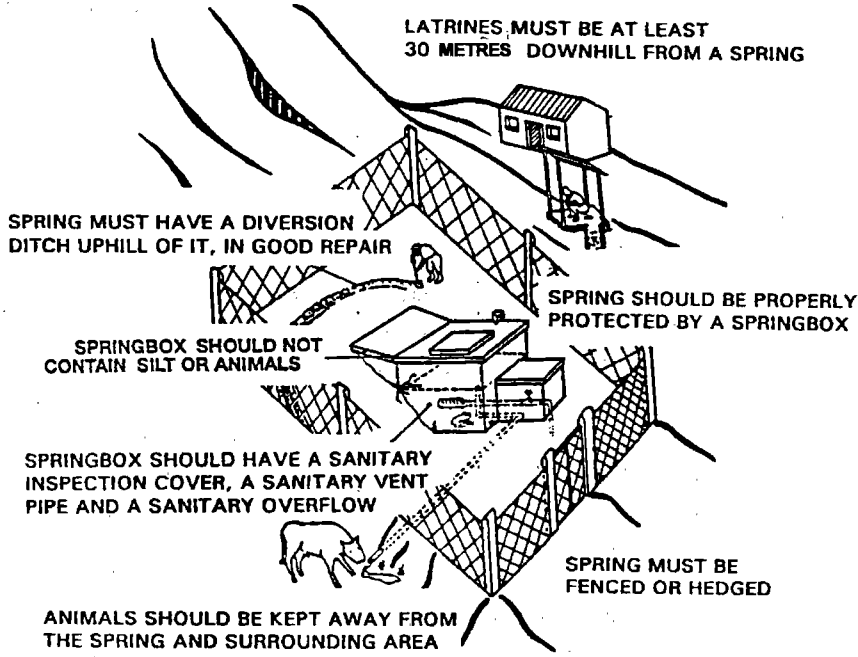
If the water becomes sandwiched between two impervious layers then enough pressure may be exerted to force water up through a hole. This is called an artesian spring.

Sanitary inspections of spring source water supplies

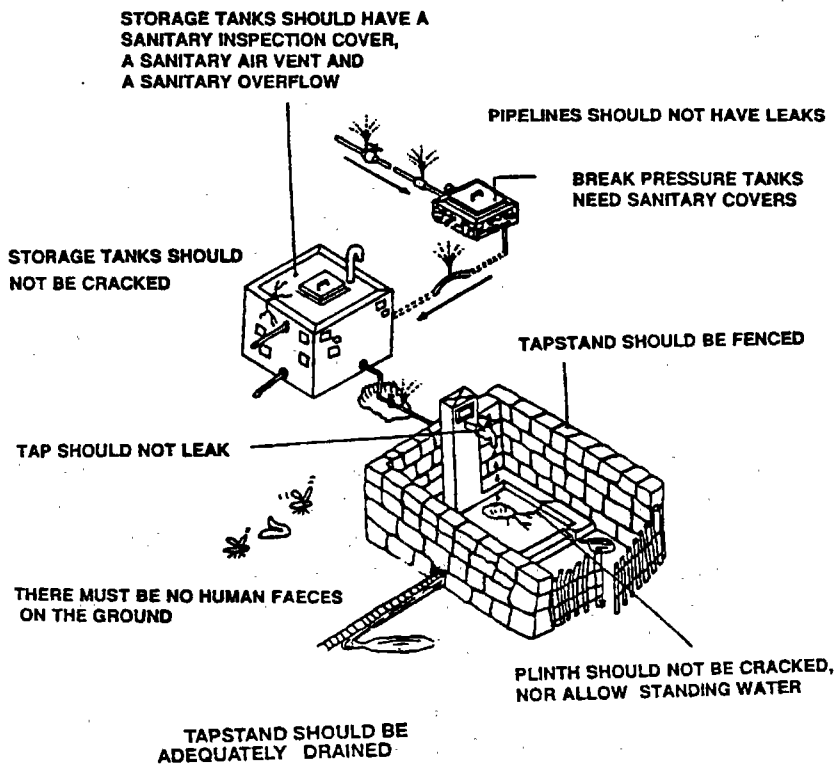
Protected spring-fed water supplies need regular monitoring to ensure an adequate and safe supply is maintained. A suggested frequency of sanitary inspections is at least twice a year conducted by the community and at least once a year by an external surveillance agency (see Fact Sheet 2.1). Sometimes the water supply agency may also conduct an annual sanitary inspection. In the inspection it is important that both the protected spring and the distribution system are checked.

Water quality testing should be carried out at least twice a year, once in the wet season and once in the dry season. The water coming from the spring and any storage tanks should be tested, and samples from outlets in the distribution system taken. In larger supplies, which serve many people, water quality tests should be undertaken more frequently and if chlorination is used residual chlorine should be analysed daily.

The key points and observations to make in a sanitary inspection of springs and distribution systems are shown in Figures 1 and 2.



**Figure 1. Sanitary inspection of a spring source**



**Figure 2. Sanitary inspection of a distribution system**

## Types of springs

There are two main types of springs : gravity springs and artesian springs.

Gravity springs occur where groundwater emerges at the surface because an impervious layer prevents it from seeping downwards, or the water table is at the same height as the land. This type of spring usually occurs on sloping ground and its flow changes with variations in the height of the water table (see Figure 3). The flow tends to vary with the time of year.

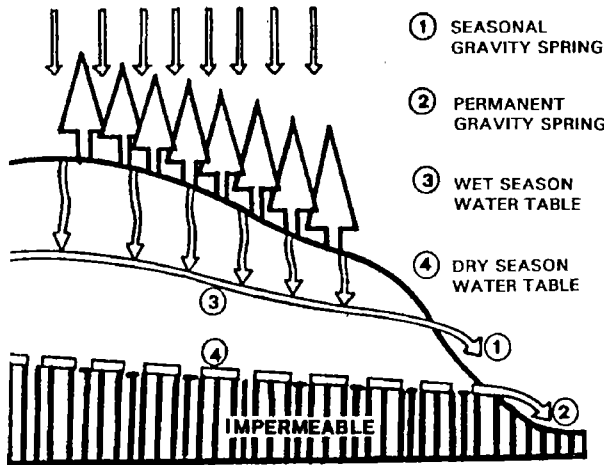


Figure 3. A gravity spring

Artesian springs occur where groundwater emerges at the surface after confinement between two impervious layers of rock. The flow is very nearly constant during the year (see Figure 4).

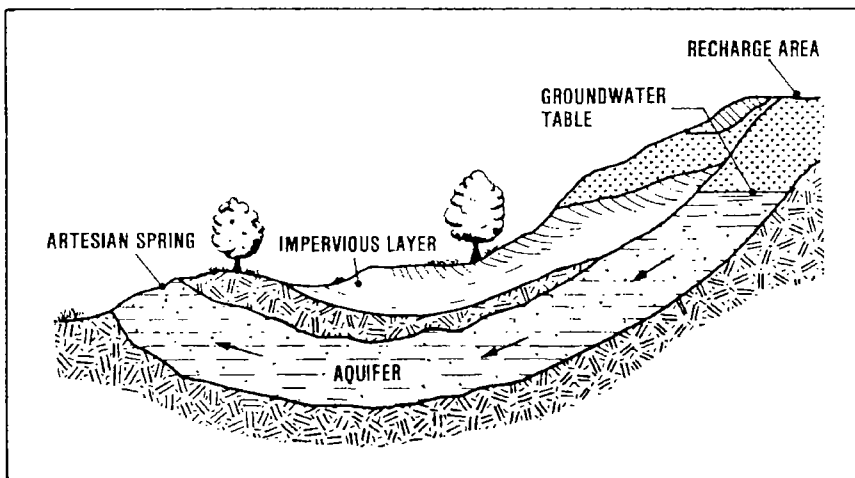


Figure 4. An artesian spring

## Why protect a spring ?

After being filtered through soil and rock, groundwater is generally free from microbes and often safe to drink. However, spring water may be rapidly contaminated when it emerges at the surface, for example by contaminated surface water nearby or by wild or domestic animals, as well as by people who collect or use the water from the spring.

## Protecting a spring

Springs are protected against contamination by construction of a spring catchment box and other protective measures.

The most important features of the spring catchment box itself are :

- The spring water does not emerge at the surface but flows directly into a covered box. The water is then collected by the consumers either directly from a pipe running from the box or from taps if the spring is connected to a distribution network.
- The box needs a lid which can be opened to enable cleaning. This should be mounted so as to prevent animals or leaves from entering, and should be kept locked.
- The space behind the box, above the eye of the spring, should be sealed with impermeable material such as puddled clay or a concrete plinth.
- The recharge area or source of water for a spring may require protection. Protection may consist of restricting land uses or ensuring proper disposal of human and animal waste in the recharge area.

Figure 5 shows a typical spring protection box.

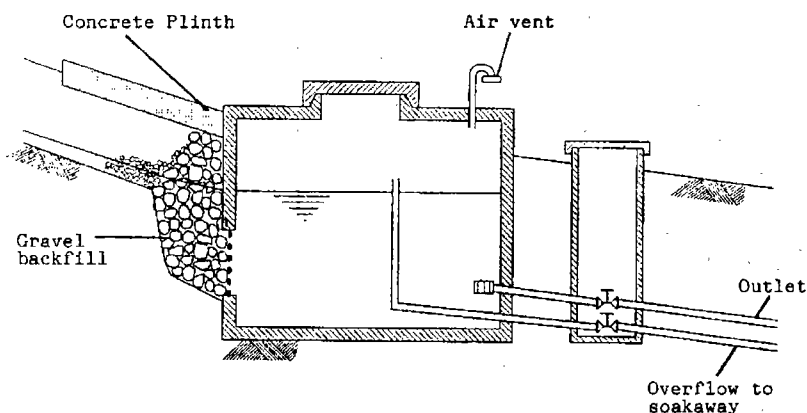


Figure 5. Spring catchment box

---

**As well as the box itself, it is also important that :**

- There are no latrines nearby (within 30 metres) or uphill of the box.
- There are no sources of severe contamination in the vicinity.
- Infants and animals should be excluded from the area of the spring, by means of a fence constructed around it.
- A surface water diversion ditch should be dug above and around the area of the spring, because water running across the surface, especially during the rainy season, may carry contamination to the spring.

Ideally the construction of a spring catchment box should be undertaken by a qualified person. The other protective measures described above may easily and rapidly be installed by persons with limited experience.

---

**Construction of a spring protection box**

The general procedure for constructing a spring protection box is described below.

---

**Excavation**

- Dig back until you can see a clear point from which the spring emerges (the eye of the spring). Do not dig down into the impervious layer. If there is more than one point then dig back further to see if they converge. If the points do not converge, then separate spring boxes will have to be constructed for each, or a seep collector with drains will have to be built.
- Dig a temporary drainage channel that will take the water away from the spring during construction, as shown in Figure 6.



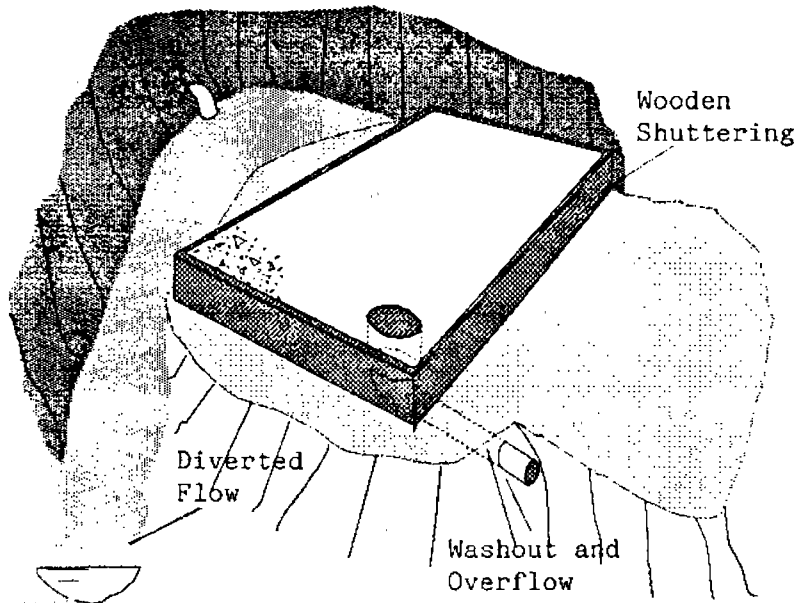


Figure 6. Drainage channel

### Concrete base

- Mark the edges of the base with wooden shuttering so that the base is close to the eye of the spring, extends at least one metre forward from the eye and across its full width (see Figure 6).
- The spring box will need both an overflow pipe and a cleaning pipe. These can be made cheaply and without valves if a female connector leading to an overflow pipe is built flush into the base. This is shown in Figure 7.

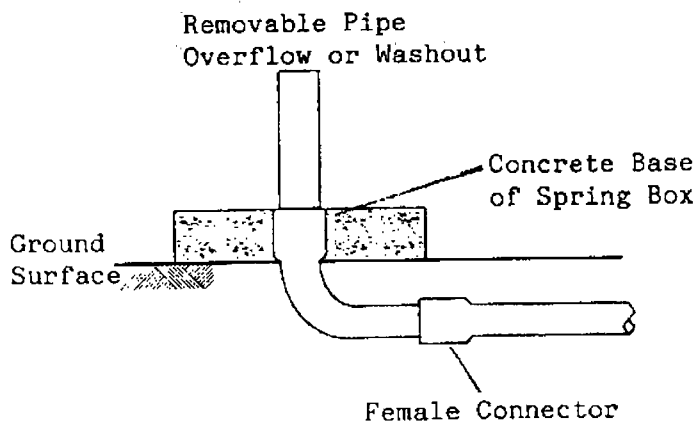
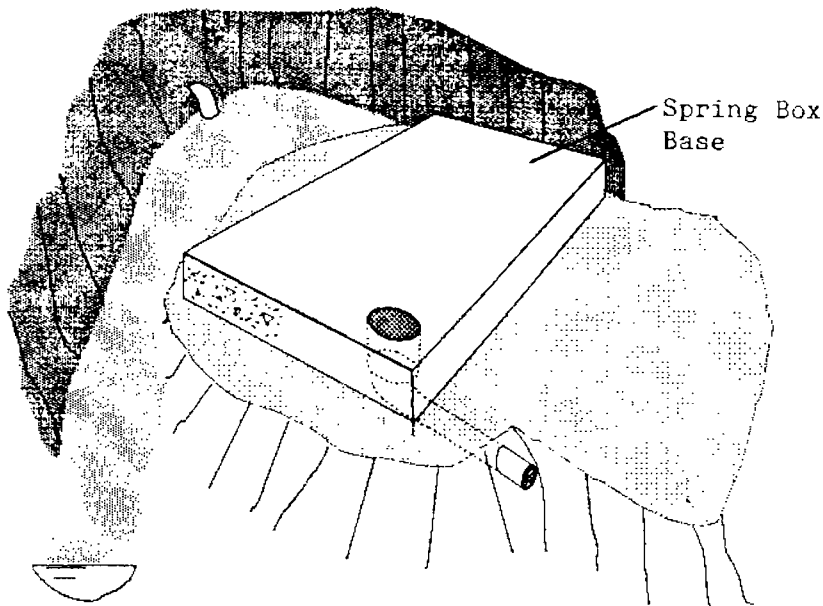


Figure 7. Overflow pipe

- Pour the concrete base from a mixture of 1 :4 :8 (cement :sand :gravel). Compact (tamp) the concrete and allow it to cure. The base is shown in Figure 8 below. Curing will need 7 days and the concrete should be kept damp all this time by covering it with old cement bags, rags, sacks or similar items. Moisten them at least once a day. When it is very hot, the sacks or bags etc will dry out quickly and should be checked and moistened, if necessary, two or three times a day.



**Figure 8. Base of the spring box**

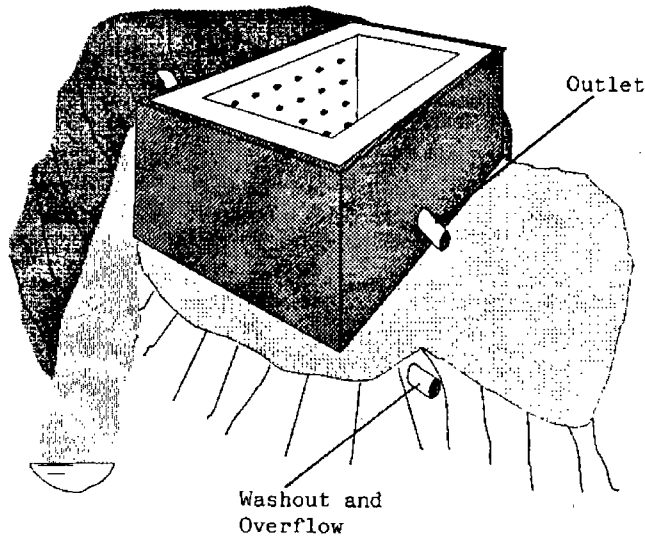
### **Build the back wall**

- The back wall is partly open so that water from the spring can get into the box. It can be a dry stone wall, a perforated concrete wall (from cast concrete with small pieces of plastic tube passing through it) or a wall made by using no-fines concrete (that is, a mixture in which no sand is used).
- The walls of the box can be made either like a mortared wall (using local stone) or by pouring a stiff mixture of 1 :2 :4 (cement :sand :gravel) into shuttering. In either case the walls should be at least 100 mm thick. Note that the minimum amount of water should be used to make the mixture cohesive - if the mixture is too wet, the strength of the dried concrete will be reduced.

If the walls of the box are made as a mortared wall then the inside of the box (except the back wall) should be made waterproof by rendering. The box need not be very large for a small spring (that is, up to one litre per second). A box of about 800 mm square is adequate.

- An outlet pipe must be incorporated into one of the walls, as shown in Figure 9. If water is to be collected directly from the spring, then this outlet pipe should be of galvanized iron and be well supported. In this case a concrete apron should be built around the spring with a kerb and drainage for spilt water.

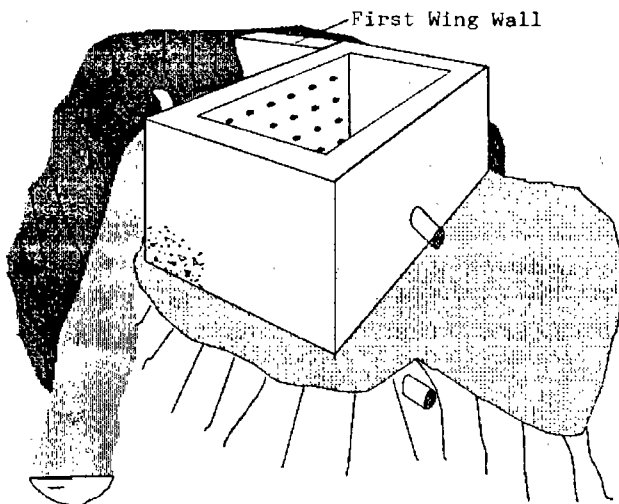
The outlet pipe should be raised slightly above the level of the spring box base. The outlet pipe should be covered with a mosquito screen on the inside.



**Figure 9. Box and outlet pipe**

### **Wing walls**

- While the spring water is diverted to one side of the box, construct a wing wall connected to the other side of the box, as shown in Figure 10. The wing wall is to ensure that all the water from the spring enters the box. The wing walls may be constructed in a similar way to the walls of the spring box.



**Figure 10. Wing wall**

- Divert the flow of the water so that it passes into the box and through the overflow pipe. Then construct the second wing wall on the other side, as shown in Figure 11.

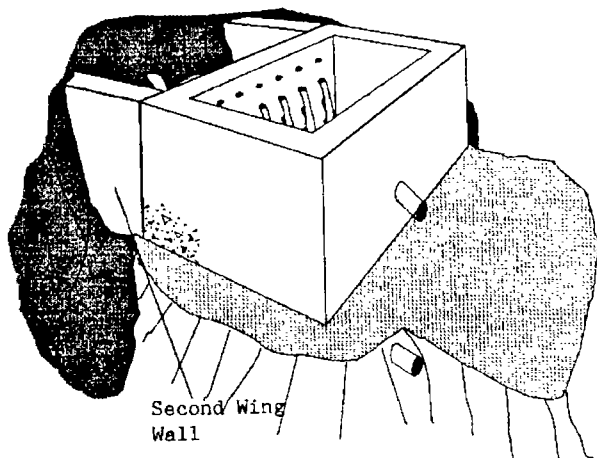


Figure 11. Second wing wall

### Finishing the construction

- The area between the eye of the spring and the back of the spring box should be filled with gravel. This gravel should then be sealed on top by pouring a concrete apron over it or by adding puddled clay. This protection should be sloped so that it carries water away from the back of the box to the sides, as shown in Figure 12.

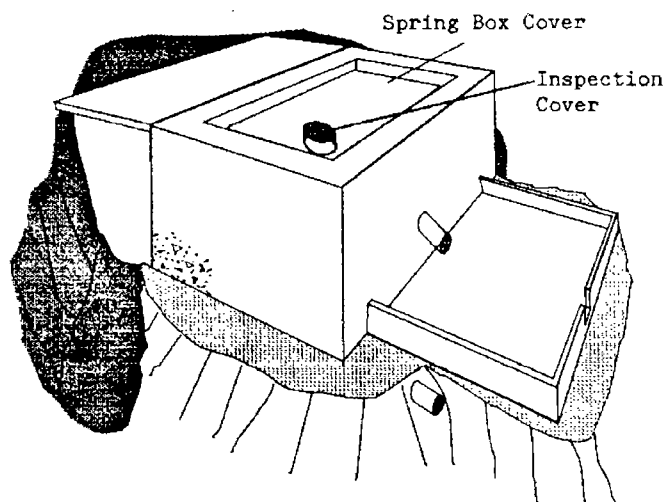


Figure 12. Finishing the box

- Cut a length of pipe to fit into the female connector incorporated into the base of the box. The top of the pipe should be at the level of the eye of the spring, no higher. Once installed it will function as an overflow and prevent water pressure back on the eye of the spring which might force the spring to divert.

---

### **Lid**

- Make a lid which has handles and overlaps down the sides of the box (a sanitary lid). This can be made of metal or reinforced concrete.

---

### **Protecting the surroundings**

- Excavate a surface water diversion ditch upstream of the spring box and about eight metres away from it.
- Build a wall or fence all around the spring area to exclude children and animals. It should be built about ten metres away from the spring box.

# Infiltration galleries

An infiltration gallery is a horizontal drain made from open jointed or perforated pipes, or a block drain, which is laid below the water table and collects groundwater. Infiltration galleries need soils that are permeable to allow sufficient water to be collected. The gallery should be surrounded with a gravel pack to improve flow towards it and to filter any large particles that might block the perforations.

Infiltration galleries can be used to collect sub-surface flow from rivers. Water is taken to a collection well, or sump, and then either withdrawn directly or pumped to a storage tank.

Galleries are often used in conjunction with other water supply systems as a means of increasing the quantity of water intake in areas of poor water yield. In this instance one or more galleries are built which drain into a central point, such as a hand-dug well or spring box. These are called collector wells. When an infiltration gallery is built, it is important to protect it from contamination by locating it uphill and the minimum safe distance from any latrines. This distance is site specific, although a figure of 30 metres has been suggested as a general guideline. The gallery should also be constructed to ensure that unfiltered surface water cannot enter.

Infiltration galleries vary in size, from a few metres feeding into a spring box, to many kilometres forming an integral part of an urban water supply.

---

## *Sanitary inspections of infiltration galleries*

Sanitary inspections of infiltration galleries follow a similar format to inspections of springs (see Fact Sheet 2.1). A suggested frequency of inspection is once a year by each group: the community, the water supply agency and an external surveillance agency. Particular attention should be paid to the catchment area of the gallery, especially with shallow galleries. The water collected in infiltration galleries has often not had as much filtration as well or spring water, thus may be more vulnerable to contamination.

Water quality testing should be done twice a year, once in the wet season and once in the dry season. The water at various points in the gallery, at the collector well or sump if present, and water in the distribution system should all be tested.

---

## *Construction of infiltration galleries*

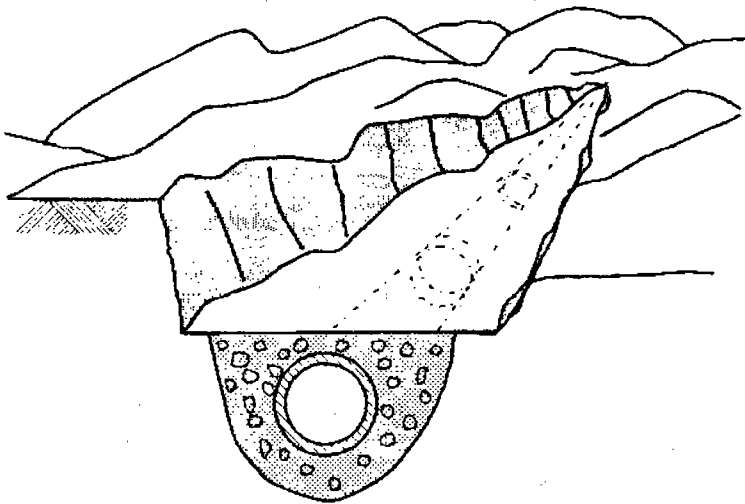
To ensure a continuous supply of water, infiltration galleries should, if possible, be built at the end of the dry season and should be at least one metre under the dry season water table. The sides of the gallery will need to be supported by props and formwork during excavation.

---

### **Infiltration galleries can be built in the following way :**

- Excavate a trench to at least one metre below the water table, supporting the sides to prevent collapse.
- Lay graded gravel on the base of the trench.
- Lay the pipe or drain blocks on top of the gravel. Cover the top and sides with more graded gravel.
- Cap the gravel with an impermeable layer of puddled clay to prevent surface water entering the gallery.

This method will require a de-watering pump whilst the drain is being laid and can be dangerous, especially where the soil banks are prone to collapse. This method is most appropriate when collector galleries are laid alongside rivers where the groundwater is close to the surface. Figure 1 shows a trench infiltration gallery.



---

**Figure 1. A trench infiltration gallery**

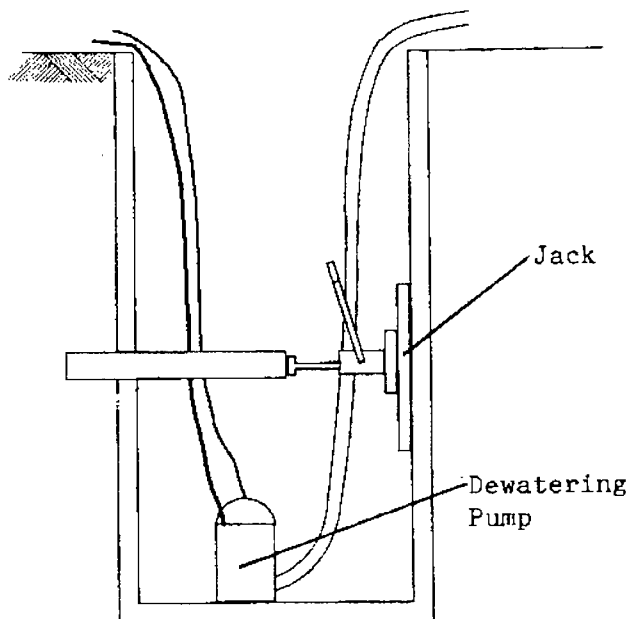
## Collector wells

### To improve the yield of a well, collector wells can be constructed as follows :

- A pipe is laid horizontally through the side of a well with a well point on the end of the pipe.

This method is used when the gallery is needed at depth to improve the yield of a dug well. It is usually not possible, however, to position a gravel pack around the gallery. Clogging of the perforations is thus more likely, and careful design is needed to avoid this difficulty. A drainage pump will be necessary to keep the well dry as the pipe is driven into the well wall.

The pipes should be driven into the well so that they slope down to the well. To ensure continuous flow, the well point should be well under the dry season water table. Collector wells are not easy to maintain and if driven off course are not easily removed or realigned. During driving, if the well point hits a rock it may break and allow soil particles to enter the gallery. A survey of the area to be driven through should therefore be made using an auger to find out if there are rocky areas. The galleries can be driven in a number of ways - by direct hammering, "jacking" or jetting. Figure 2 shows a jack driven gallery.

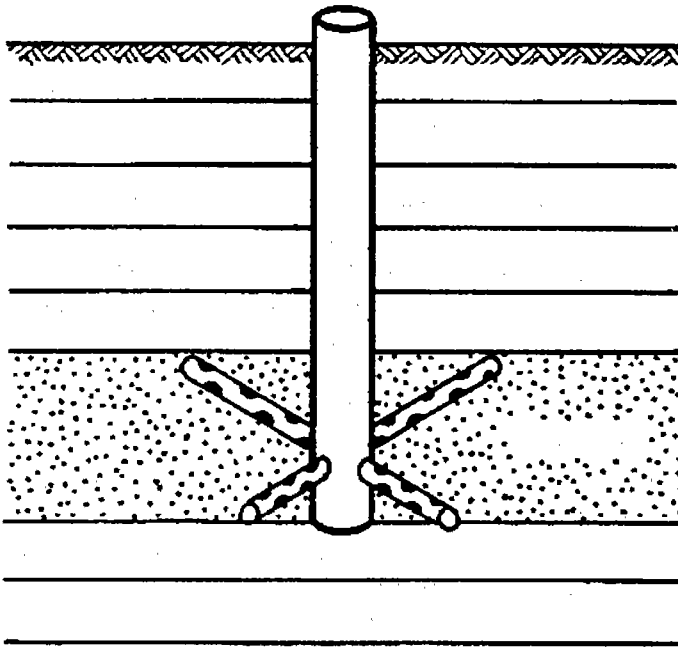


**Figure 2. An infiltration gallery driven through the side of a well**



**Fact Sheet 2.5**

Where the yield of a well is very low, several collector wells can be constructed, as shown in Figure 3.



**Figure 3. Several collector wells feeding a central dug well**

Infiltration galleries should be regularly inspected, where possible, and the perforations and joints cleared of any debris. This can be done by jetting high pressure water along the pipe or drain. Care should be taken not to damage the gravel pack by forcing water through it at too high pressure.

# Rainwater collection

Rainwater is collected and used for domestic purposes in many parts of the world. This is normally done by individual households.

Rainwater collection can be practised under a variety of conditions in both urban and rural areas. Rainwater collection has been successfully used as a short-term measure following disasters in which water supplies were disrupted or contaminated.

Rainwater collection is possible in most areas. Its practicality depends on the expectations of the users and on rainfall.

Rainwater collection systems have three major components :

- A hard impenetrable surface such as a roof or concrete slab onto which rain falls.
- A storage container. In practice, storage at household level is limited to a few thousand litres (a few cubic metres).
- A means for collecting water from the collection surface and passing it to the storage container, such as a gutter and down pipe. This should include a filter for removing any solids from the water.

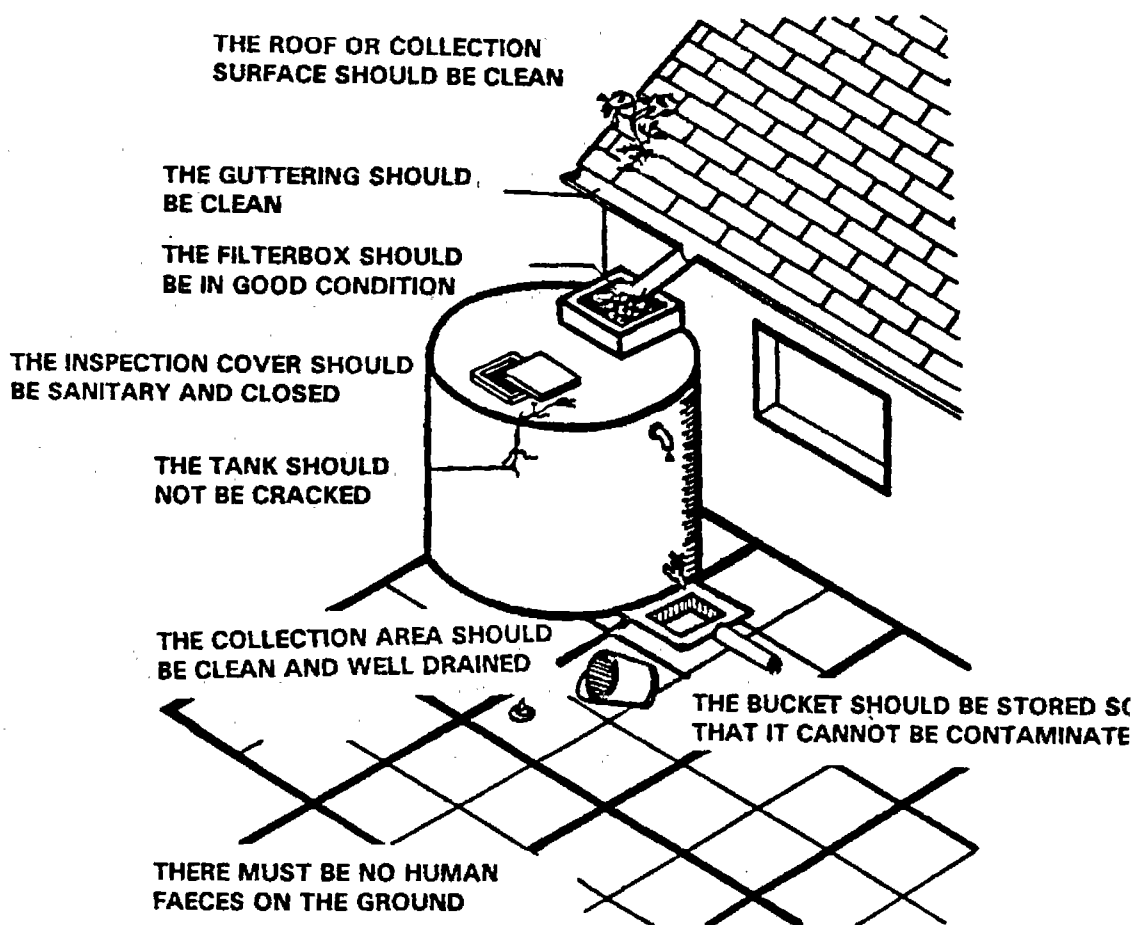
Where a suitable collecting surface already exists, rainwater collection can provide a safe, low cost source of water, or a supplement for an inadequate or contaminated public supply, at household level. On a larger scale, however, the cost of the storage tank may be prohibitive.

Rainwater that is stored for long periods of time may deteriorate in quality if bacteria are allowed to grow. Household rainwater collection systems nevertheless have the advantage that quality and storage are controlled by the users. If there are worries about water quality, it may be useful to read Fact Sheet 2.34 which describes household treatment and storage of water.

## *Sanitary inspections of rainwater collection systems*

Rainwater collection systems should be inspected regularly to ensure that an adequate and safe water supply is maintained (see Fact Sheet 2.1). A suggested frequency of inspection is at least twice a year by the household and an annual inspection by an external surveillance agency. The household should conduct a sanitary inspection during the dry season to identify any repairs that may be required, to clean any sediment and, during the wet season, to check that the collection system is functioning correctly. Where rainwater is collected by households, a surveillance agency should carry out a water quality analysis of some of the tanks in a community. If different collection surfaces or materials are used, then samples should be taken from each type. Where rainwater collection is used to supply a community, water quality tests will be required once, preferably twice, a year.

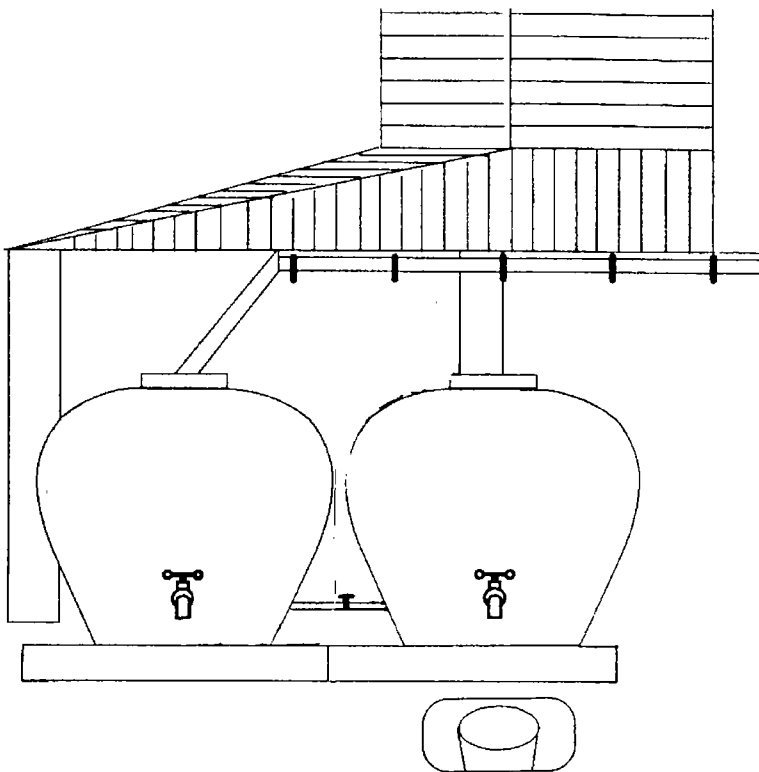
The key points and observations to be made when conducting a sanitary inspection of a rainwater collection system are summarized in Figure 1.



**Figure 1. Aspects of a rainwater collection system to be checked during a sanitary inspection**

## Collection surfaces

The simplest form of rainwater collection is from roofs. This can be done using traditional roofing materials such as thatch (although discolouration of water will occur), improved local materials such as fibre-cement tiles or materials such as corrugated iron sheeting. Guttering for carrying water down the collection surface to the storage tank may be adapted using traditional materials, such as split bamboo, or modern plastic gutters. Improvements in roofing and guttering for rainwater collection may be linked to general housing improvement programmes, for example in peri-urban areas and poor rural areas. Figure 2 shows one method for roof collection of rainwater with connected tanks for increased rainwater storage.

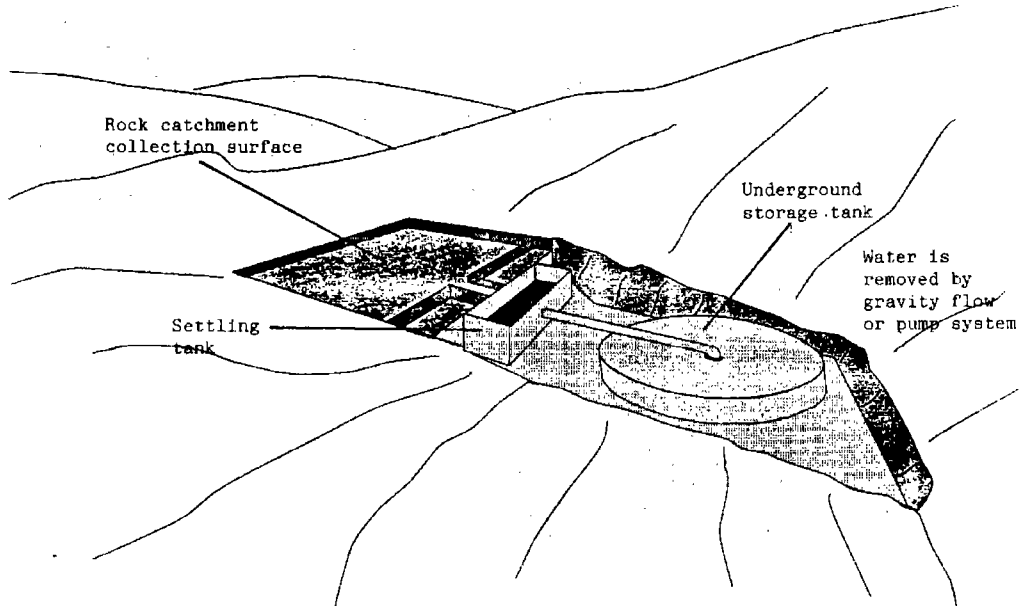


**Figure 2. Connected tanks for increased rainwater storage**

Collection of rainwater at ground level is often used on a large scale to store water for irrigation during the dry season. This Fact Sheet only covers ground collection of rainwater on a small scale for domestic use.

Some households in rural areas have a threshing area or grain drying area, which is used only during harvest time when there is little or no rainfall. This area can be used to collect rainwater during the wet season, which can be stored in an tank. It is important that the tank has watertight cement-plaster walls, a strong raised sanitary cover, and a trap to stop dirt and solids entering the tank.

Figure 3 shows a rock catchment system. Rainwater runoff is collected in a natural catchment basin from the surrounding bare rock. The water is directed from the catchment floor into a silt trap, and then into a sealed tank. The water may be drawn off by gravity-feed downhill, or by a pump.



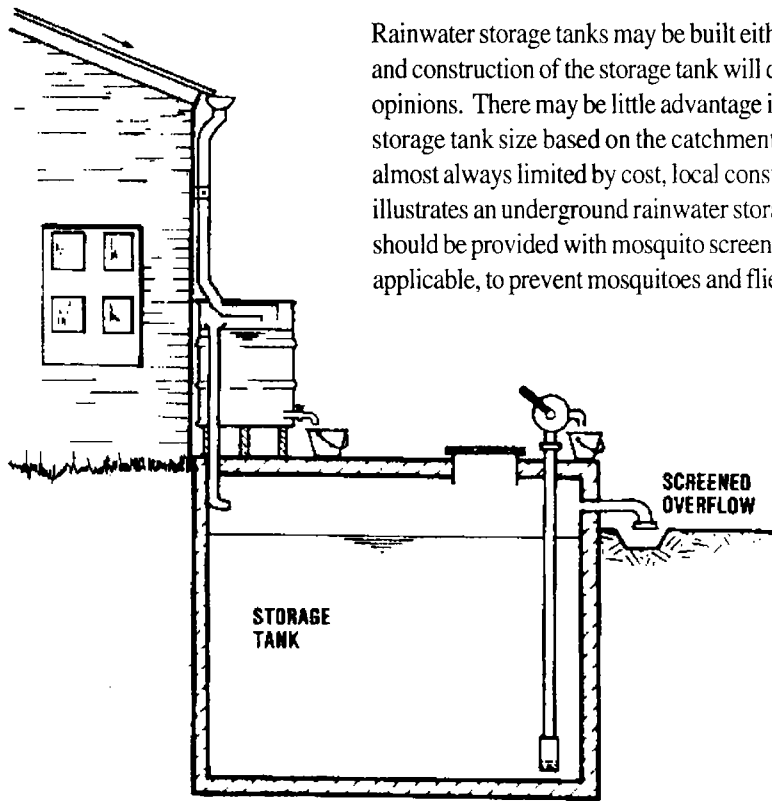
**Figure 3. Rock catchment system with underground rainwater storage tank**

The collection surface may be made of a variety of materials. The following table summarizes the efficiency of different materials.

*Collection materials*

<b>Type of material</b>	<b>Efficiency</b>
Concrete	Very Good
Plastic sheet (ground covered)	Good
Butyl rubber	Good
Brick	Fair
Compacted, smooth soil	Fair
Clay/cow-dung threshing floors	Fair
Uncompacted soil	Poor

## Storage



Rainwater storage tanks may be built either above or below ground. The size and construction of the storage tank will depend on local materials, skills and opinions. There may be little advantage in making detailed calculations for storage tank size based on the catchment area, rainfall and water use, as size is almost always limited by cost, local construction skills and materials. Figure 4 illustrates an underground rainwater storage tank. A rainwater storage tank, should be provided with mosquito screens fitted to the tank openings, where applicable, to prevent mosquitoes and flies from breeding in the tank.

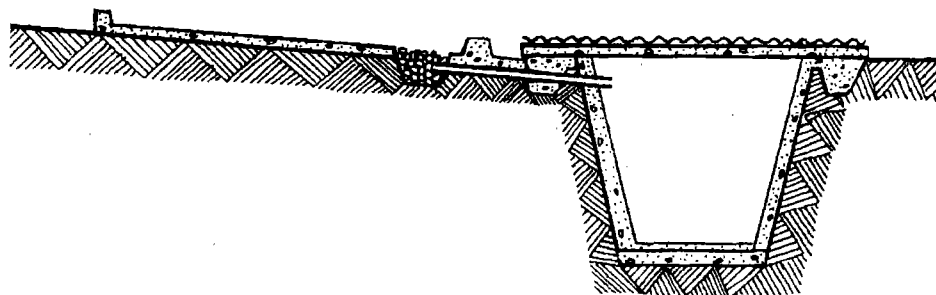
**Figure 4. Rainwater storage tank**

It may not be cost effective to build a tank large enough to store water for the whole dry season. If a storage tank can provide water for the first weeks of the dry season when the household is busy with crop harvesting, it will make time consuming trips to local springs or wells unnecessary at least for this period.

Where the cost of individual household rainwater storage tanks is too high for local people, communal tanks may be built between several households or for a large public building such as a school. Local opinions are very important with regard to communal systems, and cleaning and maintenance responsibilities need to be clearly defined.

## *Need for a silt trap and foul-flush diversion*

A means for diverting the first flush of water from the collecting surfaces and for separating solids should be incorporated into the system. The main reason for this is not to stop germs getting into the storage tank, but to keep dirt and other solid material out of the tank where it may give an unpleasant taste to the water. A simple trap, or coarse filter, is usually sufficient. Figure 5 shows a trench filled with rocks, which acts as a silt trap. This will remove the debris picked up from the collection area before the water enters the storage tank. The silt trap must be cleaned regularly to reduce contamination of the water.



**Figure 5. A simple silt trap**

During the first few storms of the year and at the end of the rainy season as storms become less frequent, the first water that comes from the collection surface should be diverted from the tank because this water will carry dirt from the collection surface. This can be done either by using a swivel joint on the inflow pipe or by disconnecting the inflow pipe from the tank. It is a good idea to divert the first water even if a silt trap is built, as otherwise the trap may block quickly and overflow. Once the storms become more frequent, it is not necessary to divert the first flush away from the tank if the tank has a silt trap, as the amount of dirt brought from the collection surface will decrease.

---

### *Planning a rainwater collection system*

When planning a rainwater collection system, it is important to assess both social and technical aspects. Social aspects include asking people about the following :

- How many local people collect rainwater, and by which methods ?
- What is the local opinion about rainwater quality and its use ?
- What is the local feeling with respect to individual or shared storage tanks ?
- How much time and money do local people wish to spend on rainwater collection as a water source ?
- What is the best time of the year to start a rainwater collection construction programme ? This is not, say, at harvest or planting time when people in rural areas are busy.

---

**Technical aspects include :**

- Obtaining official records of local rainfall, where possible.
- Asking local people about local rainfall and folklore about droughts and suchlike.
- Quality of available materials for catchment and guttering.

---

*Operation and maintenance*

Rainwater collection systems must be properly maintained if the water quality is to be acceptable. The following table summarizes the tasks which should be undertaken.



## Surface water abstraction

Surface water supplies are those which use rivers, lakes or ponds as their source. Surface water often needs treatment before it is delivered to the user, as it may be contaminated by faecal and organic material and may carry a large silt load.

Surface water is often used for large urban water supply systems, as rivers and lakes can supply a large, regular volume of water. For small community supplies, other forms of water supply, such as wells or spring fed gravity systems, are generally preferred to surface water. This is because the cost of treatment and delivery of surface water is likely to be high, and operation and maintenance less reliable.

There are a number of ways of abstracting surface water. Water may have to be pumped or piped from the intake structure to a treatment plant or storage tank unless the intake is at a higher elevation than the plant or tank.

---

### *Rivers*

In many countries rivers and streams have a wide seasonal variation in flow, and this affects water quality. In wet periods, water may carry a very high silt load. There is a high risk of faecal contamination in wet periods, particularly at the start, as faeces are washed into the river. As the flow increases, however, the wastewater will be diluted and the risk to health should decrease. In dry periods, the silt load will be lower but the dissolved solids much more concentrated.

River water can be drawn off either directly from the river or by tapping into sub-surface water near to rivers.

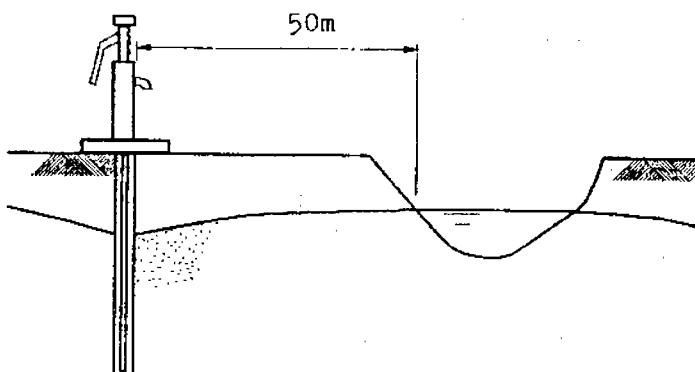
---

### *Abstraction of sub-surface water*

The cheapest and, for small supplies, the most appropriate way to abstract river water is to sink a well near to the river to tap the sub-surface flow. This requires sufficient permeable material, such as gravel, between the river and the well site. It has the advantage that the water is filtered through the bank material and may not require further treatment. Wells of this type should usually be situated approximately 50 m from the river to ensure that the water has been well filtered.

The wells can be dug by hand, drilled, jetted or augered, and should be extended some way below the river bed to ensure a continuous supply of water. The top of the well should be above the flood level of the river and sealed to

prevent surface floodwater from entering the well. A lifting mechanism, such as a handpump or rope and bucket, will be needed to take the water from the well. Figure 1 shows a river bank well.



**Figure 1. A river bank well**

An alternative method of river water abstraction which also relies on the collection of sub-surface flow is the construction of infiltration galleries, (described in Fact Sheet 2.5).

An infiltration gallery is an open jointed or perforated drain pipe which is laid below the level of the river bed to collect water. An infiltration gallery can be constructed by digging a trench and laying a pipe alongside a river. The water flows along the drain into a collection chamber or sump, from which it is withdrawn by a pump or bucket, or pumped into a distribution network. The drain should be surrounded by gravel to increase the flow and prevent blockage of the pipe by fine material. This method is most appropriate in river beds of medium to coarse sand, where there is no sediment accumulation.

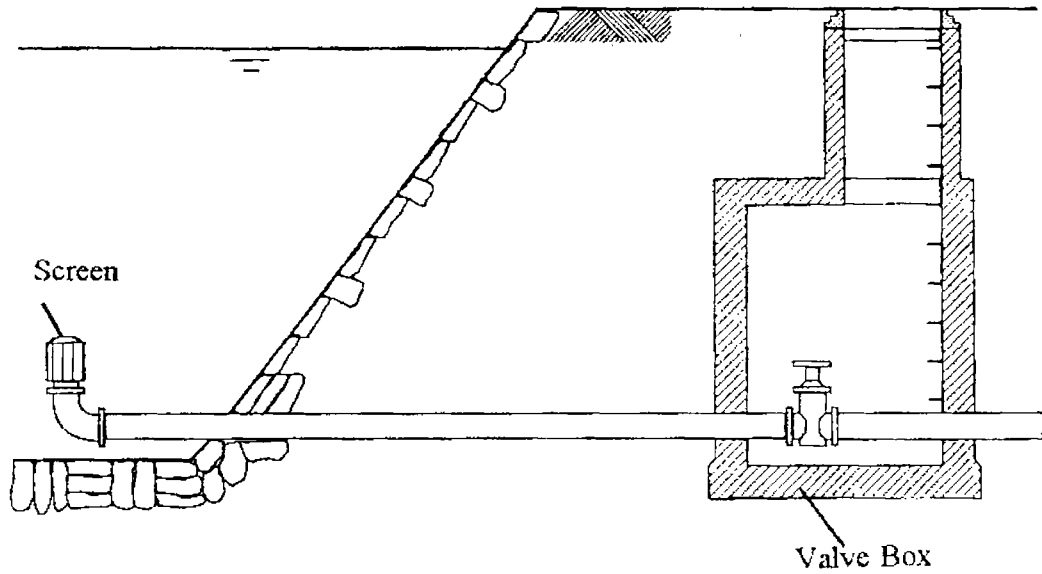
---

## *Direct abstraction of river water*

In some areas, water is taken directly from a river into the water supply system. When mountain streams are tapped well above permanent human habitation, the water may only require filtration and terminal disinfection before it is used. When water is abstracted from rivers where there is permanent human habitation or activity upstream, the water must be treated before it is used. ***If this water is not treated it represents a major health risk to the users.***

Direct intakes from rivers require a minimum depth of water all year round to ensure a permanent water supply. A weir may have to be constructed downstream of the intake to ensure that a sufficient depth of water is available.

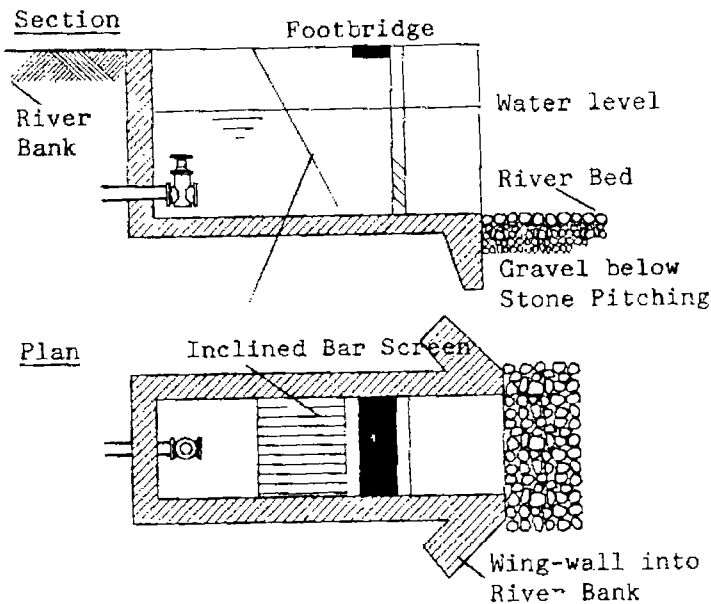
Where a river transports no boulders or rolling stones that would damage the intake, an unprotected intake may be adequate. An example is shown in Figure 2.



**Figure 2. An unprotected river intake**

Most rivers will, however, transport large material sometimes, even if only during occasional floods. It is therefore a good idea to provide some protection for the intake.

An intake may be protected as shown in Figure 3. In this case the water is abstracted through an intake built into the river bank. The intake is protected by wing walls extending from the bank and large stone pitching against floods and scour.



**Figure 3. A protected river intake**

Screens are used to prevent debris and large stones from entering the intake. The screen consists of a row of 25 mm bars inclined at 60 - 75 degrees to the horizontal and spaced about 100 mm apart. The bars are sized to ensure that the velocity of the water entering the intake is about 0.5 - 0.7 metres per second. Above this velocity, soft deformable material may be swept through the screen. The screen can be cleaned by hand or mechanically. Cleaning should be done regularly to ensure that an adequate flow is maintained.

Except in hilly areas where water can be transported from the intake by gravity, water will have to be pumped up to a storage tank or treatment works. This can be done by pumping directly from the river or using a pump at the start of the supply line. In deeper intakes, a sump can be used from which water is pumped, with an inlet pipe running through the river bank. This has the advantage of the sump acting as a silt trap, thus removing potentially damaging debris from reaching the treatment plant or the supply line.

---

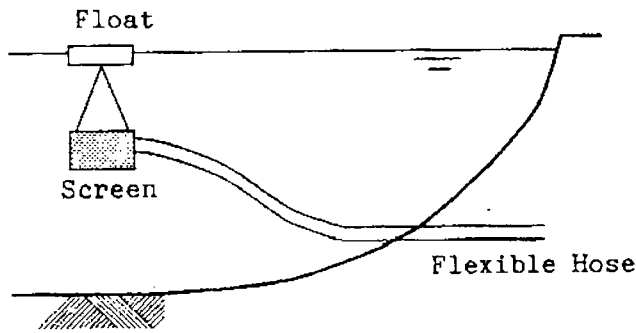
## *Lakes*

Water can be abstracted for drinking water supplies either from artificial (where there is a dam) or natural lakes. The quality of lake water varies widely. Human and animal faecal pollution is a major health hazard near the shore. In small lakes and ponds there is a high risk of faecal pollution, and if water from such a source is used it will require treatment.

In deep lakes, the intake should be set 3 - 5 metres below the surface, although in some cases this may need to be deeper - usually because of excessive algal growth on the lake surface, sometimes called an algal bloom. In shallow lakes, the intake should be sufficiently high above the lake floor to prevent the entrance of silt.

For small community water supplies, where the quantity of water needed is small, very simple intake structures can be used. If, for example, 30 litres of water per person per day is to be supplied and the peak intake is 4 times the average hourly water demand, 1000 people would require an intake capacity of 1.4 litres per second. A 150 mm diameter pipe would be sufficient to keep the entrance velocity in the pipe to 0.02 metres per second. If an entrance velocity of up to 0.12 metres per second is allowed, then a 60 mm diameter pipe can be used.

For small capacity intakes, simple arrangements using flexible pipe can be employed (see Figure 4).

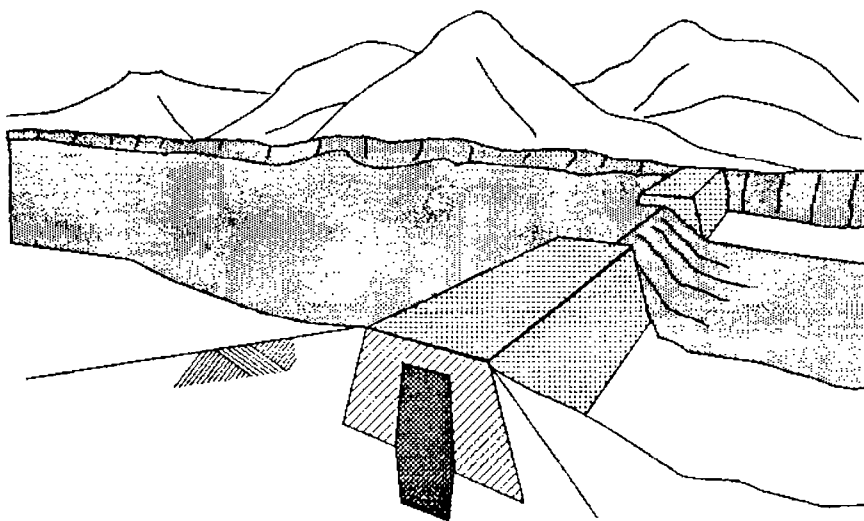


**Figure 4. Simple water intake**

### *Small dams*

Dams are structures that are built across a river or stream to block the flow of water and create an artificial lake. Artificial lakes may be used as a source of drinking water. Ideally, the dam should be constructed upstream of any permanent human habitation or activity, to reduce the risk of contamination of the lake water. Generally, water from a dam and lake will require treatment, as for any other surface water source.

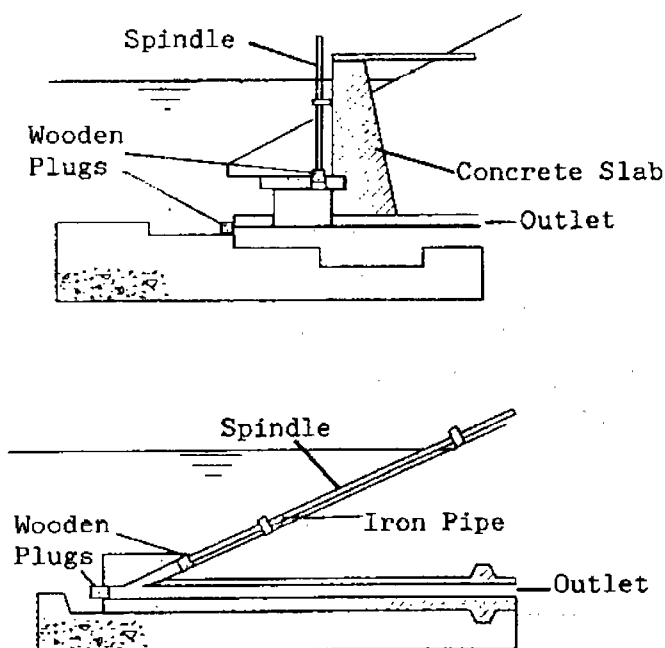
This Fact Sheet is only concerned with small dams of up to 6 m in height. Dams above this size require specialist construction techniques and experienced engineers to design them. In hot climates, the evaporation from the lake, or reservoir, will be very high; in these circumstances, the dam should thus be at least 3 m high to provide a year round water supply. Small dams may be constructed from a number of materials, but are most commonly made from earth. Figure 5 shows a simple small earth dam.



**Figure 5. A simple small earth dam**

**The following points are essential to the design of a small earth dam :**

- The dam must have a secure foundation to support the dam weight under all conditions.
- The dam should have an impermeable core of puddled clay, or concrete, to prevent water from seeping through it.
- The sides of the dam embankment should slope at an angle which will provide a stable structure. Commonly, a figure of 2 :1 (horizontal : vertical) is used for the upstream side and 1.5 :1 on the downstream side. The upstream side should be covered with a stone pitching (sometimes called a “rip-rap”).
- The top, or crest, of the embankment must be at least 2 m wide. The crest of the dam should be at least 1 m above the maximum anticipated water level under extreme flood conditions. This safety margin is called the freeboard.
- The dam should have an overflow channel to divert excess water under flood conditions. Water must never be allowed to flow over the top of the dam, as this will erode the downstream side of the embankment and weaken the dam.
- The means of abstracting water should be as simple and accessible as possible. Usually water is abstracted just upstream of the dam using a pump. Outlet pipes may be built through the dam, but this is difficult to do successfully and there is always likely to be seepage along the outside of the pipes. Figure 6 shows a simple outlet arrangement.



**Figure 6. Outlet and drain**

- Where the river water is used downstream, there should be an outlet for water to flow from the reservoir to the river bed downstream of the dam. This is called compensation flow. The amount of water discharged should be agreed upon by all the downstream communities which use the river.

---

## *Screens*

---

### **Intakes from surface water often need a screen or a series of screens for two main purposes :**

- Removal of floating and suspended matter of a size that might clog pipes, damage pumps or interfere with treatment processes.
- Clarification of water by removing suspended matter, even of small size. This is done to prevent clogging of any filtration systems and helps to make subsequent treatment more effective.

Bar screens normally consist of parallel steel bars spaced at 0.5 to 5 cm. The screens are angled at 60 - 75° for small material and 30 to 45° for large material. The screens can be cleaned manually or mechanically. Water flow to the screen should be low (0.1 to 0.2 metres per second). Once the water has passed the screen, it should have a velocity of at least 0.3 to 0.5 metres per second, to prevent any further settlement of suspended solids. The water flowing through the screen should flow no faster than 0.7 metres per second, otherwise soft deformable material can be forced through the screen.

---

## *Summary of maintenance tasks*

---

### *Every storm*

- Unless there is an automatic way of diverting the first flush of water away from the storage tank, disconnect the inflow pipe from the tank.
- Reconnect the pipe 15-20 minutes after the rain begins to fall.

---

### *Every week*

- Check the water level in the storage tank using a stick (which should be kept in a clean place and not used for any other purpose).
- If water level falls faster than normal there may be a leak. Check the tank for wet areas and repair.

---

***Every month***

- Clear roof or other collection surface, pipes and gutters of bird droppings, leaves and other rubbish.

---

***Every year***

- Repair leaks (replaster the inside of the tank if leaks are hard to find).
- Check and repair roof and other collection surface, and all gutters and pipes.
- Check mosquito net and screen on tank, and replace or repair if damaged.
- Drain the tank and clean out any sediment from the bottom.
- If work has been done on the tank, for example repairs, disinfect the tank with chlorine solution (see Fact Sheet 2.26 for information about disinfection of tanks).



# Water treatment

Groundwater sources should be protected and sources of contamination eliminated (see Fact Sheets 2.2 to 2.4). Protected groundwater sources generally provide good quality water and may require only terminal disinfection prior to public supply.

Surface water sources, such as rivers, streams, ponds and lakes, are often contaminated and are always open to contamination. For this reason, surface water will require treatment before being used for drinking purposes.

---

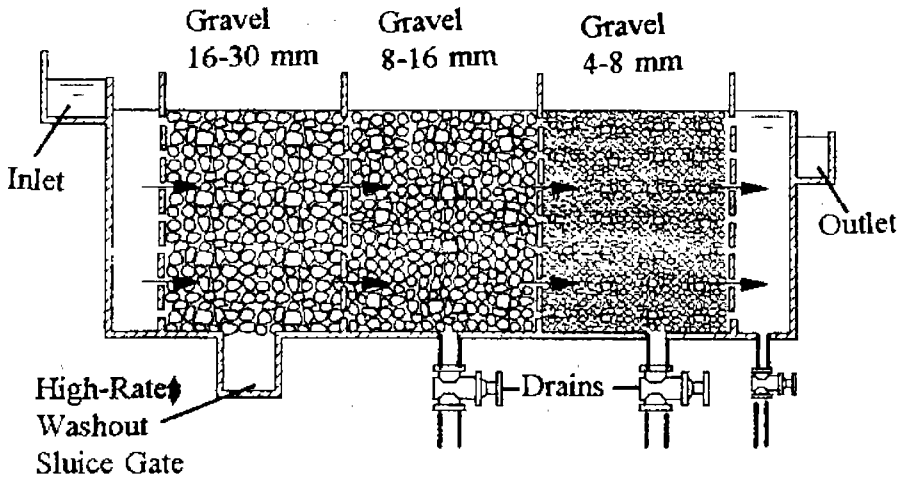
## *Water treatment processes*

The most commonly encountered water treatment processes are summarized below.

*Primary storage* is the storage of water after abstraction and before treatment. It helps to smooth variations in source water quality and quantity, and can provide a temporary reserve against short-term interruptions from the source. Primary storage should reduce turbidity considerably and assist in the reduction of pathogens (disease-causing microbes). In areas where schistosomiasis occurs, if water is in protected storage for a minimum of 48 hours then the risk of transmission is greatly reduced because the cercariae cannot find a host and will die. Although primary storage tanks should ideally be covered, this is not always practicable because of their large size. When they are uncovered, there will be evaporation losses and excess algal growth may occur. There is also the risk of introduction of pathogens by wild animals and birds. Primary storage tanks are easy to maintain but require large areas of land if they are to have a significant retention time.

*Pre-filtration* through coarse media such as gravel is used to remove suspended solids and to a lesser extent microorganisms from water. As pre-filtration reduces the turbidity of water it is especially useful as a pre-treatment prior to slow sand filtration. Operation and maintenance of pre-filters is generally straightforward. Much work has been done on pre-filtration in recent years and it now appears that upward flow of water through the filter medium is most efficient. Cleaning involves reversing the flow of water so that solids are removed through a drainage gate at the bottom of the filter bed. Most commonly three separate packs of gravel of decreasing size are used. A pre-filter is shown in Figure 1. Pre-filtration is described in more detail in Fact Sheet 2.11.

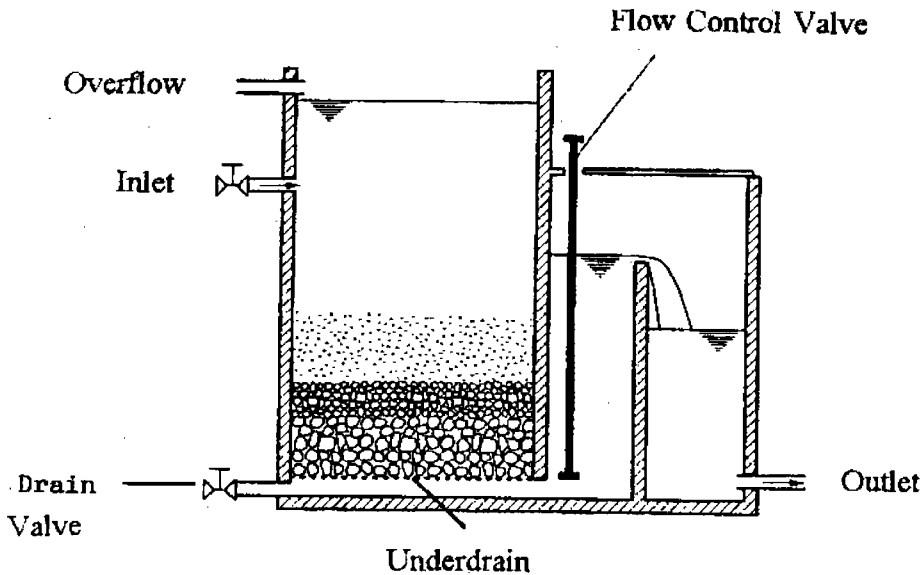
**Fact Sheet 2.8**



Section

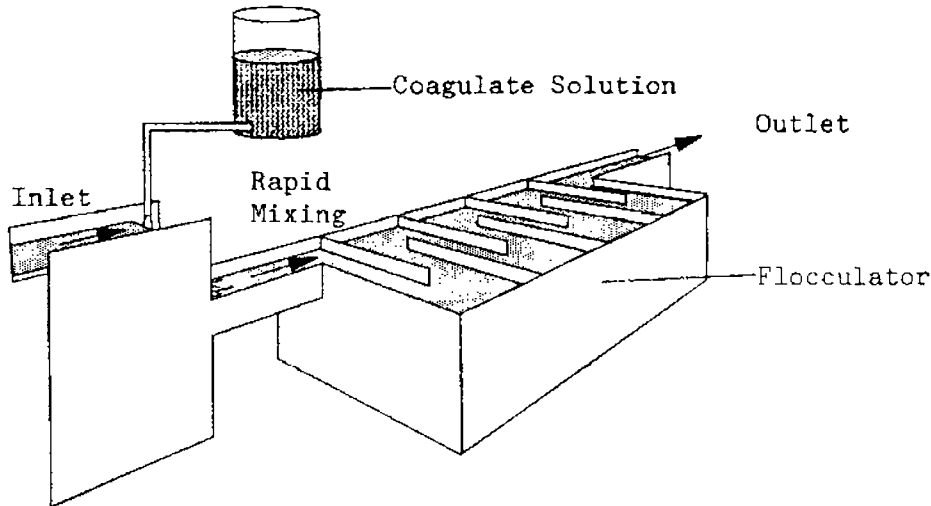
**Figure 1. A horizontal gravel pre-filter**

*Slow sand filters* use a form of biological treatment which is very efficient in the removal of pathogens from water. The filters use fine to medium sand through which water filters slowly. They require large areas of land and this makes them unsuitable for larger towns and cities. Slow sand filters are easy to operate and maintain but must be protected against turbidity in the source water, for instance by using pre-filtration. A simple slow sand filter is shown in Figure 2 and slow sand filters are described in more detail in Fact Sheet 2.12.



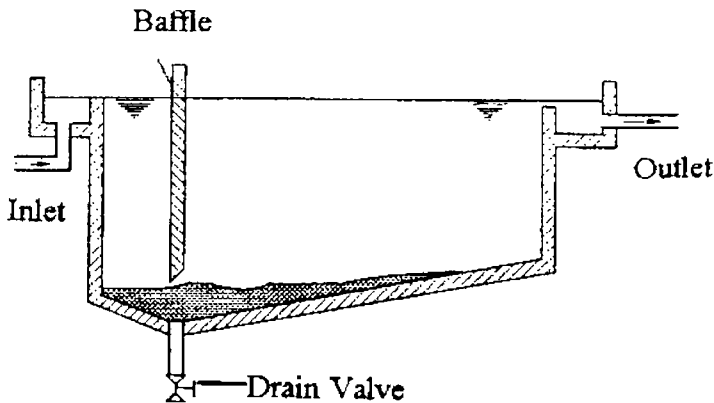
**Figure 2. A simple slow sand filter**

*Coagulation and flocculation* involve the addition of chemicals to water in order to improve the removal of suspended solids. The solids join together as “flocs” and are removed by sedimentation in a settling tank, or clarification. Careful process control is necessary and skilled operation and maintenance are essential for efficient coagulation and flocculation. Coagulation and flocculation are normally restricted to larger water treatment plants serving large towns and cities. A simple flocculator is shown in Figure 3. Coagulation, flocculation and clarification are described in more detail in Fact Sheet 2.13.



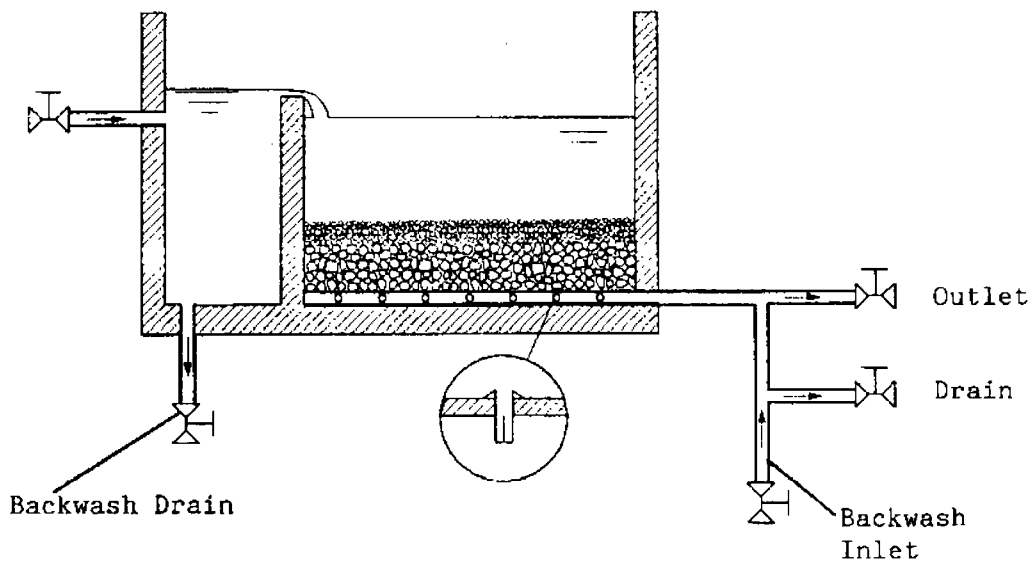
**Figure 3. A flocculator**

*Simple sedimentation* occurs in large settling tanks where water is stationary or flows slowly so that particles are able to sink to the bottom and settle. Settling tanks are often combined with slow sand filters and this combination of treatment technologies can be effective where source waters are not very turbid and turbidity is not due to small particles (clay and fine silt). Settling tanks are mainly used after coagulation and flocculation where the designs are often more complex. A typical simple sedimentor is shown in Figure 4, and is described in more detail in Fact Sheet 2.10.



**Figure 4. A simple sedimentor**

*Rapid sand filters* are tanks in which water passes under pressure through a filter medium, usually coarse sand. The tanks may be open, in which case the head of water above the sand provides the pressure to drive the filtration, or they may be closed metal tanks into which water is fed under pressure. These filters are cleaned regularly by back-flushing the sand bed with water. Rapid filters remove solids effectively. Because the flow rate is high, they do not occupy large areas of land ; but they are expensive to construct and require skilled operation and maintenance. For this reason, they are usually used to treat water in larger water treatment plants serving towns and cities. A gravity rapid sand filter is shown in Figure 5 and rapid filters are described in more detail in Fact Sheet 2.14.



**Figure 5. A gravity rapid sand filter**

*Disinfection* is needed for all water after treatment and should always be used where there is an increased threat from water-borne disease. Under most circumstances, chlorine is the disinfectant of choice for community water supplies. Disinfection is described in detail in Fact Sheets 2.16 to 2.28.

---

### *Siting abstraction and treatment*

Prior to treatment, it is important to select the most appropriate water source and its site of abstraction. This selection procedure should take into account water quality along with other factors such as cost. In particular, it is often possible to achieve a significant improvement in water quality by siting intakes above human settlements.

---

### *Monitoring of treatment*

It is essential that water treatment processes be monitored regularly in order to ensure their adequate functioning. Monitoring should involve :

- Verifying water quality during various stages of treatment and where it leaves the treatment plant. As a minimum, testing should be for thermotolerant (faecal) coliforms, turbidity/suspended solids and chlorine residual. Where coagulation and flocculation are practised, “jar” testing (for the optimum dose of chemical required) and pH testing should also be undertaken.
- Verifying that planned operation and maintenance is being undertaken and adequate records kept.
- Confirming that all processes are operating within design limits; for example, that filters and settling tanks are not over-loaded.



## **Flow measurement and control**

Water flow is measured to assess how much water is available for a supply and to check the quantity of water flowing through a system or treatment plant.

Flow control is essential in water treatment plants and for effective disinfection of distribution networks. Most water treatment processes require a controlled constant flow of water in order to operate effectively and efficiently.

---

### *Water source flow measurement*

The measurement of water flow is important in selecting the best source for a drinking water supply. The source has to be able to provide sufficient water to serve the population, either on its own or in conjunction with other sources. The flow of water sources should be measured to assess the amount of water they may provide. Flow is usually measured in cubic metres per second or litres per second.

Different sources of water require different methods of flow measurement and can be divided as follows : surface water, springs and wells. In all cases, water flow measurement should be done when the flow is at its lowest, usually at the end of the dry season, to assess whether the source is able to provide sufficient water all year round.

---

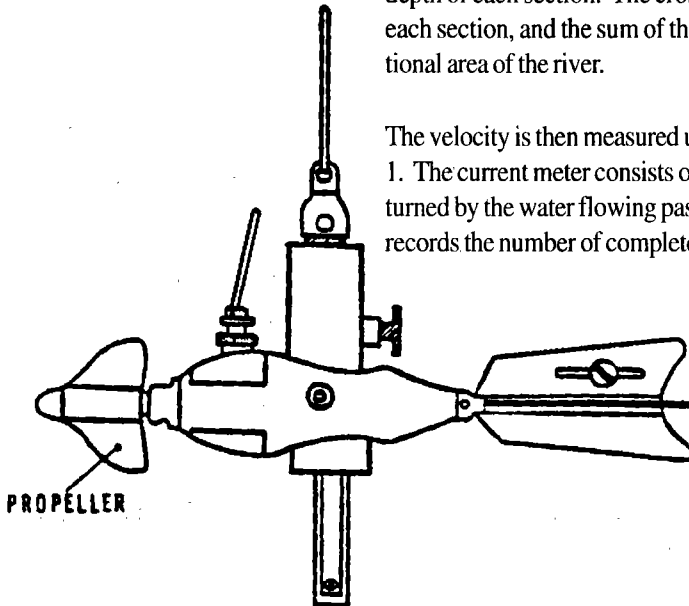
### *Surface water sources*

There are numerous ways to measure the flow of rivers and streams. Often all that is feasible is to make an initial assessment of flow as part of the selection of water sources. This means that only a limited number of flow measurements may be taken. There is a risk that a limited number of readings will not be representative of possible variation of the river flow. For this reason, it is important to interview members of the local community to try to find out if water flows and levels are often lower or higher than seen during measurement.

The two most common methods of flow measurement of surface water are : velocity-area method ; and overflow weir gauging.

### Measuring velocity and cross-sectional area

In order to calculate the flow of rivers, the velocity and cross-sectional area need to be determined. As the depth of the river will vary, the best method is to divide the stream into sections of equal width, often 1 metre, and measure the depth of each section. The cross-sectional area can then be calculated for each section, and the sum of the areas of all the sections will be the cross-sectional area of the river.

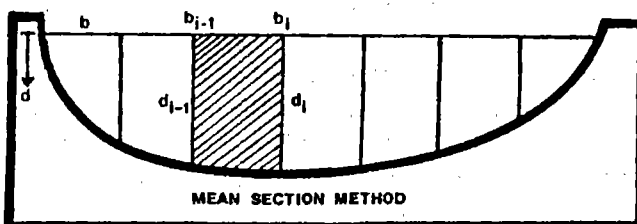


The velocity is then measured using a current meter, which is shown in Figure 1. The current meter consists of a propeller which points upstream and is turned by the water flowing past. The propeller is connected to a counter which records the number of complete revolutions the propeller makes in a set time.

Figure 1. A current meter

Average velocity in a river occurs at 0.6 of the total depth ; however in order to make a reasonably accurate estimate, the average velocity is found by taking two readings in each section, one at 0.8 and one at 0.2 of the depth. These are averaged to give the average velocity for each section. The area of each section is calculated and the flow for each section calculated. The flows in each section are then summed to give the overall discharge for the stream. Figure 2 illustrates this method.

$$Q = \frac{(v_{i-1} + v_i) \cdot (d_{i-1} + d_i)}{2} \cdot (b_i - b_{i-1})$$



where Q = discharge  
 v = velocity  
 d = depth  
 b = distance of measuring point (i) from a bank datum

Shaw E. M. 1988, Hydrology In Practice, VNR International

Figure 2. Velocity-area method<sup>1</sup>

<sup>1</sup> Shaw, E. M. *Hydrology in Practice*, Nostrand Rheinhold (UK). Hong Kong, 1989



## Gauging weirs

The most accurate way to estimate surface water flow is by using a gauging weir. These are structures which are placed across the stream to raise the water level and control the flow. Weirs can be permanent or movable structures which have an opening cut into the crest. Permanent weirs are more likely to be found where the stream or river is a source for a large water supply, or where hydrological measurements are regularly made. Movable or thin plate weirs can be very useful for programmes where many water supplies from small surface water sources are planned.

The water from the stream flows through the opening and must fall freely on to the stream bed below (see Figure 3).

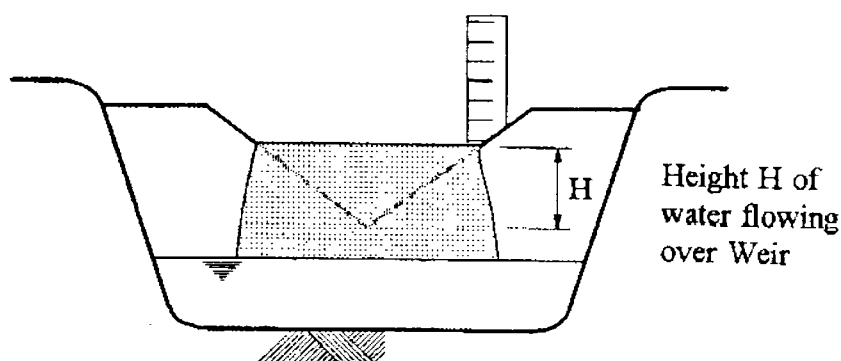


Figure 3. Weir

The flow of water in the channel can be determined by measuring the depth of water flowing over the weir. This is taken from the apex of the weir notch to the water surface and is called the “ head ”. The surface of the water below the weir must be at least 0.25 m below the crest to ensure that there is a clear overfall. The depth of water flowing over the weir should be measured some distance upstream of the weir, usually equal to 4 times the head.

For each type of weir there is a standard calculation which is used to relate depth of flow over the weir to discharge. These calculations can be found in standard texts on hydrology and hydraulics. The tables below give some examples of typical head-flow values for 90° and half 90° V-notch weirs.

### Head-flow values for a 90° V-notch weir

Head of water (mm)	Flow of water (l/sec)
50	0.8
60	1.2
70	1.9
80	2.6
90	3.4
100	4.5
110	5.6
120	7.0
130	8.6
140	10.3

Head-flow values for half 90° V-notch weir

Head of water (mm)	Flow of water (l/sec)
50	0.34
60	0.53
70	0.77
80	1.07
90	1.44
100	1.86
110	2.36
120	2.92
130	3.56
140	4.28

Flumes can also be used to measure the flow of small streams. These are structures placed across the stream which instead of reducing the depth of the stream, as a weir does, reduce its width. The discharge is calculated from the head of water flowing through the flume. For each type of flume, there is a standard equation to calculate discharge. These equations can be found in standard texts on hydrology.

In large water supplies, where one or more rivers supply a town, it will be worthwhile to install permanent flow measurement stations. Once these are established, it is possible to prepare graphs so that only depth need be measured in order to find the flow.

---

## *Springs*

The flow of water from a spring is usually termed the yield. The yield is determined by the amount of water which percolates into the aquifer, and how much water is stored in the aquifer. The yield may vary with the season, depending on the type of spring.

Gravity springs occur where groundwater emerges on the surface because an impermeable layer prevents it from seeping downwards, or the water table is at the same height as the land. The yield of gravity springs is likely to vary with the season. Measurements of yield should therefore always be done when the flow is least, usually at the start of the wet season. As springs rely on rainwater percolating through the ground to the aquifer, there will be a time lag between the onset of the wet season and an increase in the yield of gravity springs.

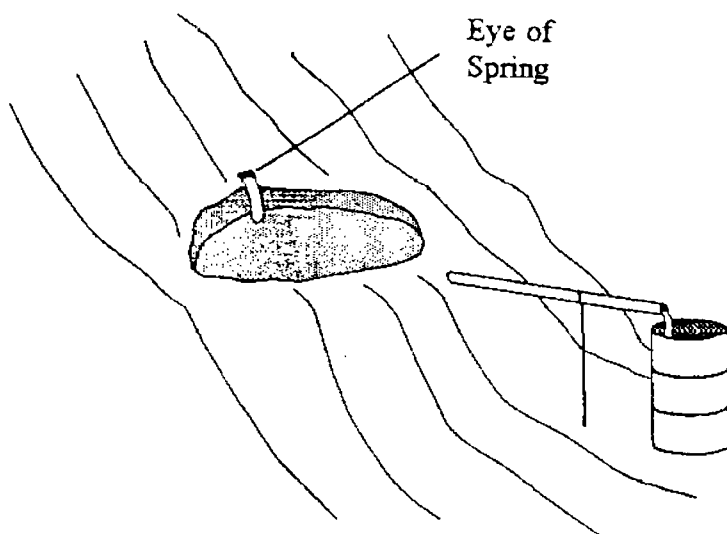
Artesian springs occur where groundwater emerges at the surface after confinement between two impervious layers of rock. Artesian springs tend to have a constant yield, as the aquifer is confined under pressure and so produces a constant amount of water.

To measure the yield of a spring, an overflow gauging weir may be used as described above. If this method is used, then care must be taken to ensure that the level of water behind the weir does not rise above the level of the eye of the spring.

An alternative method is to divert the spring flow into a container of known volume. The time taken for the container to fill is measured and the yield in litres per second easily calculated. This method is illustrated in Figure 4.

It is a good idea to take several measurements of the yield and average the results. The main problem in spring yield measurement is to ensure all the flow of the spring is collected. The best way is to build a small earth dam around the spring to create a pool. A length of pipe is laid through the dam and leads to the container. Whilst the pool is filling, no water should run into the container but should be diverted. Once the pool has reached a level when it is no longer filling up, the water should be allowed to run into the container and the yield measured. When the pool has reached a steady level, the water flowing out of the pipe is equal to the water flowing into the pool from the spring.

If it is not possible to trap all the spring water, the yield can still be estimated. As long as the part of the yield measured exceeds the requirement, then the source can be used.



**Figure 4. Measuring the yield of a spring**

## *Wells and boreholes*

The amount of water that comes from a well or borehole is termed its yield. The measurement of the yield of a groundwater source is important to assess the viability of the source and the depth of well required. Measurements of yield should be taken when the water table is at its lowest level. Usually this is at the start of the wet season, as there is a time lag between the onset of the rains and water table rising. Artesian wells, like artesian springs, will maintain a steady level all year.

The accuracy and the detail of the measurements of groundwater yield required will vary with the type of well to be sunk.

Where wells or boreholes are to be sunk for small isolated communities, there need only be basic tests. An initial pilot borehole should be sunk to determine the depth of the water table. A test of the yield of the aquifer can also be made at this stage but may not give accurate results.

If a handpump or other manual means of raising water is to be used, then a quick pump test is all that is required once the well is completed. All the water in the well, or as much as possible, should be pumped out. The rise of the wa-

ter back into the well, to the point where it regains its former level, is timed. The yield can then be roughly calculated from the diameter of the well, the height of the water column and the time taken for the water to rise. This can be compared with the requirements of the community and a decision made on whether the well needs any deepening.

Where a large number of boreholes are to be sunk in an area, all equipped with pumps, a full pumping test should be undertaken. This is particularly important where electric or other motor pumps are to be used.

Where electric or other motor pumps are used, the "ideal yield" of the borehole (where output meets requirements and pumping costs are minimized) should be found. This allows the correct pump to be selected for the borehole and the required pumping rate to be determined. Pumping tests also help to determine the aquifer's characteristics and how the exploitation of the aquifer at one location will affect it at other points. This helps to site boreholes so that they do not interfere with the water available to other boreholes, and to ensure that there is no excessive lowering of the water table.

The interpretation of pumping test results, the calculation of aquifer properties and the effects of adjacent boreholes on well yield is beyond the scope of this Fact Sheet. Standard texts on hydrology and hydrogeology should be consulted, and expert advice sought for further information.

---

## *Measurement and control of water flow in water treatment*

Water flow must be controlled continuously and accurately during treatment. This is important because, in most treatment processes, if the flow of water is not constant (within set limits), the treatment may be inefficient and the water supplied of poor quality. Flow measurements give an indication of the efficiency of a process and indicate if filter beds need cleaning. The measurement of flows through a treatment plant must be done regularly. Further information on water treatment processes is given in Fact Sheets 2.10 to 2.14.

---

### **Methods of flow control**

Various methods of water flow control can be used. Valves can be set to allow specific flows of water through a treatment plant, either at the inlet or the outlet. If a regulating valve is fitted, it will require regular (possibly daily) adjustment to ensure that a constant flow is maintained. A globe valve is often used, as it is a variable rate valve, although sometimes a gate valve may be used. With this method, the flow from the outlet must be recorded regularly in order to assess when the regulatory valve needs to be opened. A V-notch weir or a flume can be used for this, or if the flow is large enough, a flow meter.

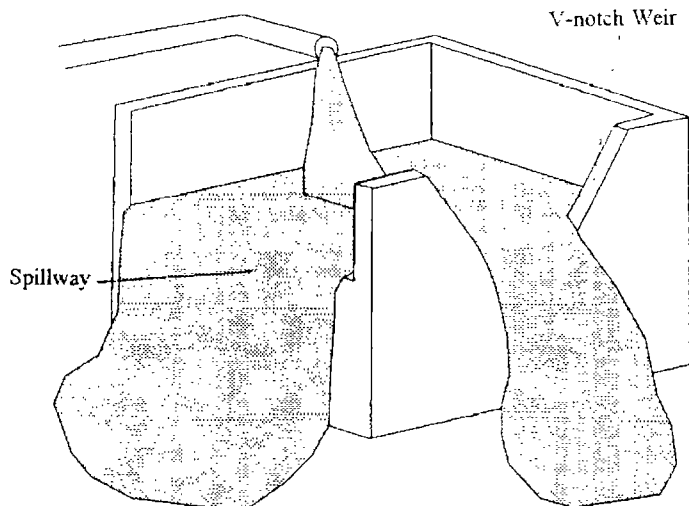
Float controlled valves can also be used to regulate flow. These are valves which close when the water reaches the required level in an inlet tank.

The need for constant adjustment is a major drawback with the use of valves, as an operator is required for the plant. Automatic devices are generally preferred. Although float controlled valves can be used they are not always reli-

able and are prone to breakdown. Where the influent water is turbid or contains corrosive chemicals, valves may become worn and no longer ensure a constant flow.

The most common automatic flow control method is the use of flumes and weirs. These are the same devices that are used to measure the flow of surface water, although they may be smaller. The flow is controlled by the amount of water allowed to pass over the weir or through the flume. In small community water supplies, V-notch weirs are the most common form encountered as they are the most accurate at low flows. The flow of water over the weir can be calculated from the height of the water above the weir crest, or the head, by using calculations given in standard texts on hydrology or hydraulics. The tables above give values for flow in relation to depth.

When a V-notch weir is used to control the flow, a spillway is constructed as well. The spillway acts as a flow control when the influent flow rate exceeds the rate required, by allowing the excess water to flow over it. Figure 5 shows a typical example of V-notch weir with a spillway used in a slow sand filter.



**Figure 5. V-notch weir and spillway**

Where the water supply is regularly disinfected, flow measurement and control are needed for many types of disinfectant dosing. Disinfection is covered in detail in Fact Sheets 2.16 to 2.28, which include information concerning dosing equipment and requirements.

# Simple sedimentation

Surface waters contain sand, grit, silt and other suspended solids which can damage pumps, block filters, clog pipes and filter screens, reduce storage capacity and reduce the effectiveness of disinfection.

Sedimentation can remove significant amounts of suspended solids from water. Numbers of pathogenic (disease-causing) microorganisms are also commonly reduced as they are often attached to particles and will be removed with them. Fine silt or clay particles are unlikely to be removed unless coagulating chemicals are added to the water and a type of settling tank used. Coagulation, flocculation and clarification in water treatment are described in Fact Sheet 2.13.

---

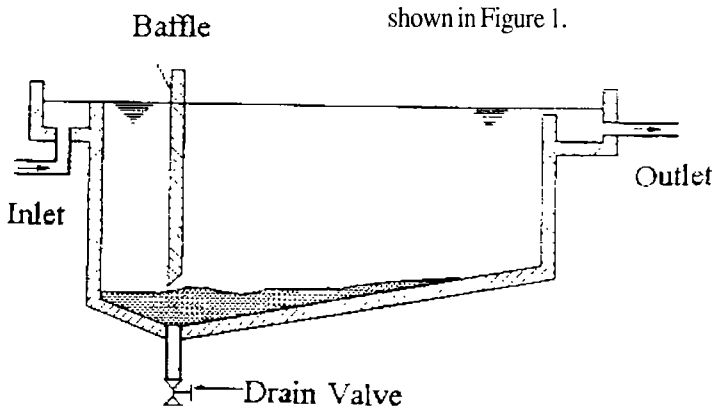
## *Grit chambers and channels*

Grit or coarse suspended solids can be removed in a grit tank or channel. These are essentially coarse sedimentation tanks in which the water flows at a maximum velocity of 0.75 m/sec. The retention time of the tank need only be a few minutes. Finer suspended matter can be reduced by passing the water slowly through a settling tank.

---

## *Simple settling tank*

A sedimentation tank is designed for a specific retention time, ensuring flow with minimum turbulence. The design and arrangement of inlet, outlet and baffle structures are important. In addition, the design must allow for the removal of solids which have accumulated at the bottom of the tank. This is most commonly achieved by positioning a large diameter drain valve at the lowest point of the tank. The floor of the tank should slope towards this valve so that solids tend to flow towards this point. A typical simple settling tank is shown in Figure 1.



**Figure 1. Simple settling tank**

The retention time of water in a sedimentation tank is usually about two hours.

---

## *Sanitary inspections of simple settling tanks*

Sanitary inspections of simple settling tanks should be carried out regularly to ensure that the tank is regularly and properly cleaned and that it is functioning correctly (see Fact Sheet 2.1). The key points and observations to make during a sanitary inspection are :

- The drain valve should be functional and greased.
- The floor of the tank should be regularly cleaned.
- The turbidity of the water at the outlet should be 70-90 per cent lower than the turbidity of the raw water. If the turbidity reduction is less than 50 per cent the tank should be drained and cleaned.

---

## *Key design features*

Typically the inlet structure of the settling tank will include a perforated vertical baffle a little way forward from the inlet pipe to distribute the water evenly across the tank. Water must flow evenly into the tank to avoid turbulence and areas of stagnation. There may also be a weir across the width of the tank before the baffle. The rapid transit of water across the tank must be avoided as the retention time will be too low to allow the suspended solids to settle out.

*The settling zone is the area where the solids settle to the bottom of the tank. The important feature is the retention time of the water here. For most waters a minimum retention time of two hours is required to remove over 50 per cent of the suspended solids in the raw water. Theoretical and real retention times are often different because of poor settling tank design.*

*The outlet of a settling tank is a weir which collects clarified water from the top layer of the tank after the settling zone.*

*The sludge zone is the area where the solids accumulate at the bottom of the tank. It should slope towards the drain.*

---

## *Operation and maintenance of simple settling tanks*

Regular maintenance of simple settling tanks is limited to removal of the accumulated solids. This can be done by means of the drain valve connected to the lowest point of the settling tank.

# Pre-filtration

Roughing pre-filters reduce the quantity of suspended matter in water prior to other treatment processes. They are most commonly used with slow sand filtration (covered in Fact Sheet 2.12). Roughing pre-filters also contribute to the removal of microorganisms from water during treatment.

In a typical roughing pre-filter, water passes slowly through packs of gravel of different sizes where suspended matter is trapped. Flow through the gravel may be horizontal, vertical upflow or vertical downflow. The upflow configuration is the most efficient and facilitates hydraulic cleaning. The accumulated material trapped in the filter must be removed periodically by cleaning. Cleaning is often achieved by rapidly draining down the filter through a fast-opening gate, so that the particles are re-suspended from the gravel and leave the filter in the wastewater. In practice, it is often found that the gravel needs to be dug out of the filter periodically, washed and replaced.

Roughing pre-filters, like coagulation-flocculation clarification, are used to remove suspended matter from the water. Roughing pre-filters have the advantage that no chemicals or dosing equipment are required, and operation and maintenance requirements are lower and more simple.

Roughing pre-filters are especially useful in small and medium-sized water supply systems where they are often combined with slow sand filters. Pre-treating water before slow sand filtration minimizes clogging of the slow sand filters by suspended matter and therefore helps ensure their optimum performance.

---

## *Sanitary inspections of roughing pre-filters*

Sanitary inspections of roughing pre-filters should be conducted regularly to ensure that they are functioning properly and that an adequate water supply is maintained (see Fact Sheet 2.1). The key points and observations to make during a sanitary inspection of a roughing pre-filter are :

- The turbidity of the water leaving the pre-filter should be less than 10 TU. There should be a 70-90 per cent reduction in turbidity between the water at the outlet and the raw water.
- The flow rate through the filter should be controlled in the range of 0.5-1 metre per hour.
- The regularity and effectiveness of cleaning should be checked. The latter is done by analysing a sample of gravel from the filter immediately after cleaning to measure the silt content.



- The filter and filtrate should be protected from birds and animals.
- The pre-filter must not have any cracks that allow water in the filter to leak out or surface water enter the filter.

---

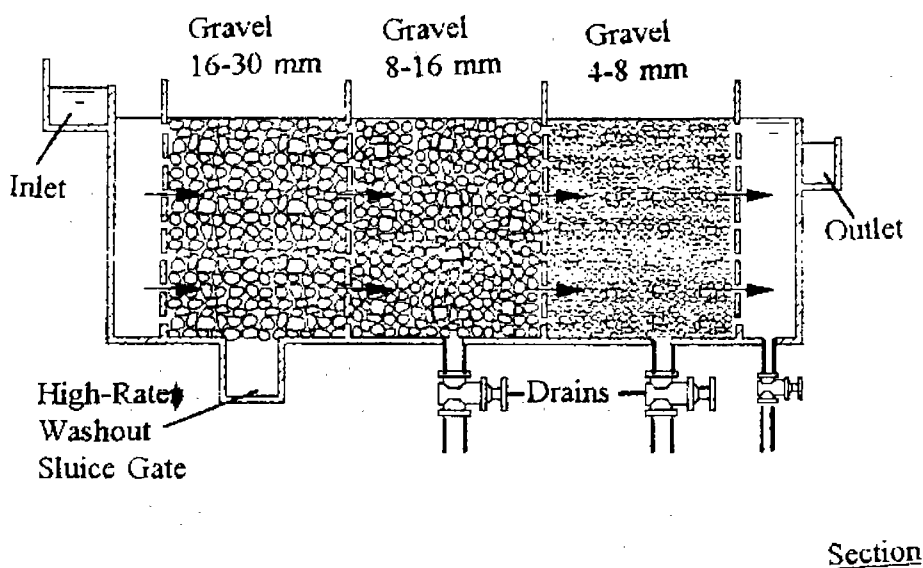
## Configuration

---

### Efficient gravel pre-filters have the following requirements :

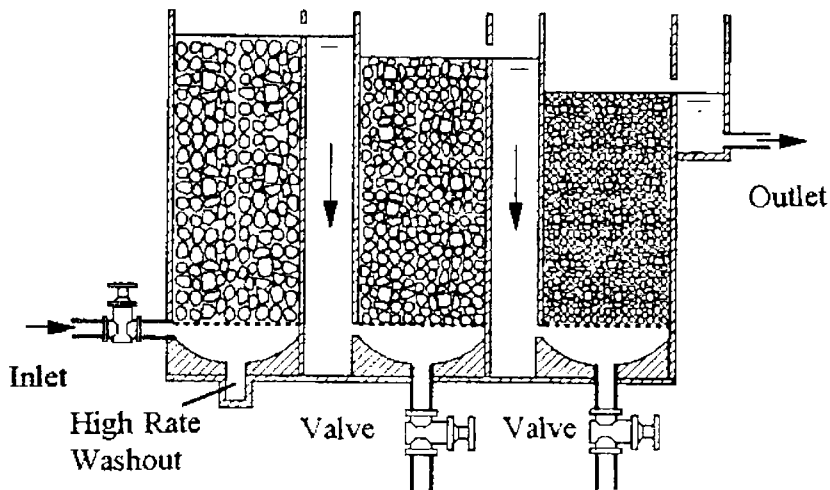
- Several sections (usually three) each filled with a different size of gravel.
- For a three section gravel pre-filter the sizes of gravel used are :

First section	16-30 millimetres
Second section	8-16 millimetres
Third section	4-8 millimetres
- The largest size of gravel is used at the raw water inlet, and gravel size gets smaller towards the outlet of the filter (see Figure 1).
- Water flow in pre-filters may be horizontal (see Figure 1), vertical upflow (see Figure 2) or vertical downflow. The vertical upflow configuration is now preferred.



---

Figure 1. Horizontal gravel pre-filter



**Figure 2. Upflow gravel pre-filter**

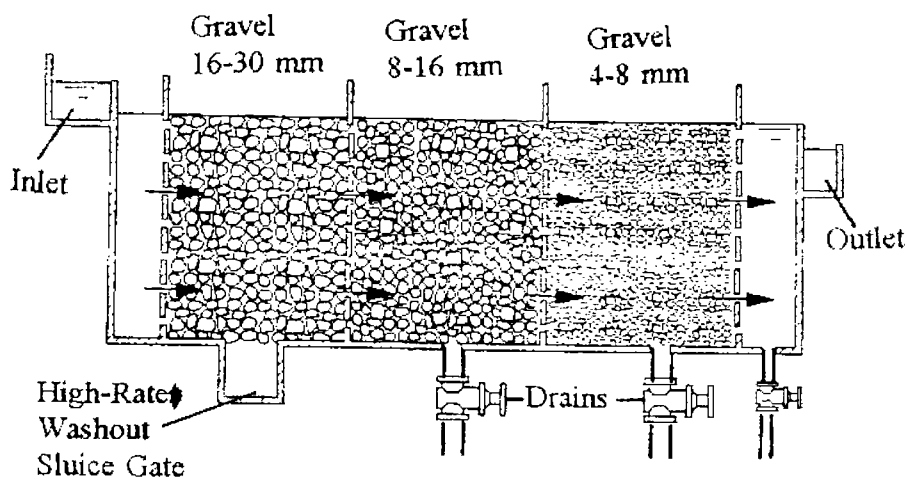
## *Operation and maintenance*

### **The operation and maintenance of roughing pre-filters is relatively straightforward.**

- **Turbidity** : check and keep a log of the turbidity of the water entering and leaving the pre-filters. Water leaving the filter should have a turbidity of less than 10 TU (see Fact Sheet 2.33). If turbidity is above this value, the filter may need cleaning or the flow rate may be too high.
- **Flow rate** : the flow rate of the raw water through the gravel pre-filters must be controlled, for example using a V-notch and weir at the inlet. For horizontal flow pre-filtering, flow rates should be between 0.4 and 1.0 m/hour. Check and adjust the flow rate of the gravel pre-filters using the V-notch at the inlet (see Fact Sheet 2.9). Keep a log of flow rates.
- **Cleaning** : the gravel pre-filters should have sloping floors and a channel leading to rapid opening wash-out gates to allow hydraulic cleaning of the filters. Close the outlet valve or gate and allow the filter to fill with water. Next, open the wash-out gates, causing the filter to drain rapidly carrying much of the sediment with the wash-out water. Close the wash-out gates and allow the gravel pre-filters to fill again.

# Slow sand filtration

A small-scale slow sand filter is a tank, usually uncovered, containing a set of underdrains covered with graded gravel which supports a bed of fine sand. The tank is filled with water to above the level of the sand. The water passes down slowly through the sand to the underdrains and is purified as suspended particles and microbes are removed in the sand. Figure 1 shows a simple slow sand filter.



Section

**Figure 1. A simple slow sand filter**

Incoming water must be relatively clear, with turbidity below a maximum 20 TU and ideally an average reading of below 10 TU.

After several weeks or months the top 0.5-2 cm of the sand becomes clogged and reduces the rate at which water can flow through the sand. When this happens, this top layer should be removed to restore the filtration capacity. Water should be allowed to flow through the filter for one or two days before the filter is put back into operation.

Flow control is essential and can be done at the inlet or outlet. A minimum head mechanism to prevent drying of the bed if the source of water is interrupted is essential, particularly where the source flow is variable.

Although slow sand filters are most commonly used for community water supplies, they can be built to serve individual households. These units generally work on a variable flow rate and because of this are likely to be much less efficient.

---

## *Sanitary inspections of slow sand filters*

Sanitary inspections of slow sand filters should be carried out regularly to ensure that they are functioning correctly and that an adequate water supply is maintained (see Fact Sheet 2.1). The key points and observations to make during a sanitary inspection of a slow sand filter are :

- The turbidity of the inlet water should be below 10 TU.
- The turbidity of the outlet water should be below 5 TU.
- The flow rate in the filter should be constant and in the range 0.1 to 0.3 metres per hour.
- The depth of sand in the filter bed should be at least 0.7 metres.
- The filter should have a minimum head device which is in working order and in operation.
- The tank should have no leaks which would allow filter water to escape and surface water to enter.
- Sand removed during cleaning should be washed and restored.

Records of all the above and cleaning records should be checked.

---

## *Advantages and disadvantages of slow sand filters*

---

### **Slow sand filters have the following advantages :**

- Very effective in improving the microbiological and physicochemical qualities of water.
- Very easy to operate and maintain.

---

### **Disadvantages of slow sand filters are :**

- Vulnerability to clogging when the incoming water is of high turbidity ; when dealing with such waters, pre-treatment, such as sedimentation or roughing pre-filtration, is required.
- Large areas of land are required on which to build the filter.

---

## *Factors influencing slow sand filtration efficiency*

The removal of microbes and organics in a slow sand filter is a biological process. The efficiency of the filter is therefore affected by time, oxygen, temperature and the need for beneficial microbes in the water to grow. These are described below :

---

### **Time**

The time available for the reactions to take place in the filter bed is determined by the sand depth and the flow rate ; these are discussed in more detail below, under “ Slow sand filter installations ”.

---

### **Oxygen**

The activity of the bacteria in the filter bed uses up oxygen. If the amount of oxygen in the incoming water is low or it has a high organic content, the microbial reactions will be less effective and the bacterial quality of the outlet water will decrease.

---

### **Temperature**

This is difficult to control, although filters can be covered in cold weather.

---

### **Maturation**

The microorganisms in the filter which remove bacteria from the water take time to establish themselves. Slow sand filtration therefore operates less efficiently when it is first commissioned and after cleaning. Thus as long as possible should be left between each cleaning of the filter. Keeping the raw water turbidity as low as possible, by pre-treatment if necessary, is therefore important.

---

## *Slow sand filter installations*

From experience gained in building slow sand filters, some general guidelines for filter design have been established as follows :

---

### **Population to be served**

Slow sand filtration is more cost effective than rapid sand filtration for populations up to 30,000

and possibly considerably higher.

---

### **Raw water quality requirements**

Incoming, or influent, water should not be too turbid, not exceeding 20 TU and ideally below 10 TU.

The most important raw water characteristic, however, is that the intake must be continuous and constant. Pumped systems will require storage facilities to ensure a constant supply rate.

The filter bed must not be allowed to dry out as this will kill the microorganisms which remove bacteria in water and cause a loss of purification efficiency.

---

### **Pretreatment**

Where high peaks or high mean turbidities are present in the water, some form of pretreatment is required. This can take the form of gravel pre-filtration, sedimentation or primary storage, all of which remove suspended solids from water. Gravel pre-filtration is particularly applicable to small community water supplies, with horizontal and vertical upflow filtration being the most common.

---

### **Inlet structure**

This should be designed to allow the water to enter the filter without disturbing the bed. This is usually done by using a plinth at the level of the sand to disperse the force of the falling water. To assist in the cleaning, all of the inlet, overflow or outlet structures should be designed to allow rapid drain-down before cleaning.

---

### **Filter bed**

The depth of the bed affects the time available for treatment and so its efficiency. A minimum depth of 70 centimetres is required for the proper functioning of the filter bed. As about 2 centimetres will be removed during each cleaning, it is a good idea to add extra sand initially. The initial sand depth should therefore be at least 1 metre.

A minimum of two filter beds should be included in any slow sand filtration installation supplying a community water supply to ensure that water can be passed through one filter whilst the other is being cleaned.

---

### **Supernatant**

This is the incoming water which lies on top of the sand to provide an adequate head of water over the filter.

Where flow control is practised at the inlet, clogging will cause the supernatant to rise. An overflow is required to take off excess water about 1 metre above the sand bed and once this level is reached the filter should be cleaned.

---

### **Filter medium**

Sand is the most commonly used medium, although other granular materials, such as burnt rice or a mixture of charcoal, sand and gravel, have been used.

The most important characteristic of the filter medium is the diameter of sand grains and their uniformity or size range. The sand must have a low silt content; river sand is preferred as it has less soluble salts in it. The filter medium should be of uniform grain size to make sure that the pores, or holes, between grains are the same size so that the filter's efficiency should be equal over the bed.

## Underdrains

These ensure that filtration is uniform and takes place over the full bed. Underdrains are usually composed of perforated pipes, such as plastic drainage pipes, or a false floor. Examples of underdrains are shown in Figure 2. In all cases, the underdrains are covered by a layer of gravel.

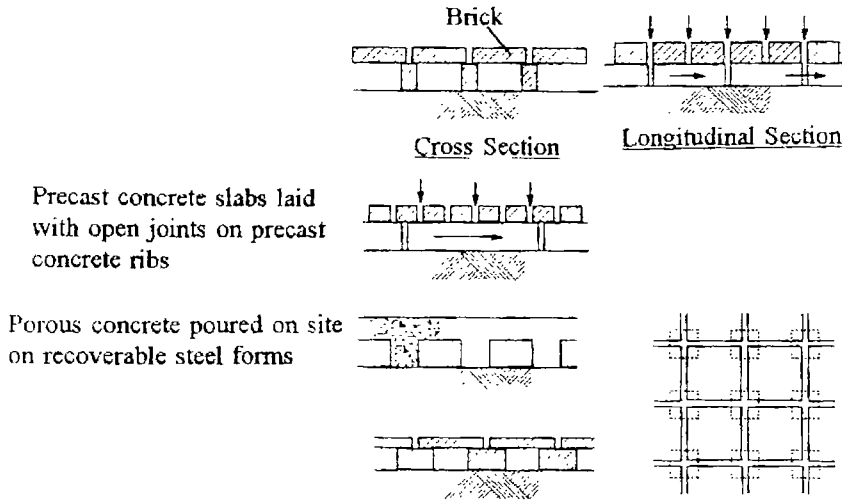


Figure 2. Examples of underdrains<sup>1</sup>

## Outlet structure

This is used to prevent water being siphoned off and can also be used to re-aerate water if a weir is installed.

If a weir is used, it should be positioned above the level of the sand bed to prevent the sand drying out if the inflow is interrupted for any reason. The outlet should also allow back-filling through the underdrains with clean water after commissioning or re-sanding.

## Flow rate

Flow rates vary, but should be between 0.1 and 0.3 metres per hour.

## Flow control

Maintenance of a constant flow through the bed is important for filter efficiency. Flow control can be practised at the inlet or the outlet.

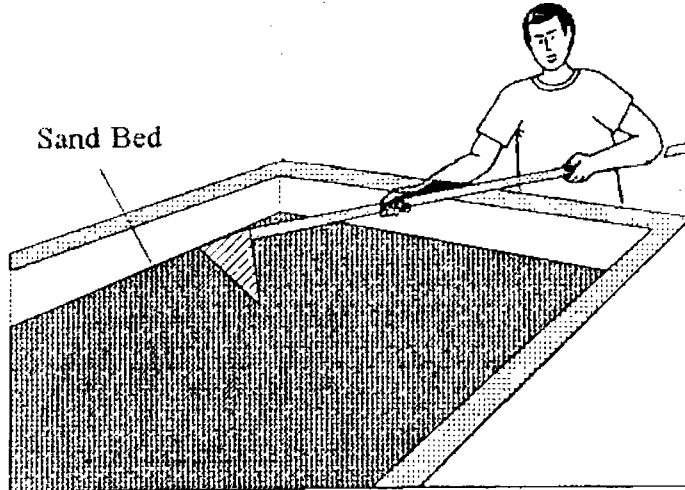
When the flow is controlled at the outlet, an outlet valve must be adjusted frequently, often daily, or output will fall. This ensures the maximum retention of water even at the beginning of a filter run. This method maximizes treatment efficiency but increases operator involvement.

Inlet flow control is often by gate valve plus a V-notch weir. As the resistance of the filter bed increases, the water level rises. When it reaches the overflow pipe the bed should be cleaned. Inlet flow control requires less operator involvement but decreases filter efficiency slightly.

<sup>1</sup> Hofkes, E.H. (ed), Small community water supplies, International Water and Sanitation Centre, and John Wiley and Sons, The Hague, 1981

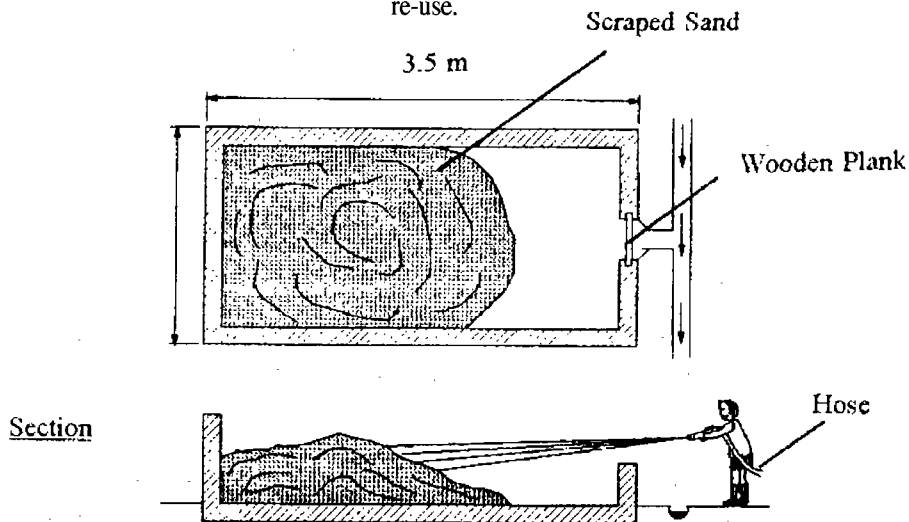
## Maintenance

Slow sand filters are very easy to maintain. Once the bed becomes clogged the top layer of sand is removed, as shown in Figure 3. To do this, the water in the bed is drained to 30-40 cm below the top of the bed and the top layer scraped off.



**Figure 3. Filter cleaning**

When this has been done, filtered water is allowed back through the system from the underdrains up to cover the sand layer. As this water flows through the bed, raw water may be re-introduced. It will, however, take 1-2 days before the bed is functioning properly. It may therefore be a good idea to re-filter the first raw water filtered after cleaning. The sand which was removed should be washed immediately (see Figure 4) to prevent it putrefying and then stored for re-use.



**Figure 4. Sand washing**

When the depth of sand in the bed has reached the minimum level of 0.7 metres, the bed must be re-sanded. An additional 0.3 metres of sand should be removed before the fresh sand is placed on the bed. Once the new sand is installed, this old sand can be replaced on top to promote the growth of bacteria.

An example of the schedule of activities for a slow sand filter caretaker is presented in the table below.



---

## *Slow sand filter maintenance tasks*

---

---

### **Daily**

- Check the raw water intake (some intakes may be checked less frequently)
- Check and adjust the rate of filtration
- Check water level in the filter
- Check water level in the clear water well
- Sample and check water quality
- Check any pumps
- Enter observations in the logbook of the plant

---

### **Weekly**

- Check and grease any pumps and moving parts
- Check the stock of fuel ; order more if necessary
- Check the distribution network and taps ; repair if necessary
- Communicate with users
- Clean the site of the plant

---

### **Monthly**

- Scrape the filter beds
- Wash the scrapings ; store the retained sand

---

### **Yearly**

- Clean the clear water well
- Check that filter and clear water well are watertight

---

### **Every two years**

- Re-sand the filter units
-



## Coagulation, flocculation and clarification

Coagulation, flocculation and clarification processes are used when a water source contains a large amount of fine suspended matter, for example silt or mud. If this type of water flows into a sand filter, the filter will soon block and stop working. The three processes are used together to make the water clean enough for filtering.

*Coagulation is a chemical reaction which occurs when a chemical, or coagulant, is added to the water. The coagulant encourages colloidal material in the water to join together into small aggregates or "flocs". Further suspended matter in the water is then attracted to the flocs. Rapid mixing of the water and coagulant is important to ensure thorough and even distribution of the coagulant.*

*Flocculation is a slow gentle mixing of the water to encourage the flocs to form and grow to a size which will easily settle out. This mixing is often done in a chamber or a series of chambers.*

*Clarification is the final part of the process and allows the large flocs containing much of the suspended matter to sink to the bottom of a tank or basin, while the clear water overflows and is then further treated.*

---

### *Sanitary inspections of coagulators, flocculators and clarifiers*

Sanitary inspections of coagulators, flocculators and clarifiers should be carried out regularly to ensure that they are functioning properly and that an adequate water supply is maintained (see Fact Sheet 2.1). The key points and observations to make when conducting a sanitary inspection are :

- Check and record the turbidity of the water flowing into the plant and leaving the settling tank. The water leaving the settling tank should have a turbidity of less than 5 TU.
- Check that dosing equipment for coagulating chemicals is working correctly. Use coagulant stock in rotation so that older stocks are used first.
- Keep records of chemicals used ; maintain stocks ; order replacements as necessary.
- Check and keep record of flow rates ; ensure that they are within design ranges.
- The coagulator, flocculator and clarifier should all be structurally sound and have no leaks where untreated water can enter.

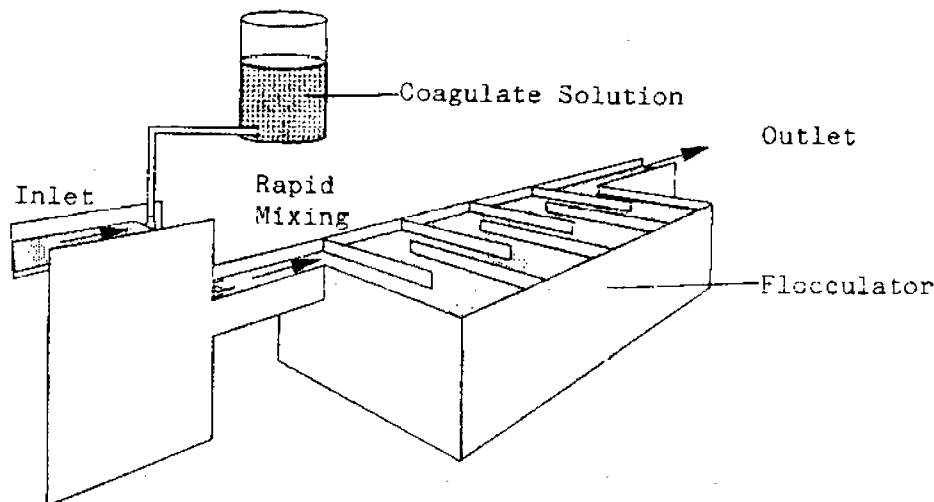
## *Operation and maintenance*

The operation of coagulants, flocculators and clarifiers requires trained operators. It should be clear who is responsible for the activities identified. Maintenance work should be undertaken regularly and be well planned. The key points for the operation and maintenance of coagulants, flocculators and clarifiers are shown below.

*Chemical stock. There should be a good stock (at least sufficient for one month of operation). Chemicals should be dated on receipt and used in rotation ; that is, the oldest chemicals should be used first. If chemicals are past their " use by date " (they are too old), they should not be used.*

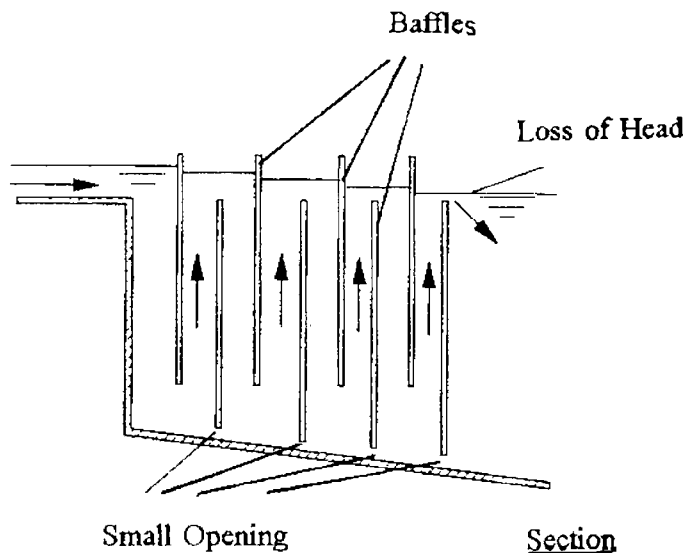
*Dosing control. Correct dosing of coagulant chemicals is very important for efficient and effective removal of suspended solids. Samples of raw water should be taken regularly, and tested with a range of coagulant concentrations to determine the optimum dose rate of coagulant. This test is known as the " jar test " and is described below. The results should be used to adjust the coagulant dose.*

*Rapid mixing of the water and coagulant chemicals at the point where the chemicals are added is essential. This may be achieved with a mechanical mixer or by hydraulic means, such as a weir or hydraulic jump, as shown in Figure 1.*



**Figure 1. Rapid mixing of coagulant**

Flocculation should be achieved by gentle mixing so as to maximize the number of collisions between suspended particles and flocs, without breaking the flocs up through rapid mixing. Flow rates in hydraulic flocculators should be in the range 0.1 to 0.3 metres per second, with a retention time of at least 30 minutes. A simple flocculator could be a large tank with baffles to encourage gentle mixing (see Figure 2). Where mixing is mechanical, mixers should work at a peripheral speed of 0.1 to 0.6 metres per second.



**Figure 2. A simple flocculator**

Plant layout. The flocculator and clarifiers should be located close to one another and water should flow slowly between them so as not to break up the flocs. A water velocity of 0.1 to 0.5 metres per second is recommended. At this stage the water should not flow over a weir or pour into the water in the settler, as this is likely to break the flocs.

Clarification is achieved in clarifiers, settling tanks or sedimentation tanks. Settling basins are similar but larger structures. In both sedimentation tanks and settling basins, water flows slowly, at around 0.1 to 1.0 centimetres per second, with a retention time of two to four hours. Many larger water treatment plants employ clarifiers in place of sedimentation tanks or settling basins. These clarifiers vary widely in design and operational characteristics. Many are cone-shaped with wide end uppermost. Water enters at the bottom and flows upwards so that its velocity decreases. A loose “blanket” forms in the tank, and clear water rises to the surface where it is taken off by outlets at the surface.

## Jar test

The jar test is a means for deciding whether the dose of coagulant is correct. If too much or not enough coagulant is added, the removal of suspended matter will be less efficient. If too much coagulant is added, the cost of treating the water will also increase. The jar test is carried out as follows :

- Six jars are each filled with 1 litre of raw water from the source used to supply the treatment plant.
- To each jar is added a different dose of coagulant. One jar will have the same dose as that used in the treatment plant. The other jars should have slightly higher or slightly lower doses of coagulant. For example if the normal dose for the treatment plant is 30 milligrams per litre of coagulant, the jars will be dosed as follows :

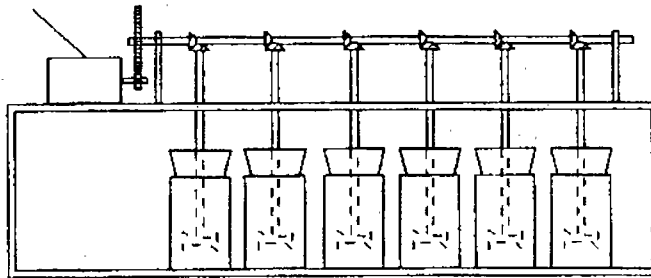
## Fact Sheet 2.13

- The jars are immediately placed in a stirrer with paddles, as shown in Figure 3.

### JAR Dose mg/l

1	26)	— (lower dose)
2	28)	
3	30	— (normal dose used)
4	32)	
5	34)	— (higher dose)
6	36)	

Mechanical Stirrer



**Figure 3. Laboratory stirrer for the jar test**

- The paddles are first operated at high speed (80 rpm) to mix the coagulant with the water thoroughly for one minute.
- Reduce the speed of the paddles to 20 rpm and leave to stir for 30 minutes. This allows the flocs to form.
- Check and record the results of flocculation. Well-coagulated water has well-formed flocs with clear liquid between them.
- Stop the stirrer and leave the samples to settle for 30 minutes.
- Check the settling characteristics. If the water sample is hazy, coagulation has not worked well.
- Record all results in a log book as excellent, good, fair or poor.
- Always try to perform the jar test on water at the same temperature as the water being treated in the plant.

The jar test can only be used as an indication of what is happening in the plant. It is therefore important to observe the plant in operation to see if the dose of coagulant is correct.

There are also other factors which affect coagulation and flocculation, and may be tested for if a laboratory is available : pH and alkalinity.

These two tests can be carried out at the same time as the jar test. Both can change in the raw water and upset coagulation and flocculation. The results of these two tests should be noted regularly in a log book, so that it will be obvious when there are any changes. Both pH and alkalinity of raw water can be adjusted, if necessary, by adding water treatment chemicals.

---

## *Turbidity*

Some plant operators measure the turbidity of the raw water and the dose of coagulant needed at the same time. They then use the results taken over a year or more to plot a graph of turbidity against coagulant dose. This means that a plant operator can decide what dose of coagulant to use simply by measuring the turbidity of the raw water. This is very useful when there are sudden changes in the raw water, for example during heavy rain.





# Rapid sand filtration

Sedimentation with or without coagulation and flocculation will not give adequate water quality. The production of clear water requires the use of a filter.

There are two principal types of filter for community water supply : rapid filters and slow sand filters. Slow sand filters are very efficient in removal of microorganisms from water. They are described in Fact Sheet 2.12. Rapid filters are used primarily to remove turbidity after coagulation and flocculation in large water treatment plants.

Rapid filters can either be open tanks (rapid gravity filters, see Figure 1) or closed tanks (pressure filters, see Figure 2), where water passes through a filter medium, most commonly sand.

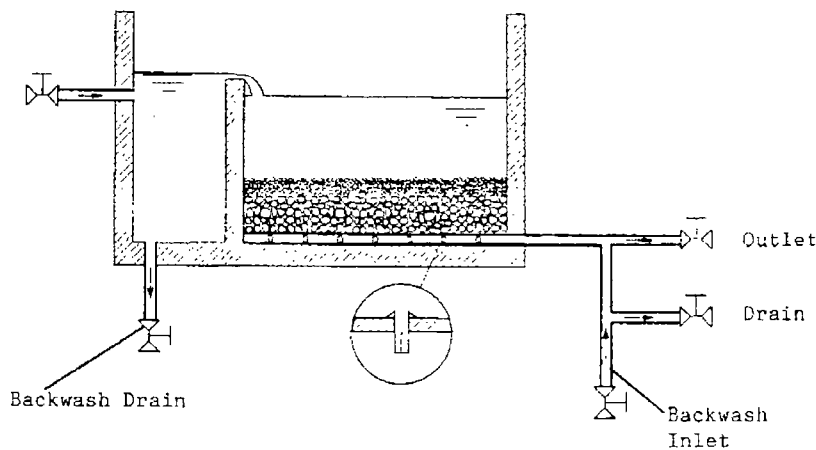


Figure 1. Rapid gravity filter

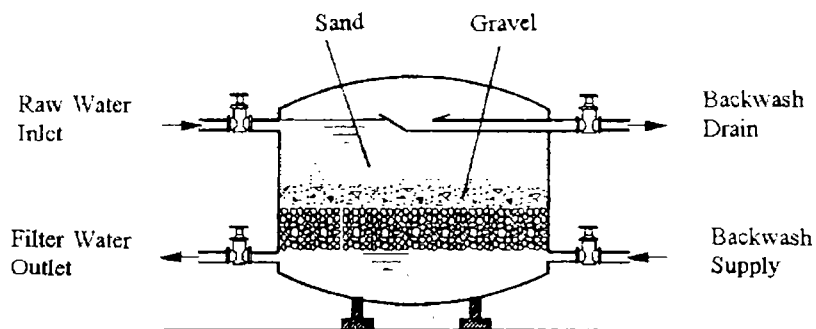


Figure 2. Pressure filter

Water is supplied to the top of a bed of sand, supported on a bed of graded sand and gravel on a system of underdrains. In order to force the water through the sand, a depth of about 1.5 to 2 metres of water must be maintained above the sand. The filtering action of the sand is entirely mechanical and suspended matter is accumulated in the spaces between sand grains until the output of water drops too low. At this point, the filter is drained and cleaned by backwashing.

The necessity for frequent backwashing requires trained staff and frequent checking. However, as rapid gravity filters are compact and efficient, they are very suitable for large installations on restricted sites.

In large urban water supplies, the most commonly used filtration units are rapid gravity sand filters. This process is part of a system which includes coagulation, flocculation, clarification and disinfection.

A well-operated rapid filter will reduce turbidity to less than 1 TU and often less than 0.1 TU. Rapid filtration is not very efficient in removing microorganisms, although some are removed, and should therefore be followed by terminal disinfection.

Backwashing open tank filters generally requires the use of filtered water from a raised storage tank or pumped from the system directly for backwashing purposes. When multiple pressure filters are installed, treated water from one may be used to backwash another. Backwash water is a source of contamination and should not be discharged directly into a river or stream. It is normally discharged into a sewerage system or stabilization ponds. Alternatively, it can be treated and recirculated, if this proves to be cost effective.

---

### *Sanitary inspections of rapid filters*

Sanitary inspections should be conducted regularly to ensure that filters are functioning properly and that an adequate water supply is being maintained (see Fact Sheet 2.1). The key points and observations to make during an inspection are :

- Check the filtration rate through the filter ; this should not exceed the design flow of 5 - 12 metres per hour.
- Check the rate and frequency of backwashing to ensure that the filter is being properly cleaned.
- Check the sand depth to see whether sand is being lost during cleaning.
- Check for mud balls and cracking in the sand bed. If these are found, then the sand may need replacement or backwashing with air and water. Seek expert advice.
- Check outlet turbidity and influent turbidity. There should be over 90 per cent reduction in turbidity.

- Check whether there is sand in the clear water well and gravel on the surface of the filter bed. These indicate problems with the underdrains which will need to be replaced.

---

## *Operation and maintenance of rapid filters*

The operation and maintenance of rapid filters requires some skill, and it should be clear who is responsible for what activities. Maintenance should be regular and planned, in particular the turbidity of treated water and the head loss should be carefully monitored. A complete record should be kept of inlet and outlet water turbidity, head loss and cleaning to ensure that the filter functions efficiently and that an adequate water supply is maintained. The following points cover the key aspects of rapid filters and their operational and maintenance needs.

---

### **Raw water quality**

A rapid filter will not efficiently remove fine suspended solids. It is therefore essential that coagulation and flocculation be performed prior to rapid filtration. Coagulation and flocculation are described in Fact Sheet 2.13.

---

### **Filter medium**

Coarse (effective size 0.5-1.0 millimetre) sand is the most commonly used filter medium in rapid filters. Some filters contain a mixture of sand and larger particles of anthracite (effective size about 1 millimetre). After backwashing, the larger, lighter anthracite particles settle on top of the sand. Water is therefore filtered consecutively through coarse anthracite and then less coarse sand ; this enables longer filter runs between cleaning. The depth of the medium in the filter should be 0.5 to 1.0 metres.

---

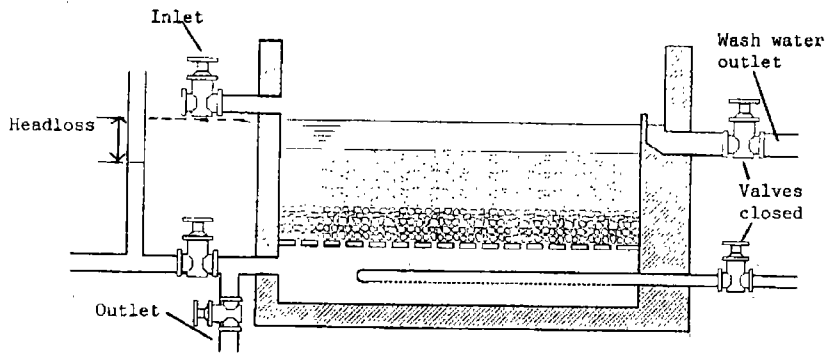
### **Rate of filtration**

Flow rates in rapid filters vary widely ; many installations are designed to operate at a downward water velocity in the filter bed of 4 to 12 metres per hour.

---

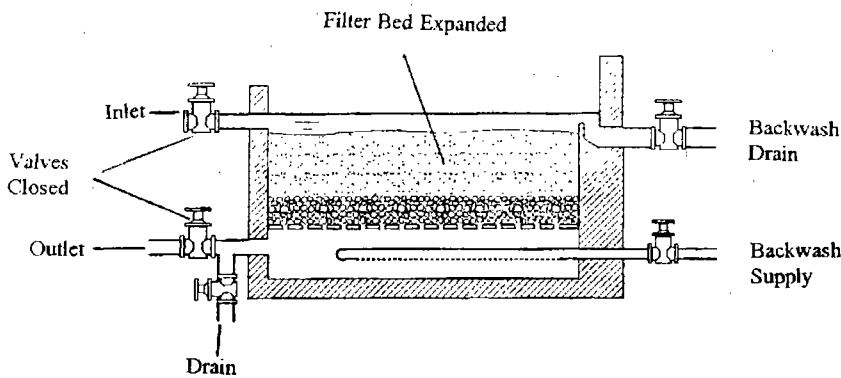
### **Cleaning**

Rapid filters clog fairly quickly because of the high rates of filtration. Typically, they are cleaned every few hours or days. Cleaning may be automatic in large water treatment plants. As the filter operates, it removes suspended matter from the water. Eventually this matter clogs the filter and the flow is reduced. The difference between the level of water above the sand bed and the pressure at the outlet, known as “ head loss ”, will increase (see Figure 3). Cleaning is generally undertaken when the head loss reaches an unacceptable level (for instance 2.5 metres) or when treated water quality deteriorates. This can be readily assessed by regularly monitoring turbidity (see Fact Sheet 2.33). Rapid filters are normally cleaned at regular intervals (every 24 to 72 hours).



**Figure 3. Head loss in a rapid gravity filter**

When a rapid filter needs cleaning, this is done by backwashing. The flow of water is reversed so that treated water is forced up through the filter bed. The sand is re-suspended or “fluidized” in the flow of water but the gravel support layers are undisturbed and the solid matter is separated in the surface wash water. The rate of flow of backwash water must be carefully controlled to make sure that the filter medium (sand) is not washed away. This method of cleaning a rapid sand filter is shown in Figure 4.



**Figure 4. Cleaning a rapid gravity filter**

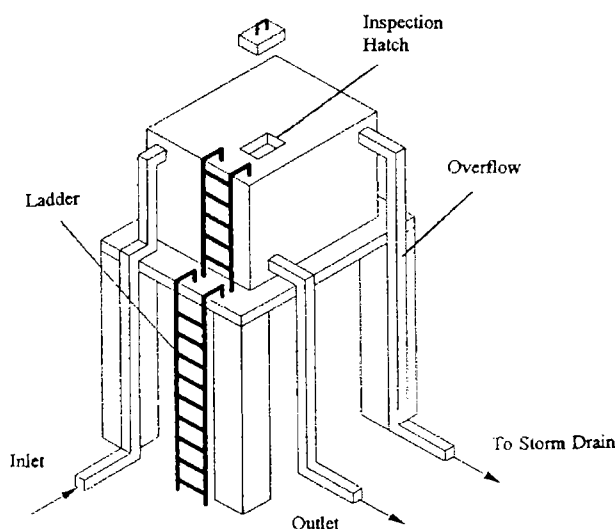
When cleaning is finished (typically after 5 to 10 minutes of backwashing) the backwash flow is stopped and normal flow is resumed. In some systems, cleaning is assisted by injecting air with the backwash water or by mechanical mixing.

# Storage tank

The main function of storage tanks is to smooth out variations in quantity and quality of water in a water supply. This is done by storing water during times when there is little demand, for example at night, and so making sure that there is enough water for peak demand times when many people need water at the same time. Storage tanks should also provide a temporary reserve of water against short term interruptions of supply from the source. The size of the reserve needed will depend on the population to be served, the reliability of the source, and the level of expertise and finance available for water supply maintenance.

Storage tanks are used in most piped networks, and vary in size from small tanks that are part of small gravity water supply systems, to large service reservoirs serving urban water supplies. Storage tanks should be checked, cleaned and disinfected regularly in order to reduce risks of contamination.

Wherever possible, storage tanks should be uphill of the community so that the water will flow through the system by gravity. Where this is not possible the tank can be elevated (see Figure 1) but these tanks are expensive and so are generally smaller.



**Figure 1. An elevated storage tank**

## Sanitary inspections of storage tanks

Regular sanitary inspections of storage tanks and reservoirs should be made to ensure that they remain in good working order and are regularly cleaned (see Fact Sheet 2.1). Sanitary inspections of storage tanks are usually done in conjunction with inspections of the distribution system as a whole. Where large reservoirs are used it may, however, be useful to conduct a separate sanitary inspection for the pipe system. Figure 2 summarizes the key points and observations to make when conducting a sanitary inspection of a storage tank and distribution network.

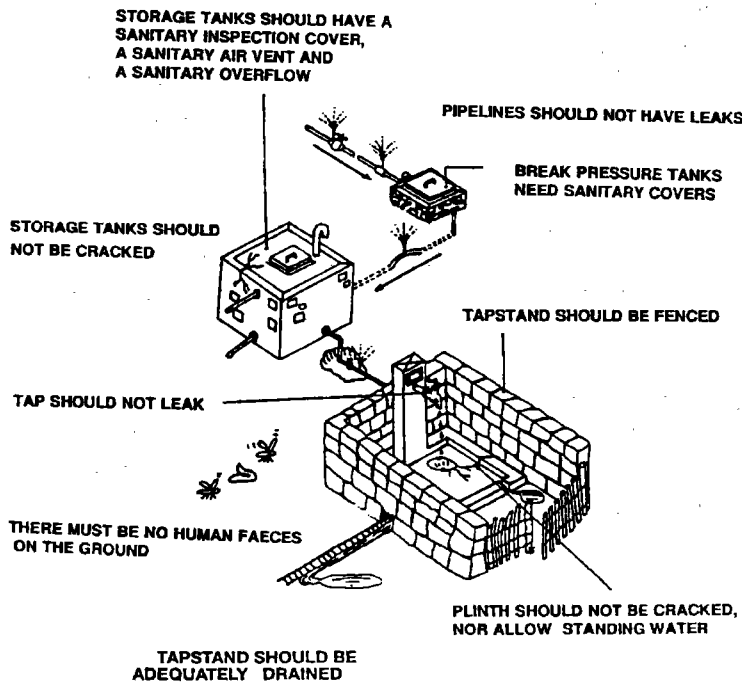


Figure 2. Sanitary inspection of a storage tank and distribution network

## Upgrading of storage tanks

Storage tanks can be upgraded to make cleaning easier and to give better protection to the water stored inside.

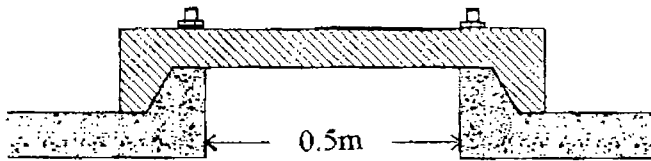
### Cleaning system

Storage tanks should be cleaned and disinfected every six months to remove sediment or other material in the tank (see Fact Sheet 2.26).

---

## Sanitary lid

The sanitary lid has a raised lip which stops rain water washing germs into the storage tank (see Figure 3).



**Figure 3. Sanitary lid**

The sanitary lid should have a chain or bar with a padlock to prevent people from using the water in the tank for washing, as this could contaminate the water for other users. In large tanks or reservoirs, an inspection hatch with a sanitary cover will be required for access. An inspection walkway may also be built inside the tank.

---

## Valves

To protect valves from damage, it is advisable to build a small concrete box with a lid for each valve. The floor of the valve box should be made of earth, to allow any water to soak away into the ground. The lid of the box can be simple but should have a chain or a bar locked with a padlock to stop unauthorised use of the valves. The valves should be greased and checked for damage and rust regularly.

---

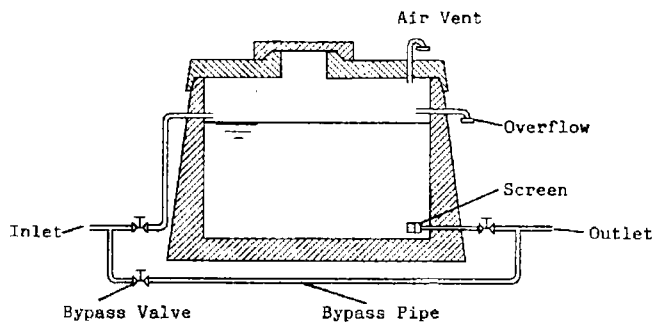
## Overflows and ventilation pipes

All overflows and ventilation pipes must have wire mesh over them, either inside or outside the tank. This is to stop small animals such as mice and bats getting into the storage tank and contaminating the water.

---

## Major repairs

When major repairs to the tank, such as replastering the inside walls and floor, are necessary or cleaning is in progress, a by-pass can be fitted to the tank to allow the water from the source to continue flowing to the community. At peak water use times, there will not be enough water for everyone, but at least basic needs can be met while the tank is being repaired or serviced. A by-pass is shown in Figure 4.



**Figure 4. By-pass system**

When large tanks and service reservoirs are used as part of an urban water supply, they should be made up of two compartments so as to enable supplies to be maintained whilst cleaning and repairs are in progress.

## *Disinfection of storage tanks*

Disinfection of storage tanks is described in Fact Sheet 2.26.



# Disinfectants

Water may be disinfected by physical or chemical means.

Physical disinfectants are treatments, like boiling or irradiation, applied to the water which is then safe to drink. After disinfection, water may be re-contaminated in household handling or storage (see Fact Sheet 2.34).

Some chemical disinfectants (such as chlorine and iodine) remain in the water after application. This residual of disinfectant in water is important because it can minimize bacterial re-growth and the effects of re-contamination. This is one of the reasons why chlorine is a very popular disinfectant for drinking water.

Each disinfectant is available under different trade names and requires specific safety measures, preparation and use. Every disinfectant has advantages and disadvantages.

Filtration may be considered a method of disinfection, but it differs in that bacteria are removed rather than inactivated. Removal of pathogens by filtration may not be complete,

thus filtered water is often also disinfected where this is possible. Filtration at household level is covered in Fact Sheet 2.34. Community water treatment is summarized in Fact Sheets 2.8 to 2.14.

Disinfection should be constant and should not be relied upon as the sole treatment for poor quality water for public distribution. This is because even a short-term fault with disinfection may lead to wide distribution of contaminated water. It is therefore important that disinfection is combined with source protection and, where appropriate, water treatment.

---

## *Selection of disinfectant*

Under most circumstances, overwhelming factors will dictate the selection of disinfection method. The most common major factors are : availability and cost of disinfectant, logistics (especially transport costs), and cost of equipment. In most circumstances, chlorine in one of its forms has been found to be the disinfectant of choice. The choice of which form of chlorine will then largely be determined by the availability and cost of the product, along with transport costs.

Where there is a risk of cholera or an outbreak has occurred, the following chlorine residuals should be maintained :

- At all points in a piped supply 0.5 mg/l
- At standposts and wells 1.0 mg/l
- In tanker trucks, at filling 2.0 mg/l

In areas where there is little risk of a cholera outbreak, there should be a chlorine residual of 0.2 to 0.5 mg/l at all points in the supply. This means that a chlorine residual of about 1 mg/l when water leaves the treatment plant is needed. Chlorine residual can be tasted in water at 0.8 mg/l so, unless higher levels are vital for health reasons, it is recommended that levels above 0.8 mg/l are avoided at points of consumption. If the taste of chlorine is too strong, consumers may reject the water and use an alternative source which, although it may taste better, could be contaminated.

---

## *Chlorine*

Chlorine is an effective disinfectant where water is not turbid (cloudy) and the water to be treated is not alkaline, that is, with a pH not above 8.0. Most natural waters have a pH below 8.0.

As disinfection with chlorine is less effective in turbid water, water to be chlorinated should be clarified. This can be done by natural filtration, as is the case with groundwater from wells and springs, or by filtration during water treatment. Filtration should also remove the cysts and eggs of protozoa and helminths which are resistant to chlorine.

Chlorine persists in water as residual chlorine after dosing. This helps to minimize the effects of re-contamination during storage and distribution. When chlorine is added to water, some of it reacts with substances in the water and is inactivated as a disinfectant (chlorine demand). For this reason, more chlorine than is required will need to be added. This should be taken into account when estimating chlorine requirements. The estimation of requirements for chlorination of water supplies is covered in Fact Sheet 1.8.

Chlorine is easily, rapidly and cheaply measured in water, and this can be done on-site using simple, hand-held colour comparators. Chlorine is available in various forms, including calcium hypochlorite, sodium hypochlorite and as pure chlorine gas in cylinders.

Calcium hypochlorite (chlorinated lime, tropical bleach, bleaching powder, HTH) is a powder containing between 30 and 70 per cent available chlorine. It must be stored carefully to prevent deterioration, and although it can cause burns, is generally safe to handle and transport. The capital (equipment) costs of using calcium hypochlorite for disinfection are generally low. Calcium hypochlorite is most commonly used in solution for the disinfection of rural and small community water supplies and in diffusion hypochlorinators or in tablet form for household use. Technical details regarding calcium hypochlorite are given in Fact Sheet 2.19.

Sodium hypochlorite (including household bleaches) is a solution. Sodium hypochlorite solutions contain about 1 to 18 per cent chlorine and are thus mostly water. The solution must be stored carefully to prevent deterioration, it can cause burns and is inefficient to transport, since it is mostly water. Sodium hypochlorite is most commonly used for disinfection in the home and in water supplies where transport of the solution is not a problem. Technical details of sodium hypochlorite are given in Fact Sheet 2.20.

Pure chlorine gas, in cylinders, is used widely. Specialized transport, handling and dosing equipment are needed. As chlorine in cylinders is not normally subject to deterioration, gas cylinders are an efficient means of storing and dosing chlorine. Leaks of chlorine gas are, however, very dangerous and installations storing cylinders should be well designed, monitored and maintained. Chlorine in cylinders is most commonly used for dosing at water treatment plants, at the head of wells from which water is pumped mechanically, and at re-chlorination plants in large distribution networks. Technical details of chlorine in cylinders are given in Fact Sheet 2.18.

---

## *Chlorine dioxide*

Chlorine dioxide is a more powerful oxidizing agent than chlorine, and its disinfectant action is less pH-dependent than that of chlorine. It leaves a long-lasting residual.

Chlorine dioxide is mainly used for the control of tastes and odours. It does not combine with ammonia to a significant extent and therefore is more efficient than chlorine in waters with raised levels of ammonia.

Chlorine dioxide is unstable and must be generated on-site by the action of chlorine or an acid on sodium chlorite. In general, the two chemicals are dosed together into the water. This process requires constant, vigilant monitoring and control. Chlorine dioxide is much more expensive than chlorine.

---

## *Iodine*

Where water is not turbid, iodine is an effective disinfectant and is more stable than chlorine in storage. Iodine is mostly used for disinfecting small volumes of water for personal use. It is generally too costly for dosing into community water supplies. Iodine reacts less with organic matter than chlorine and does not react with ammonia.

A dose of two drops of a 2 per cent solution of iodine in ethanol per litre of clear water has been recommended for disinfecting small volumes of water for personal use.

For public water supplies, however, 1-2 mg/l with a contact time of not less than 30 minutes is normally recommended. Most people begin to detect the taste and odour of iodine at concentrations in the range 1-2 mg/l.

Iodine in solid form is easy to store and deteriorates less rapidly than chlorine. If dissolved in ethanol, however, iodine will deteriorate rapidly. Stable iodine compounds for dosing into water supply systems, such as tetraglycine potassium tri-iodide, are available as tablets.

Commercial iodine preparations include Globaline, PotableAqua and Individual Water Purification Tablets. Commercial preparations are sold with recommendations concerning dosage and contact time.

Iodine is rarely appropriate as a disinfectant for long-term use in community water supplies, especially because of its cost. Nevertheless, because of its stability and effectiveness, it is very useful for the disinfection of drinking water, especially in small volumes, in emergency or disaster situations.

At high doses (above 4 mg/l), iodine may produce allergic reactions in some individuals and doubts exist regarding the advisability of long-term use of iodine for drinking water disinfection.

---

## *Ozone*

Ozone ( $O_3$ ) is an unstable gas which is only slightly soluble in water. It is an efficient disinfectant, but because it is unstable does not leave a residual in water (unlike chlorine, for example). For this reason it is effectively impossible to over-dose with ozone. Ozone contributes to the bleaching of colour and removal of tastes and odours.

Ozone is produced by passing dry oxygen or air through an electrical discharge. It is manufactured on-site using specialized equipment.

Ozonation is much more expensive than chlorination. It would not normally be considered unless cheap electricity were available and/or chlorination very expensive.

---

## *Ultraviolet radiation*

Ultraviolet (UV) radiation has been used fairly extensively for disinfection of small community water supplies.

The efficiency of UV disinfection is dependent on the intensity and wavelength of the irradiation and the exposure of the microorganisms to the radiation. UV radiation therefore decreases in efficiency as contamination (especially turbidity and some substances in solution, such as iron and organic compounds) increases.

UV disinfection of water is normally achieved by passing the water through tubes lined with UV lamps. This gives efficient disinfection after a contact time of a few seconds. A typical power requirement would be within the range 10-20 W/m<sup>3</sup>h. The UV lamps disinfect using a wavelength of light around 254 nm. The lamps may continue to produce blue light when they are worn out and are no longer producing disinfecting irradiation. The manufacturer's recommendations regarding replacement should be observed.

Disinfection with UV irradiation does not give rise to tastes and odours. There is no requirement for consumable chemicals, maintenance is straightforward and there is no danger of over-dosing. UV irradiation does not leave a residual effect in the water. The equipment and consumables are expensive, and water to be treated must be of consistently high clarity.

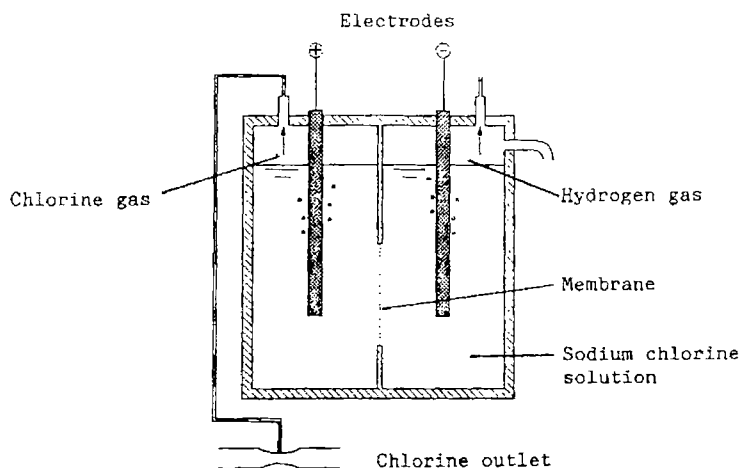
---

## *Mixed oxidizing gases generated on-site*

Since 1982, considerable work has been undertaken, particularly in a number of Latin American countries with the support of the Pan American Health Organization, in the development of mixed oxidizing gases generated on-site for disinfection (MOGGOD).

A MOGGOD device comprises essentially two electrodes separated by a semi-permeable membrane. One electrode is in a saturated solution of sodium chloride. Hydrogen gas is released, which is vented to waste. At the other electrode, a mixed oxidizing gas is produced. The mixture may contain ozone, hydrogen peroxide and chlorine. Whether all of these are produced, and in what proportions, depends on electrode composition, configuration and operating conditions.

In theory, the only consumable items are sodium chloride (salt) and a small amount of electricity. The equipment is still being developed, however, and problems, such as membrane clogging if the salt is not pure, are yet to be overcome. The membranes and electrodes wear out at variable rates which depend on initial quality and operating conditions; their cost is a significant component of the cost of disinfection with MOGGOD. MOGGOD may become useful for small community water supplies. Larger units are not more cost-effective and so MOGGOD is unlikely to be favoured for larger supplies.



**Figure 1. MOGGOD device**

---

## *Boiling and household filters*

Disinfection of water using methods such as boiling or household filters are covered in Fact Sheet 2.34.



# Chlorination concepts

---

## *Inactivation of microbes by chlorine*

Chlorine inactivates all types of microorganisms : protozoa, bacteria and viruses. The rate of inactivation varies widely, but is more rapid when more chlorine is present in the water.

For practical purposes, cysts and eggs of protozoa and helminths may be considered resistant to disinfection with chlorine. They are killed at high doses or after prolonged contact times, but these are often impractical. Cysts and eggs of protozoa and helminths should be removed by filtration prior to disinfection or, in the case of groundwaters (springs and wells), excluded by source protection.

An important advantage of chlorine as a disinfectant is that it remains in the water and continues to protect against the effects of re-contamination. Chlorine remaining in water after disinfection is referred to as chlorine residual.

The efficiency of inactivation of microbes by chlorine is affected by a number of factors including pH, contact time and the reactions of chlorine with the water. These are discussed in the following sections. Nevertheless, microbes may be protected from chlorine if they are attached to or within particles in the water.

For this reason, water to be chlorinated must be clear. It should always have a turbidity of less than five turbidity units and ideally less than one turbidity unit. Methods of water treatment for piped supplies are discussed in Fact Sheet 2.8 and in Fact Sheet 2.29.

---

## *Chlorine in water*

When chlorine is added to water, it is involved in three types of reaction. These affect the availability of chlorine and its efficiency as a disinfectant.

First, substances such as manganese, iron and hydrogen sulphide dissolved in the water will react irreversibly with chlorine. This reaction removes these substances, thereby improving water quality and taste. Chlorine, which reacts in this way is, however, lost and does not contribute to disinfection.

Secondly, chlorine may react reversibly with organic matter and ammonia in water. The compounds formed are weak disinfectants. The products are referred to as combined chlorine or residual combined chlorine.

Thirdly, the chlorine may react with and dissociate in water. The products are efficient disinfectants unless the water is alkaline and are referred to as free chlorine or free residual chlorine.

## Chlorine demand

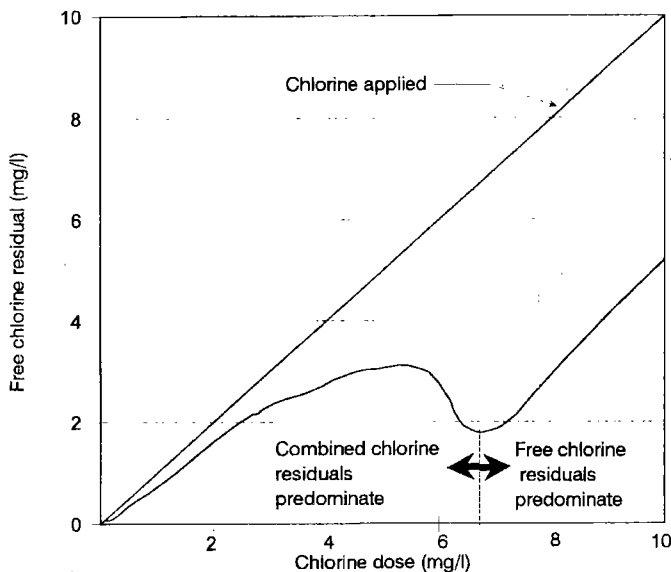
The total amount of chlorine which will react both with compounds like iron and manganese and with organics and ammonia is referred to as the chlorine demand. The chlorine demand of different waters can vary widely.

Chlorine demand is therefore the difference between the amount of chlorine added to the water (the chlorine dose) and the free chlorine detectable in the water.

The chlorine demand for some waters, for instance some river waters, can increase dramatically, particularly after heavy rain. Measurement of chlorine demand is important for control of water treatment processes and is detailed in Fact Sheet 2.31.

## Break-point chlorination

The type of chlorine dosing normally applied to piped water supply systems is referred to as break-point chlorination. Sufficient chlorine is added to satisfy all of the chlorine demand and then sufficient extra chlorine is added for the purposes of disinfection.



**Figure 1. Break-point chlorination**

Figure 1 shows the break-point chlorination curve. It indicates the effect of adding more chlorine to water which contains an initial ammonia nitrogen content of 1 mg/l.

The initial rise in residual is predominantly monochloramine (combined chlorine residual). The subsequent fall with further addition of chlorine is due to the decomposition of monochloramine to form nitrogen (the chlorine detected in this phase is also combined residual).

Finally, the oxidation of ammonia is complete and any additional chlorine will cause an equal increase in the free chlorine residual.



---

## Contact time

Disinfection with chlorine is not instantaneous. Time is required in order for dangerous microbes (pathogens) present in the water to be inactivated.

The time taken for different types of microbes to be killed varies widely. In general, amoebic cysts are very resistant and require most exposure. Bacteria, including free-living *Vibrio cholerae* are rapidly inactivated by free chlorine under normal conditions. For example, a chlorine residual of 1 mg/l after 30 minutes will kill schistosomiasis cercariae, while 2 mg/l after 30 minutes may be required to kill amoebic cysts. Thus it is important to ensure that adequate contact time is available before water enters a distribution system or is collected for use.

Contact time in piped supplies is normally assured by passing the water, after addition of chlorine, into a tank from which it is then abstracted. In small community supplies, this is often the storage reservoir (storage tank). In larger systems, purpose-built tanks with baffles may be used. These have the advantage that they are less prone to "short-cutting" than simple tanks.

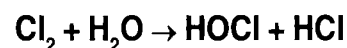
The pH of the water also affects the efficiency of chlorination ; contact time is therefore also related to pH.

---

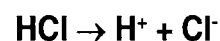
## Chlorine chemistry

Chlorine, whether in the form of pure chlorine gas from a cylinder, sodium hypochlorite or calcium hypochlorite in any of its presentations, dissolves in water to form hypochlorous and hydrochloric acids. Chlorine dioxide, however, does not dissolve in water.

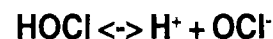
The reaction of chlorine in water follows the reaction shown below :



Hydrochloric acid dissociates in turn to form hydrogen and chloride ions



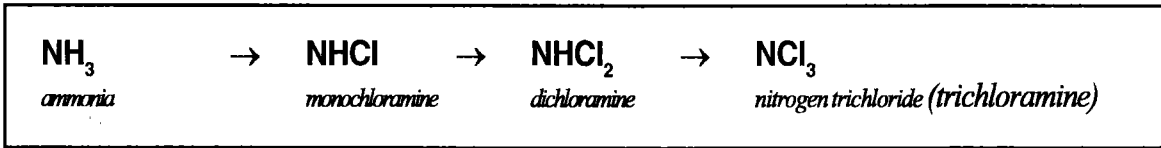
Hypochlorous acid however dissociates only partially



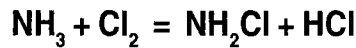
It is undissociated hypochlorous acid which acts as a disinfectant. The equilibrium between undissociated hypochlorous acid, hydrogen ions and hypochlorite ions depends on pH. At high pH (alkaline conditions, pH greater than 8), the dissociated forms predominate and at low pH (acidic conditions) undissociated hypochlorous acid predominates.

For this reason, disinfection with chlorine is more efficient at lower pH values ; a pH of less than 8 is recommended for disinfection. Pure chlorine gas from a cylinder tends to decrease the pH of the water slightly ; hypochlorite tends to

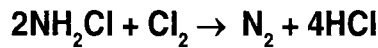
increase water pH a little. Formation of combined chlorine is due to a sequence of reactions. Hydrogen in ammonia is progressively replaced by chlorine as shown below :



Where it is desired to produce monochloramine as a more stable, but less efficient disinfectant, the two chemicals may be dosed in appropriate proportions.



*If a large chlorine dose is applied (relative to ammonia), as is practised in break-point chlorination, then nitrogen is formed :*



## *Chlorine residual*

Chlorine persists in water as residual chlorine after dosing and this helps to minimize the effects of re-contamination by killing or inactivating microbes which may enter the water supply after chlorination. It is important to take this into account when estimating requirements for chlorination in order to ensure that residual chlorine is always present.

The level of chlorine residual required varies with the type of water supply and local conditions. In water supplies which are chlorinated there should always be a minimum of 0.5 mg/l residual chlorine after 30 minutes contact time in water.

Where there is a risk of cholera or an outbreak has occurred, the following chlorine residuals should be maintained :

- At all points in a piped supply 0.5 mg/l
- At standposts and wells 1.0 mg/l
- In tanker trucks, at filling 2.0 mg/l

In areas where there is little risk of a cholera outbreak, there should be a chlorine residual of 0.2 to 0.5 mg/l at all points in the supply. This means that a chlorine residual of about 1 mg/l when water leaves the treatment plant is needed.

---

## *Problems of taste and odour*

The taste of chlorine in drinking water may lead a population to reject a source of water which is actually safe to drink in favour of a better-tasting source of water which may in fact present a greater health risk. Chlorinous tastes in water are most often due to over-dosing or the presence of chlor-phenols.

Over-dosing may be due to error (which should be prevented by proper monitoring and control) ; may be deliberate (for instance, in response to contamination of the supply, which should be corrected as soon as possible and chlorine levels returned to normal) ; or may be due to high-level dosing to ensure adequate concentrations in remote parts of the distribution network (in this case consideration should be given to re-chlorination during distribution).

Chlor-phenols are formed where chlorine reacts with phenolic substances in water. These may be derived from algae, so chlor-phenols are more common in surface waters than in groundwater. Chlor-phenols have a very strong chlorinous taste and very small amounts of chlorine can therefore give rise to very strong tastes. Problems with chlor-phenols are often transient and are best overcome by improving the intake and source.

Although chlorine itself can give rise to problems of taste and odour, chlorination can also help to improve taste and odour by the reduction of organic materials and iron.

---

## *Trihalomethanes*

It is now recognized that chlorine can react with organic substances in some waters to form trihalomethanes (THMs). There is some evidence that trihalomethanes may be uncommon causes of cancer.

Standards for THMs in drinking water vary between 50 and 300 ppb worldwide - the WHO guideline value for chloroform (the most common THM) is 300 ppb. These concentrations are not commonly found in drinking water.

The benefits of reduced infectious disease through the appropriate chlorination of drinking water is generally considered to far outweigh the risk of cancer caused by trihalomethanes. WHO supports the use of chlorine as a disinfectant for drinking water supplies.

---

## *Uses of chlorine*

Chlorine has three major uses in water supply :

- Continuous dosing of piped water supplies at source or as a part of treatment.
- Disinfection of pipes and installations after construction, repair or cleaning.
- Disinfection of water stored in the home.

The latter is especially important where water

is collected or delivered to the home and where epidemic waterborne diseases such as cholera occur.

---

### *Continuous chlorine dosing*

Although residual chlorine in water will help to minimize the effects of re-contamination in distribution pipes, every effort should be made to minimize re-contamination and not to rely on the residual effect.

Continuous chlorine dosing equipment most commonly uses chlorine gas in cylinders, calcium hypochlorite powder, or calcium or sodium hypochlorite solutions as sources of chlorine.

The advantages and disadvantages of various disinfectants are discussed in Fact Sheet 2.16 and their specific technical characteristics in Fact Sheets 2.18 to 2.20.

Continuous chlorine dosing is covered in Fact Sheets 2.21 to 2.24.

Disinfection of pipes and installations is covered in Fact Sheets 2.25 to 2.28.

---

### *Chlorination in the home*

Chlorine residual is readily and rapidly lost, particularly in open or regularly opened storage containers. Good household storage and handling practice are therefore vital to ensure good quality water in the home, and reliance should not be placed on residual disinfectant effect.

Chlorination of water as a means of household water treatment is covered in Fact Sheet 2.34.

## Chlorine gas or liquid in cylinders

Chlorine is a very active chemical which combines directly with many others. Pure chlorine, both as a gas and as a liquid under pressure, reacts with only a few metals at ordinary temperatures. For this reason, chlorine may be safely stored in metal containers. Moist chlorine, however, corrodes most metals rapidly and a solution of chlorine in water has powerful oxidizing, bleaching and germicidal properties. It is therefore of the utmost importance that all containers, pipes and so on used to take chlorine from cylinders should be dry and clean. Glass, ceramics, hard rubbers and some plastics are resistant to moist chlorine.

Liquid chlorine is supplied in steel tanker lorries, cylinders containing 1 ton, and in standard cylinders containing approximately 45 kg or 70 kg at about 5 atmospheres pressure (the actual pressure varies with temperature). Small cylinders containing 5 kg or 9 kg of chlorine are also sometimes seen. Cylinders of 45 kg or 70 kg are sufficient for small water treatment plants with capacities of up to 20 litres per second (approximately 1800 m<sup>3</sup>/day). Cylinders are so filled that the liquid chlorine occupies about 80 per cent of the cylinder at 65°C. Liquid chlorine is stable and no loss of strength occurs during storage. Cylinders must be stored in a cool place.

The small amounts of impurities formed in industrial chlorine can be deposited in flow meter and control valves. Maintenance is therefore required on a regular basis.

Gas or liquid chlorine (liquid chlorine is chlorine gas compressed to a point where it liquefies) is generally suitable only for water supplies in larger communities. For smaller communities and in rural areas either bleaching powder or high-strength hypochlorite materials

are more commonly used, the choice being determined mainly by availability and costs in the particular country or area.

---

### *Installations where chlorine cylinders are stored*

All installations in which chlorine cylinders are stored, handled or used should be specifically designed or adapted for this purpose. It is vital that they are well-ventilated and that air vents are included at floor level. This is because chlorine is heavier than air and sinks.

Persons entering a room in which chlorine gas has accumulated may collapse, thus exposing themselves to the high concentration of gas near the floor. For the same reason, cylinders should not be stored at low points where gas can accumulate.

---

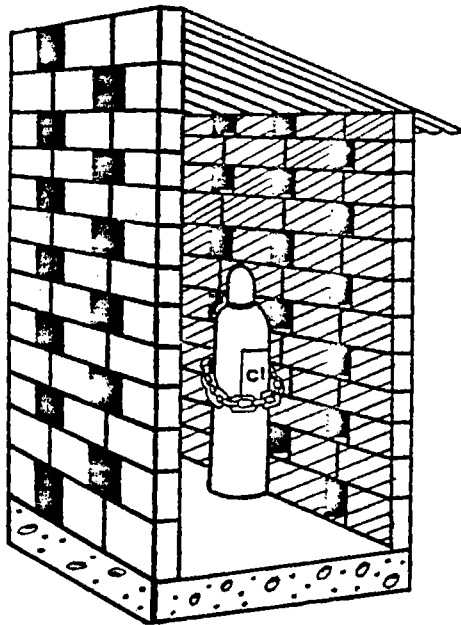
## *Storage of chlorine in cylinders*

Chemicals should be stored in accordance with manufacturers' instructions and local safety regulations. This is both to ensure the safety of the operator and to prevent the chemical from deteriorating.

When issuing chemicals from stock, a careful check must be kept of daily use to ensure that sufficient quantities are available to continue treatment until a new supply is delivered. Replacement supplies should be ordered when stocks held have fallen to pre-determined levels. Stocks should be used in rotation, with the oldest first, to avoid deterioration.

The amount of chlorine in well-constructed cylinders is carefully controlled so that even in the hottest summer conditions there will still be a gas space. If cylinders are imported, they should be checked to ensure that they comply with national standards. It is important that cylinders are not artificially warmed. Cylinders should be stored in a dry place away from combustible materials and risk of fire, if possible on the ground floor and under cover, preferably in an annex, or a separate room not in a main building and not near to an exit from a building.

The protection domes over cylinder valves should not be removed until the cylinders are to be coupled up, as they protect the valves from damage and dirt. When discharging, cylinders should be held in position with a chain. Storage of chlorine in cylinders is shown in Figure 1.



---

**Figure 1. Storing chlorine in cylinders**

---

## *Safety for operators handling chlorine*

The operation and maintenance of equipment for dosing of chlorine from cylinders should only be undertaken by trained and authorized personnel.

Chlorine is a hazardous substance. In solution it is highly corrosive and splashes can cause burns and damage the eyes.

When handling concentrated chlorine solutions, appropriate precautions should be taken. Ideally, gloves and protective eye glasses should be worn. In the event of splashes, and especially splashes to the eyes, it is important immediately to rinse thoroughly with water.

All containers in which chlorine is stored should be labelled, identifying the contents, and with a hazard warning in a form which is readily understood locally.

Storage sites for chlorine in any form should be secure against unauthorized access and especially against children.

---

## *Handling chlorine cylinders*

The following are procedures for safely handling chlorine cylinders. Figure 2 illustrates the safe moving of cylinders.

- Move cylinders with a properly balanced hand truck, with clamp supports that fasten at least two-thirds of the way up the cylinder.
- 45 kg or 70 kg cylinders can be rolled in a vertical position. Avoid lifting these cylinders except with appropriate equipment. Never lift with chains, ropes, slings, or magnetic hoists.
- Always replace the protective cap when moving a cylinder.
- Keep cylinders away from direct heat, for instance steam pipes or radiators.
- Store cylinders in an upright position. All empty chlorine cylinders (depressurized) should be tagged as empty.
- Remove the outlet cap from the cylinder and inspect the threads on the outlet. Cylinders having outlet threads which are corroded, worn, cross-threaded, broken, or missing should be rejected and returned to the supplier.

- Chlorine cylinders should be tested periodically. As an example the specifications and regulations of the United States Interstate Commerce Commission require that chlorine cylinders be tested at 800 psi (5516 kPa or 56.24 kg/sq cm) every five years. The date of testing is stamped on the dome of the cylinder. Cylinders which have not been tested within that period of time should be rejected and returned to the supplier.
- A respirator approved as suitable for the purpose should be worn when opening cylinder valves or other chlorine connections. Canister-type respirators are suitable when performing these routine operations and dealing with small gas leaks. When dealing with a major leak, or if lack of oxygen is suspected, self-contained breathing apparatus must be worn. All operators who may have to use this equipment must be fully trained beforehand.



**Figure 2. Handling chlorine cylinders**



# Calcium hypochlorite

---

## *Different forms of calcium hypochlorite*

Calcium hypochlorite  $\text{Ca}(\text{OCl})_2$  for drinking water disinfection is most commonly encountered as : chlorinated lime or bleaching powder ; high test hypochlorite (HTH) ; or calcium hypochlorite in tablet form.

Chlorinated lime or bleaching powder is a white powder which is a mixture of calcium hydroxide, calcium chloride and calcium hypochlorite. It is variable in quality, that is, in the amount of chlorine which it contains. It typically contains 20 to 35 per cent available chlorine.

High test hypochlorite (HTH) is also a white powder and contains a greater concentration of chlorine than ordinary bleaching powder - typically 65 to 70 per cent. It is also more stable. HTH is sold under a number of proprietary names.

Tablets are made of calcium hypochlorite with added materials to prevent powdering, to stop moisture being absorbed too readily and in some cases to assist dissolving. Tablets are available in various sizes. Small tablets are intended for individual use and contain measured amounts (for instance milligrams) of chlorine suitable for disinfecting, for example, one litre of water. Larger tablets are designed for use in dosing equipment and dissolve at a predictable rate, enabling addition of a measured dose to a water supply. They may also be added to tanks for batch disinfection of large volumes, especially in emergency situations.

The mixture of chlorinated lime and quicklime is known as tropical bleach and is said to be more stable than other forms. It contains 25-30 per cent available chlorine.

All forms of calcium hypochlorite contain a proportion of inert material. This varies from 30-35 per cent in the case of HTH, to 65-80 per cent in the case of bleaching powder.

Where transport or storage costs are high, such costs may represent a significant proportion of total costs.

Calcium hypochlorite is generally unstable and all forms lose potency with time. Chlorine loss may be rapid and is accelerated by light, warmth, humidity and ventilation. HTH is more stable than bleaching powder, although all forms must be properly stored.

---

## *Uses of calcium hypochlorite*

Calcium hypochlorite may be dosed as a solution into a flow of water at a constant rate (see Fact Sheet 2.22). It can be used for disinfecting installations (see Fact Sheets 2.25 to 2.28). It is also used for disinfection of water in batches, typically in disaster situations and for disinfection of water in the home (see Fact Sheet 2.34).

---

## *Storage and handling*

Chemicals should be stored in accordance with manufacturers' instructions and local safety regulations. This is to ensure both the safety of the operator and that the chemical does not deteriorate.

Bleaching powder and HTH are both commonly supplied in sealed plastic bags or in drums or sometimes jars. Individually sealed plastic bags containing a suitable volume for immediate use (for example 1, 2 or 5 kg) are preferable. Calcium hypochlorite will, however, deteriorate even in such bags, and should be stored properly.

All forms of calcium hypochlorite should be stored in a cool, dark, dry place in closed, corrosion-resistant containers (for instance wood, plastic, ceramic, dark glass or cement). In hot climates, containers may burst if not stored correctly.

When stored in a container opened daily for 10 minutes, calcium hypochlorite loses about 5 per cent of its initial available chlorine in 40 days. If left open for 40 days, about 18 per cent loss is suffered.

As with other disinfecting chemicals, stocks should be dated and controlled, and used in rotation to minimize the effects of deterioration.

Calcium hypochlorite which has been stored badly or which may have deteriorated with time may be tested to determine its available chlorine content as described below.

---

## *Making chlorine solutions*

For many disinfection purposes it is necessary to dissolve calcium hypochlorite in water, and the clear chlorine solution produced is used as the disinfectant.

All forms of calcium hypochlorite contain some inert material which is insoluble. This must be separated otherwise it may cause clogging and blockages. In general, therefore, the powder is mixed with water in one tank, left to settle and the clear supernatant decanted off into a storage tank. The preparation of calcium hypochlorite solution is shown in Figure 1.

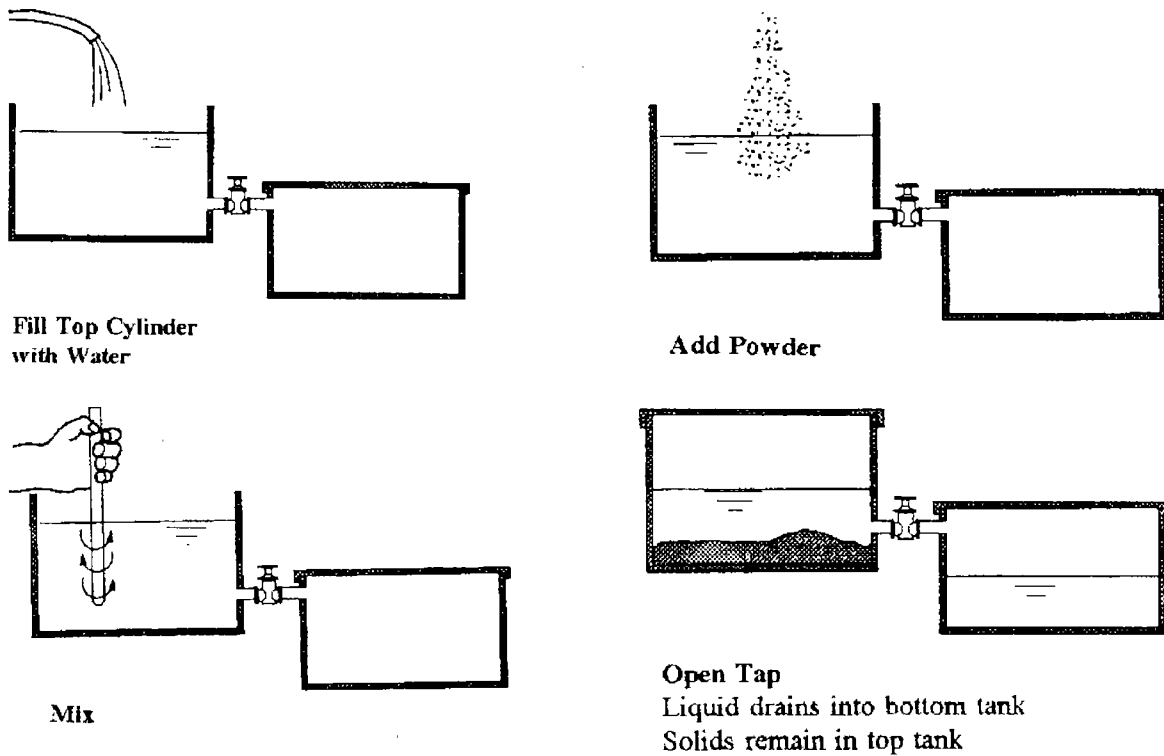


Figure 1. Preparing calcium hypochlorite solution

The concentration of chlorine in solutions, once they are prepared, should not exceed 5 per cent. If it does, then considerable chlorine may be lost in the sediment. The weight of powder to be added to a tank to prepare a chlorine solution of a given strength can be easily calculated, as shown in Box 1.

**Box 1. Calculation of powder weight needed to make up a chlorine solution in a tank**

Weight of powder required,  $W = \frac{1000 \cdot V \cdot C}{S}$  (in grams)

- where :  $V =$  volume of tank in litres ;
- $C =$  concentration of solution required in per cent (percentage by weight available chlorine) ;
- $S =$  strength of powder in per cent weight chlorine.

Example : A solution of concentration 0.5% (5 grams available chlorine per 1 litre water) is to be prepared, using a tank of 80 litres volume and a powder with a strength of 20% weight chlorine.

Weight of powder required,  $W = \frac{1000 \cdot 80 \cdot 0.5}{20}$  ; therefore,  $W = 2000$  grams.

\* \* \*

A volume,  $v$ , of this solution of concentration 0.5 % (500 mg/l) can be diluted into a new volume of water  $V_1$  to give new solution of concentration  $C_1$  :  $C_1 = \frac{v \cdot C}{V_1}$

Example : 2 ml of the 0.5% solution is added to 1 litre of water. The concentration of the newsolution will be :

$$C_1 = \frac{2 \text{ ml} \cdot 0.5}{1000 \text{ ml}} = 0.001\% = 10 \text{ mg/l}$$

Chlorine solutions are less stable than calcium hypochlorite in powder form. They can be stored for several weeks but may deteriorate rapidly. The same general precautions used for storing powders should be applied. It is especially important that the solution is protected from light in a closed container.

Preparing a chlorine solution from powder for disinfection of water in the home is described in Fact Sheet 2.34.

---

## *Safety*

Chlorine is a hazardous substance. In solution it is highly corrosive and splashes can cause burns and damage the eyes.

When handling concentrated chlorine solutions, appropriate precautions should be taken. Ideally, gloves and protective eye glasses should be worn. In the event of splashes and especially splashes to the eyes, it is important immediately to rinse thoroughly with water.

When a disinfecting agent has to be transported under difficult conditions (for instance on foot), then solid forms (rather than hypochlorite solutions or pure chlorine in cylinders) are advantageous because they are less hazardous to handle. Although solid forms are generally less hazardous to handle, it is good practice to wash hands after handling.

All containers in which chlorine is stored should be labelled, identifying the contents, and with a hazard warning in a form which is readily understood locally.

Storage sites for chlorine in any form should be secure against unauthorized access and especially against children.

---

## *Available chlorine*

The potency of the various forms of presentation of calcium hypochlorite is expressed as available chlorine. Available chlorine is expressed as a percentage. For instance, a bleaching powder may have 25 per cent available chlorine, that is, 25 parts by weight of chlorine per 100 parts by weight of bleaching powder.

It is important to be able to assess the potency of calcium hypochlorite powders. This is especially useful for comparing potential sources of supply, and in assessing the deterioration of powders in storage. Available chlorine can be estimated simply if basic laboratory equipment is available (see Box 2).

**Box 2. Assessing calcium hypochlorite solutions**

A representative sample of the powder is taken (or several samples), mixed thoroughly and a small amount (say 1 gram) is accurately weighed. This is dissolved in distilled water to produce a solution of less than 5 per cent available chlorine (for example 1 gram of bleaching powder of about 25 per cent available chlorine dissolved in 1 litre of water, will give a solution of about 0.25 per cent chlorine). This is then diluted in distilled water to within the range of chlorine measurement (depending on the equipment and method used) and the concentration of chlorine accurately determined. The percentage of available chlorine in the original powder may then be calculated.

# Sodium hypochlorite

---

## *Forms of sodium hypochlorite*

Sodium hypochlorite is available as solutions of varying strength. Concentrated solutions for disinfection purposes may contain 10 to 18 per cent available chlorine ; domestic and laundry bleaches typically contain 3 to 5 per cent available chlorine ; antiseptic solutions may contain only about 1 per cent chlorine.

Sodium hypochlorite for disinfection is commonly sold in drums, often of 25 litres. A large proportion of the weight of sodium hypochlorite when purchased is water. For this reason it is rarely economical unless other forms of chlorine (such as calcium hypochlorite powder) are unavailable or transport is short and not problematical.

Sodium hypochlorite may sometimes be available as an unwanted by-product of the chemical industry.

---

## *Uses of sodium hypochlorite*

Sodium hypochlorite solution may be dosed into a flow of water at a constant rate (see Fact Sheet 2.22). It can be used for disinfecting installations (see Fact Sheets 2.21 to 2.28). It can also be used for disinfection of water in batches, typically in disaster situations and for disinfection of water in the home (see Fact Sheet 2.34).

---

## *Storage and handling of sodium hypochlorite*

Chemicals should be stored in accordance with manufacturers' instructions and local safety regulations. This is to ensure both the safety of the operator and that the chemical does not deteriorate.

Deterioration of sodium hypochlorite solutions may be rapid and is accelerated by light, heat and ventilation. Solutions should be stored in a cool, dark place in closed, corrosion-resistant containers (for instance plastic, ceramic, dark glass or cement).

When diluted with hard water, sodium hypochlorite may react with salts and form a precipitate. In some areas, sodium hexametaphosphate is added to hypochlorite to prevent the formation of such a precipitate. Under very cold conditions, freezing of hypochlorite solutions may occur.

As with other disinfecting chemicals, stocks should be dated and controlled, and used in rotation to minimize the effects of deterioration.

Sodium hypochlorite which has been stored badly or which may have deteriorated with time may be tested to determine its available chlorine content as described below.

## *Safety*

Sodium hypochlorite is a hazardous substance. In solution it is highly corrosive and splashes can cause burns and damage the eyes.

When handling concentrated sodium hypochlorite solutions, appropriate precautions should be taken. Ideally, gloves and protective eye glasses should be worn.

In the event of splashes and especially splashes to the eyes it is important immediately to rinse thoroughly with water.

When a disinfecting agent has to be transported under difficult conditions (for example on foot) then solid forms (rather than hypochlorite solutions or pure chlorine in cylinders) are advantageous and are less hazardous to handle.

All containers in which sodium hypochlorite is stored should be labelled, identifying the contents, and with a hazard warning in a form which is readily understood locally.

Storage sites for sodium hypochlorite in any form should be secure against unauthorized access and especially against children.

## *Available chlorine*

The potency of the various forms of sodium hypochlorite is expressed as available chlorine. Available chlorine is expressed as a percentage ; for example, a bleaching powder may have 15 per cent available chlorine, that is 15 parts by weight of chlorine per 100 parts by weight of concentrated solution.

It is important to be able to assess the potency of sodium hypochlorite solutions. This is especially useful for comparing potential sources of supply, and in assessing the deterioration of solutions in storage. Available chlorine can be estimated simply if basic laboratory equipment is available, as described in the box.

### **Assessing sodium hypochlorite solutions**

The solution is mixed and a small volume (say 1 ml) accurately measured and diluted in distilled water. Stepwise dilutions are made to bring the concentration of chlorine to within the range of chlorine measurement (depending on the equipment and method used) and the concentration of chlorine is accurately determined. The percentage of available chlorine in the original powder may then be calculated.

For example :

- Add 1 ml of bleach solution to 99 ml of distilled water (a 1/100 dilution) ;
- Add 1 ml of this (1/100 dilution) to 99 ml of distilled water (a 1/10,000 dilution) ;
- Add 1 ml of this (1/10,000 dilution) to 99 ml of distilled water (a 1/100,000 dilution) ;
- The chlorine in this (1/100,000 dilution) is accurately determined as 1.6 mg/litre ;
- The chlorine concentration in the bleach solution was :  
 $1.6 \text{ mg/litre} \times 100,000 = 160,000 \text{ mg/litre} = 160 \text{ g/litre} = 16 \text{ g/100 ml} = 16\%$ .

## Continuous chlorination of dug wells

Dug wells include open wells, dug wells fitted with a lid and bucket, and dug wells fitted with a handpump.

Groundwater is water which can be reached by using a well. It is generally of good microbiological quality. This is because the water has had to filter through surface layers of soil and most bacteria, viruses and parasites will have been removed.

Building a well increases the risk of contamination of groundwater because it provides a direct link between contamination on the surface and the water below. It is therefore important that the installations be given a proper sanitary finishing. Sanitary aspects of dug wells are covered in Fact Sheet 2.2.

As the risk of contamination of well water is high, it is important that sound sanitary precautions are in place and that the water is chlorinated. Chlorination will help to maintain the high quality of the water in the well and to minimize the effects of recontamination after collection, during transport and household storage.

---

### *Methods of chlorinating simple wells*

There are two principal methods for dosing chlorine into simple wells : diffusion hypochlorinators ; and repeated (for example, daily) additions of hypochlorite solution. In both methods, it is preferable for a local person both to undertake routine monitoring and to be responsible for dosing.

---

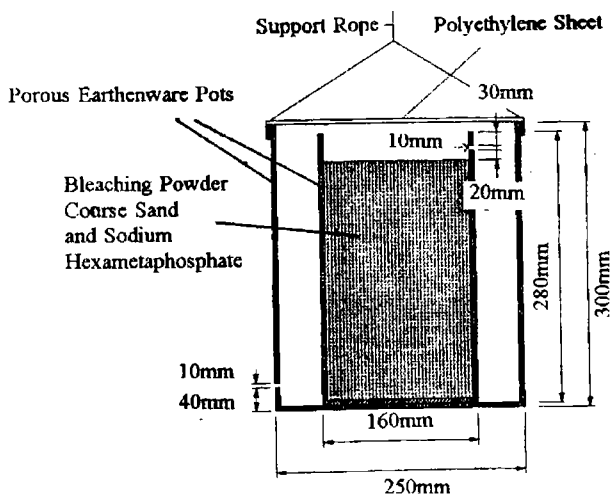
### *Diffusion hypochlorinators*

A number of simple devices have been devised, which are filled with calcium hypochlorite powder and lowered into wells. There, they slowly release the hypochlorite into the water and so disinfect it.

The effectiveness of these devices varies, depending partly on local conditions and practices. If continuous disinfection of wells with diffusion hypochlorinators is considered, then a preliminary evaluation is needed to select an appropriate technology.

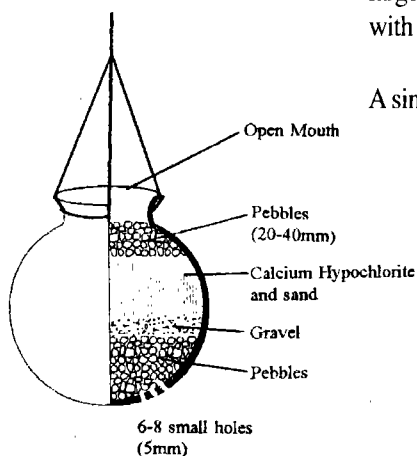
One model, referred to as a double pot chlorinator, is illustrated in Figure 1.





**Figure 1. Double pot chlorinator**

In the double pot chlorinator, each pot has one hole, that of the smaller pot near the top and that of the larger pot near the bottom. A moistened mixture of one kilogram of bleaching powder, two kilograms of coarse sand (two to three millimetres) and 75 grams of sodium hexametaphosphate is added to the inner pot to a level just below the hole. The smaller pot is placed in the centre of the larger pot with the two holes on opposite sides. The larger pot is then covered with a polythene sheet and the unit lowered carefully into the well.



A similar device, known as a porous pot chlorinator is illustrated in Figure 2.

**Figure 2. Porous pot chlorinator**

Porous pot chlorinators can be made from plastic or ceramic material and typically have a capacity of seven to ten litres. Holes drilled into the base of the pot are required if the pot is not porous.

*When starting disinfection of a well for the first time with a diffusion hypochlorinator, it should be remembered that the water may have a chlorine demand and this may at first use up the dissolving hypochlorite. It is preferable to add hypochlorite solution (usually 5 per cent) until residual free chlorine can be detected, before positioning the hypochlorinator for the first time.*

It is important that regular and frequent monitoring of chlorine concentrations is undertaken after dosing. A record of chlorine used, results of monitoring, and adjustments made should be kept. Similarly, a record of adjustments and repairs to equipment should be maintained.

The sodium hexametaphosphate added to the mixture reduces caking and helps prevent calcium hypochlorite reacting with hardness salts in the water to form calcium carbonate. When this occurs, the chlorine outlet openings tend to block with precipitate. If sodium hexametaphosphate is not added to the mixture then the hypochlorinator will be less efficient and special care should be taken with cleaning when re-filling.

The rope or cable used to suspend the chlorinator in the well should be checked each time it is removed and replaced whenever necessary.

---

## *Repeated addition of chlorine*

It is often possible to maintain an acceptable chlorine residual in wells by daily or twice-daily additions of hypochlorite solution.

The objective should be to ensure that the free chlorine residual is always within an acceptable range - for instance 0.2-1.0 mg/l. A level of 0.2 mg/l may generally be taken as a minimum, whilst concentrations above about 1 mg/l (depending on temperature) may make consumers reject the water because of the taste of chlorine.

The most straightforward procedure is to measure the volume of the water in the well (see Box 1) and then calculate the amount of chlorine solution needed to dose 1 mg/l to the water (see Box 2).

- Add the solution and wait for the chlorine to react (about 20 minutes), then measure the free chlorine residual.
- If there is no residual, add a further similar dose, leave it to react and then measure the free residual.
- Repeat this as many times as necessary.
- Once a free chlorine residual is detected, calculate and then add the dose of chlorine needed to raise the free residual concentration to the top of the chosen range (say, 1 mg/l).
- Thereafter, make daily or twice-daily measurements.
- Each time, calculate the amount of chlorine solution needed to raise the free residual concentration to the top of the chosen range (say, 1 mg/l) and add this amount (see Box 3).

Experience has shown that the measurement and addition of hypochlorite may often be successfully undertaken by members of the local community, if they are provided with initial training and occasional but regular supervision. Box 1. Estimating the volume of water in a well

### Box 1. Estimating the volume of water in a well

Measure the diameter of the well in metres = D ;

Measure the depth of water in the well in metres = W ;

Calculate the area of the well,  $A = \frac{D^2 \times 3.14}{4}$  (in square metres)

Volume of the water =  $A \times W$  cubic metres

Example : A well 1.2 metres diameter with 3 metres depth of water.

$$\text{Area} = \frac{1.2^2 \times 3.14}{4} = 1.13 \text{ m}^2$$

$$\text{Volume} = 1.13 \times 3 = 3.39 \text{ m}^3$$

### Box 2. Calculating the amount of chlorine needed to add 1 mg/l of chlorine to the well

Volume of stock solution (litres to be added) =  $\frac{\text{volume of water in well (m}^3\text{)}}{\% \text{ Cl in stock solution} \times 10}$

Example : A well containing 9.5 m<sup>3</sup> water stock solution of 1% chlorine.

$$\text{Volume to be added (litres)} = \frac{9.5}{1.0 \times 10} = 0.95 \text{ l}$$

### Box 3. Calculating the amount of chlorine needed to raise the concentration of chlorine

Volume of stock chlorine to be added (litres) =  $\frac{\text{increase needed (mg/l)} \times \text{volume of water}}{\% \text{ Cl in stock solution} \times 10}$

The increase needed is the difference between the free chlorine residual concentration and the concentration required. For example, if the free chlorine residual is 0.3 mg/l and the target is 1.0 mg/l, then the increase needed is 0.7 mg/l.

Example : A well with 9.5 m<sup>3</sup> of water has 0.3 mg/l chlorine residual and 1.0 mg/l residual is required. The stock solution is 1% chlorine.

$$\text{Increase needed} = 1.0 - 0.3 = 0.7 \text{ mg/l}$$

$$\text{Volume to be added} = \frac{0.7 \times 9.5}{1.0 \times 10} = 0.665 \text{ litres} = 665 \text{ ml}$$

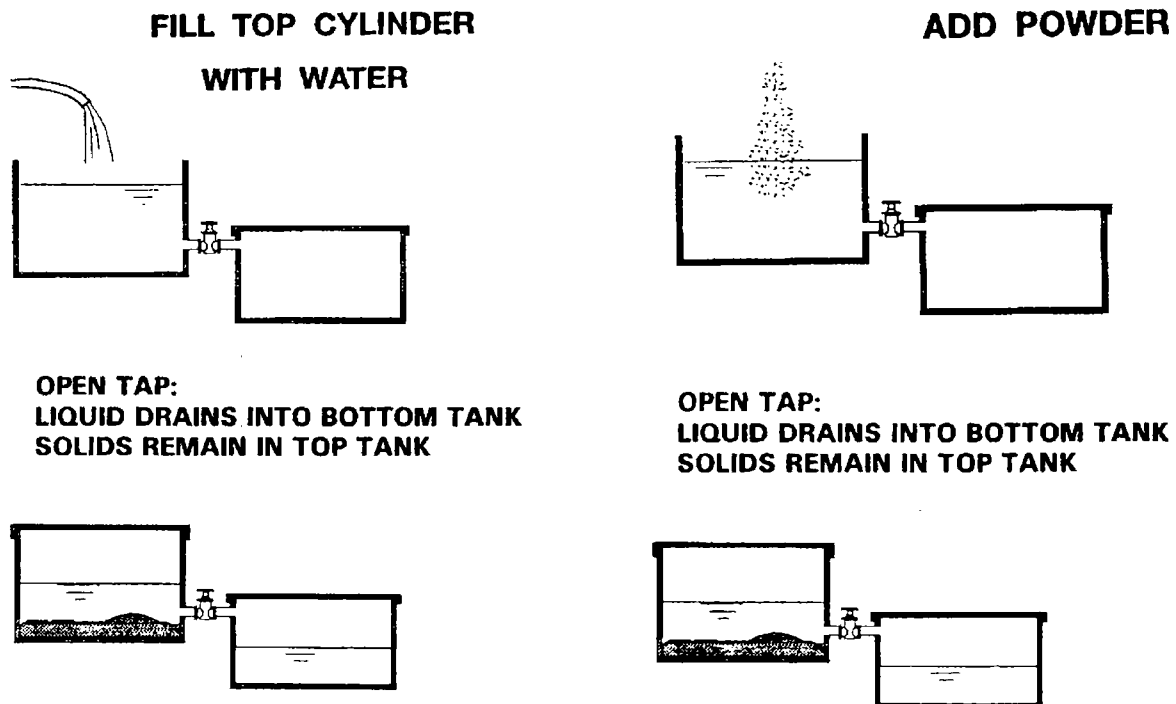
# Dosing hypochlorite solutions

Most systems for hypochlorite solution dosing comprise three major components :

- Solution preparation ;
- Flow control ;
- Application.

The concentration of the hypochlorite solution is not strictly controlled, so chlorine levels should be monitored at the point of use and adjustments made at the site of flow control. The preparation of solution is simple using sodium hydroxide, as sodium hydroxide is available as a solution which can be diluted to an appropriate concentration (two per cent available chlorine).

Calcium hypochlorite preparations, however, contain some inert material and it is important that the solution is prepared and allowed to settle, before the clear solution is decanted off for use.



**Figure 1. Preparation of calcium hypochlorite**

Storage, handling and preparation of calcium hypochlorite is detailed in Fact Sheet 2.19 and of sodium hypochlorite in Fact Sheet 2.20.

Flow control mechanisms vary widely. Many may be constructed from readily available materials and are not costly. The most important types are described below.

Application of hypochlorite solutions should be at a point of turbulence to ensure adequate mixing. It should also be as early as possible in the supply system (except that chlorine should generally be added after other treatment and should never be added before slow sand filters) in order to ensure adequate contact time. Ideally, chlorinated water will flow into a contact tank, which will ensure a residence time of at least one hour, before the water enters the distribution network. In many small supplies this is provided by the storage tank or reservoir. However, this may be prone to short-cutting, especially if the inlet and outlet are positioned close to one another.

---

### *Operation and maintenance of dosing equipment*

It is important to ensure regular monitoring of chlorine concentration after dosing, in piped distribution networks, and at distant points. Equipment should be adjusted as required and a record made of chlorine used. Results of monitoring and records of adjustments and repairs to equipment should be maintained.

Where solutions are made up from calcium hypochlorite powder, two tanks should be used (see Fact Sheet 2.19). The make-up tank, where the solution is mixed, should be cleaned regularly removing the white precipitate to prevent it being carried over into the next operation.

In general, the solution will be prepared in the make-up tank one day, left to settle overnight, and sedimented into the solution tank the next day. If this is not possible, the solution must be left for a minimum of one hour before decanting. The amount of solution in the solution tank should be checked regularly to ensure that solution can be made up when required. Generally, solution tanks hold sufficient hypochlorite to last a few days (often two to four days).

Where “dropping” equipment is used (for instance, drip-feed dosers), the dropping equipment should be regularly inspected for precipitates or blockages. Where pumps are used, they should be operated and maintained in accordance with the manufacturers’ instructions.

It is important that all installations where chlorine is stored and handled are secure, especially against children. Site security should be periodically checked.

## Drip-feed chlorinators

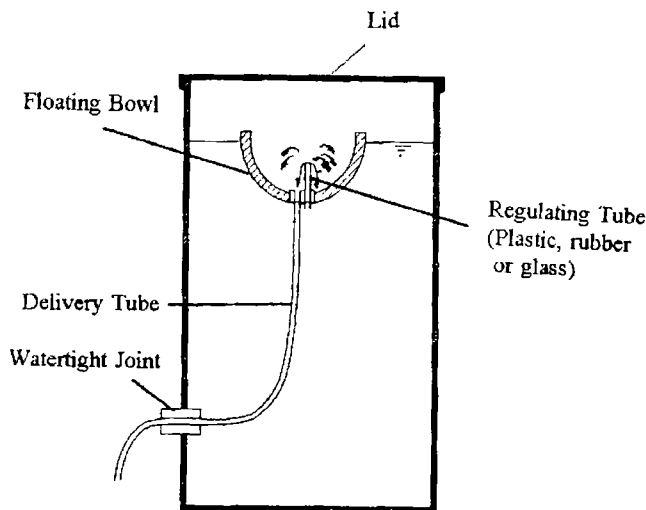
Drip-feed chlorinators are most used for small community water supplies. They feed a constant rate of drops of chlorine into the flow of water. The flow of water is assumed to be constant and therefore the chlorine dose will be constant.

If a pipe were connected to the chlorine tank and allowed to drip slowly directly into the flow of water, then the rate of drops would slow down as the level in the chlorine tank lowered. For this reason a constant head device is needed.

A simple constant head device is shown in Figure 2. The flow of chlorine solution out of the outlet tube is unrestricted; what controls the rate is the depth of the inlet to the tube below the surface of the chlorine solution and this is constant no matter what the depth of chlorine solution in the tank. In order to prevent siphoning, the dosing pipe is open at both ends and should be of ample bore.

This type of system can be adjusted to supply as little as a few tens of litres per day. The solution outlet is the top of the tube leading into the floating bowl (see Figure 2).

By lowering the outlet the dosing rate is increased and by raising the outlet the dosing rate is decreased. The depth of the outlet below the surface of the chlorine solution may be adjusted by moving the tube up or down or by using weights, such as stones, to force the whole float to sit lower in the hypochlorite solution.



**Figure 2. A constant head device for drip-feed chlorination**

It is important to check hoses and tubes on drip-feed chlorinators regularly for blocking. They should be cleaned at regular intervals and replaced when necessary.

## Constant-head aspirator (Mariotte Jar)

This is the simplest device for dosing hypochlorite solution and, given basic care, it can prove reliable in operation over many years.

The aspirator is fitted with a right-angled capillary outlet and a centre tube air inlet. When it is filled and solution drops from the capillary, air is drawn down the centre tube and bubbles up into the air space. The centre tube is full of air and is at atmospheric pressure at the base. Thus the head across the capillary is independent of the level in the aspirator, and can be altered (thus altering the drip rate) by rotating the capillary between horizontal and vertical positions.

Such a drip feeder can readily be assembled from standard laboratory glassware (the bottle must be rigid) and quickly installed. It requires minimal protection from the weather but must be kept completely dark. A 20-litre aspirator is a useful size for many situations, and is reasonably easily handled. The capillary bore most suitable for maintaining a trouble-free drip is 0.7-1.0 mm and the centre tube, preferably of medium to thick-walled glass, should have a diameter of 10-15 mm.

Coarse adjustment of drip rate is made by altering the height of the centre tube. For low flows (five drops per minute, or about one litre per day, is a practical minimum), it is preferable to have the capillary outlet less than 45° from the horizontal to preclude crystallization and subsequent blocking. Ten per cent sodium hypochlorite crystallizes only in the coldest weather. The equipment should ideally be installed in an insulated hut. Figure 3 shows a constant-head aspirator.

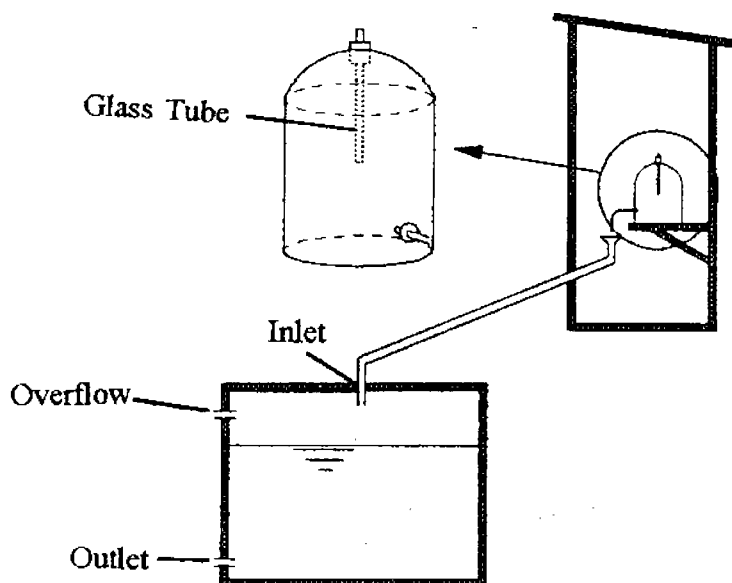


Figure 3. Constant - head aspirator

A plastic tube can be used to deliver hypochlorite to the dosing point, which should be above a point of turbulence. The tube should be laid with a continuous downward gradient to prevent choking and should run inside a metal tube if there is a risk of rodent attack.

Spare glass tubes should be kept on site, and rubber bungs should be changed every two years. The operator should understand the principle of the doser so that she or he will take the necessary care when recharging. The solution should be topped up to the foot of the neck and the bung pressed gently into position to avoid spillage. The foot of the centre tube should be repositioned if necessary. It may be necessary to remove sediment periodically, to avoid blockage of the capillary. The aspirator must then be rinsed with scrupulous care.

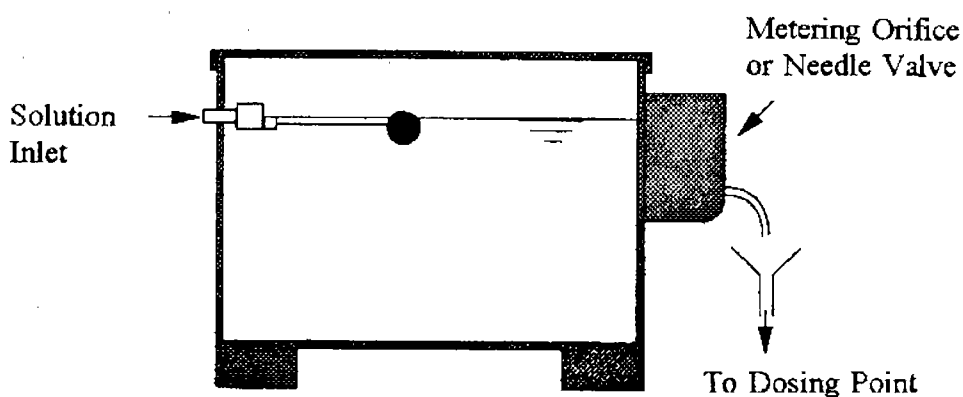
After recharging, the capillary should be set to the vertical position and left to drip until the centre tube becomes full of air and bubbles into the aspirator. The capillary should then be rotated into the position to give the required dose rate, which should be checked.

---

### *Gravity solution feeder*

This is a proprietary design, available in a range of sizes. The principle is similar to the floating draw-off system, except that the constant head is maintained in a second tank by a ball valve.

Solutions can be dosed at rates from 22 litres to 44 cubic metres per day. A gravity solution feeder is shown in Figure 4.



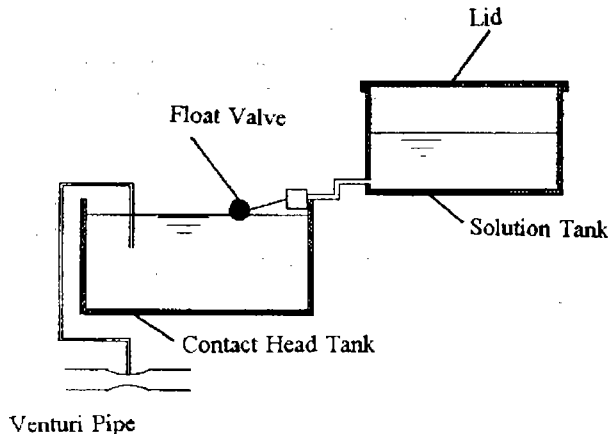

---

**Figure 4. Gravity solution feeder**



## Venturi systems

Provided adequate hydraulic head is available, then the suction generated by a venturi (essentially a contraction in a pipe through which water flows) can be used to draw hypochlorite solution into a flow of water. Flow rate will be related to the head through which the solution must be drawn, so a constant head tank will be required. An illustration of this system is shown in Figure 5.



**Figure 5. Venturi doser**

## Dosing pumps

A variety of dosing pumps exist, including self powered, water-powered, diaphragm displacement and electrical dosing pumps.

All hydraulic pumps require an adequate head of water with which to operate. The manufacturer's instructions for installation should always be followed. While some pumps are specifically designed for dosing of disinfectant solutions, others have been designed primarily for other purposes. Some, for example, are primarily designed for dosing agricultural chemicals into irrigation water.

Several types of electrical pumps are available and may be either mains or battery operated. Under some circumstances, battery operation from batteries recharged from a solar, wind or water powered generator may be preferred.

Reciprocating pumps are the most commonly used pumps for chemical dosing. They should be constructed from corrosion-resistant material. They can be of a piston or diaphragm type and can have both manual and automatic adjustment of stroke length and rate. The stroke length of the pump controls the dosing level and the stroke rate the dosing rate.

All dosing pumps require the following conditions to function properly :

- They should be sited in an accessible place with space and light for attention and repair.
- They should be securely mounted, and have short and direct runs.

- They should receive regular maintenance checks, and repairs should be made when necessary.
- A sufficient stock of essential spares should be held.
- There should be a properly trained and supported operator.

Some key factors influencing the use of dosing pumps are the following :

- Equipment should, if possible, dose the chemical as delivered. Dosing range is from about 1 ml/h to 5 l/h, although it should not be expected that any single unit would cover the whole range.
- Electrical supply voltage and frequencies vary from country to country, and pump motors must comply with local requirements. Units are also available which are designed to operate from 12V DC batteries.
- Preferred units should have : simple operating principles, simple and robust construction of liquid contact parts, few and slow-moving working parts, minimal sliding friction, positive mechanical drive (for example, crank) to the displacer, diaphragm-sealed pumping chamber, small unswept volume, two vertical-flow valves in series on both suction and delivery, ball valves on soft seats, access to valves without opening pumping chamber, design that provides ease of cleaning and replacement of renewable parts, adequate technical information, good after-sales service, ease of replacement, spare parts or similar units readily available.
- Adjustment of effective stroke length is acceptable from full stroke down to 25 per cent. Control of stroke rate is acceptable from 1 to 150 strokes per minute.
- Preference should be given to systems in which the hypochlorite solution container operates at pipeline pressure, provided that it can be refilled easily and that there is clear visual indication of the amount of hypochlorite remaining in stock.

## Dosing chlorine for cylinders

---

### *Safety for operators handling chlorine*

**Chlorine is a hazardous substance. In solution it is highly corrosive and splashes can cause burns and damage the eyes.**

When handling concentrated chlorine solutions, appropriate precautions should be taken. Gloves should be worn and protective eye glasses are essential.

In the event of splashes and especially splashes to the eyes it is important immediately to rinse thoroughly with water.

All containers in which chlorine is stored should be labelled, identifying the contents and with a hazard warning in a form that is readily understood locally.

Storage sites for chlorine in any form should be secured against unauthorized access and especially against children

---

### *Vacuum-type gas chlorinators*

A chlorine leak would be a hazard to equipment, to personnel and potentially to the public. In order to minimize the risk of and consequences of such a leak, the vacuum-type system has been developed.

A part of the water to be chlorinated is passed through an injector, either under its own pressure or via a booster pump. The injector is in essence a venturi (that is, a waisted section of pipe). Where the water passes through the constriction, its pressure falls below that of the atmosphere. At this point a smaller pipe is connected which runs to the chlorine cylinder and which therefore is subject to a vacuum. Should a leakage occur, it is more likely that air will be drawn into the system, diluting the chlorine, rather than chlorine escaping to cause damage and create a health risk.

A vacuum gas chlorinator is illustrated schematically in Figure 1

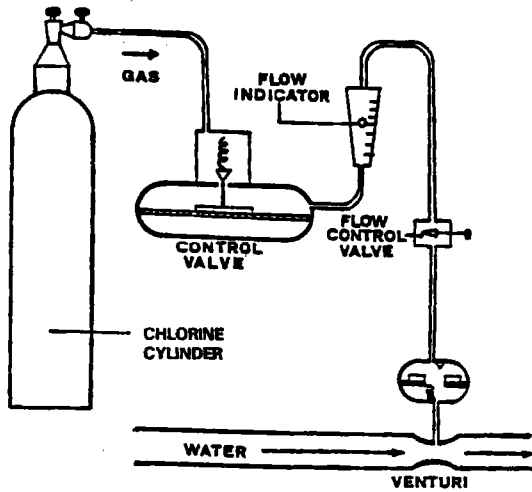


Figure 1. Vacuum gas chlorinator

As a safety measure, the system incorporates a check valve. In order for chlorine gas to flow, the vacuum must be sufficiently strong to overcome the spring in this check valve. If the vacuum is broken or severely reduced, then the check valve will stop the flow of chlorine gas. This spring is so set as to give a controlled constant pressure to the flow meter and control valve. A flow control valve and flow meter are incorporated in the system to enable monitoring and control of the supply of gas.

This system is suitable where chlorine demand does not vary much from day to day and where the water is either flowing at a steady rate or not at all, for instance from a borehole. It has the advantage that gas is delivered into the pipe under conditions which favour rapid dissolution.

Chlorinators used for dosing chlorine should be sized to match the hourly flow to be dosed. This is calculated by :

$$\text{chlorine flow} = \text{water flow} \times \text{chlorine dose}$$

**g/h**
**m<sup>3</sup>/h**
**mg/l**

Some standard capacities of tanks and tare weights are shown in the table below. The last column indicates the range of daily flows which the chlorine contained in the cylinder could dose at 1 mg/l with a cylinder change every three months at the lower flow and every seven days at the higher flow.

**Chlorine cylinders**

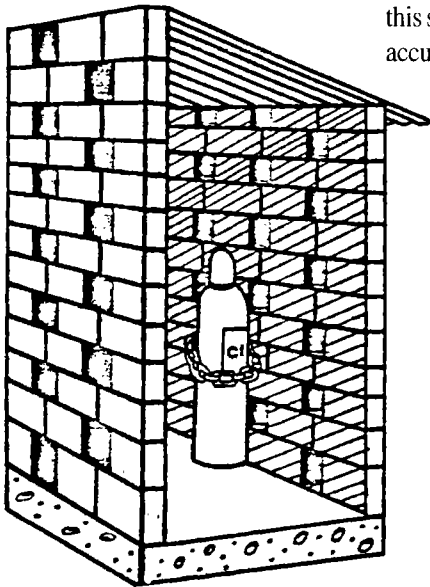
Minimal chlorine capacity (kg)	Typical tare weight of cylinders (kg)	Range of daily water flow dosed at 1 mg/l (m <sup>3</sup> /day)	
		Lower flow (3 months)	Higher flow (7 days)
71	70		100 000
43	40		60 000
33	35		50 000
4.5	9		650
1.5	5		200

Gas chlorination is generally not recommended for supplies of under ten cubic metres per day.

## *Installations where chlorine cylinders are stored*

All installations in which chlorine cylinders are stored, handled or used should be specifically designed or adapted for this purpose. It is vital that they are well-ventilated and that air vents are included at floor level. This is because chlorine is heavier than air and sinks.

Persons entering a room in which chlorine gas has accumulated may collapse, thus exposing themselves to the high concentration of gas near the floor. For this same reason, cylinders should not be stored at low points where gas can accumulate. Figure 2 shows the correct way to store chlorine cylinders.



**Figure 2. Storing chlorine cylinders**

## *Operation and maintenance*

Operation and maintenance of equipment for dosing of chlorine from cylinders should only be undertaken by fully trained and authorized personnel ; details are not provided here. In general, the following should be in place :

- A system for training and authorizing personnel to operate equipment of this type. No unauthorized personnel should be allowed to perform these tasks.
- Guidelines for operation and maintenance in written form, accessible to all staff expected to perform these tasks.
- A record of chlorine levels post-treatment and in distribution, and adjustments made.

When carrying out maintenance work on chlorine dosing equipment, make sure that safety equipment is ready before entering the chlorine area. Always carry out work on chlorine dosing equipment with someone watching you work in case of an accident. During maintenance, the following should be checked :

- Check to see if the cylinder needs changing.
- Check that all lines and equipment are clean.
- When connecting a new cylinder, always fit new gaskets. Spare gaskets should be kept in a dark, cool place to prevent deterioration.
- When a new cylinder is connected, open the valve slowly and check for leaks. Never leave the valve partially open for longer than one minute or it may block up. Open the valve fully as soon as you have checked for leaks.
- Adjust the chlorine flow rate according to the results of testing for chlorine residual (see Fact Sheet 2.17) in treated water leaving the plant.
- If “frost” appears on the valves or connections, there is a risk that chlorine may re-liquefy. The liquid chlorine may then block the supply line. Extreme care should be taken under these circumstances because if the liquid re-evaporates it can create sufficient pressure to cause the remaining chlorine to shoot out of a disconnected supply line. “Freezing” tends to occur when removal rates of chlorine are too high.
- Lubricate equipment if necessary.
- Keep a log of leaks, change of cylinders, repairs to equipment and lubrication of equipment.

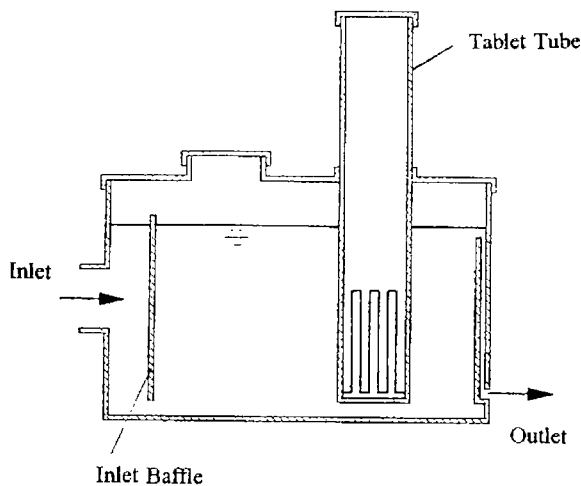
---

### *When dosing equipment is not operating adequately*

It is essential to be wearing protective clothing before repairing leaks in chlorine gas dosing equipment. It is possible to test for the site of a leak by using ammonia, if this is available. Soak a rag on the end of a stick in ammonia and hold it next to the pipes, cylinder and dosing equipment. A white cloud will show the site of a leak.

## Hypochlorite tablet dosers

The simplest form of tablet chlorinator, shown in Figure 1, consists of a rectangular plastic container with an inlet baffle to spread the inflow across its width and a vertical slot at the other end forming the outflow. The container lid is pierced to take a vertical tube, slotted at the lower end, which stands on the floor of the container and holds a stack of tablets. Water flowing through the chamber dissolves the tablets. As this arrangement, if applied directly to the full flow, produces much higher dose rates than would normally be required, a by-pass system is needed to allow only a controlled proportion of flow to pass through the doser. This by-pass is the only control of dosing in a tablet doser ; the unit itself is not adjustable.



**Figure 1. Simple tablet chlorinator**

Most box chlorinators are capable of a minimum dose of about 60 mg/l chlorine per minute and are therefore not appropriate for water flows of less than 3.6 m<sup>3</sup>/hour.

### *Operation and maintenance*

Hypochlorite tablet dosers are often purchased from the suppliers of the tablets themselves. The manufacturers' guidelines regarding operation and maintenance should be followed. In general this will require :

- Regular, frequent topping up of the tablet reservoir.
- Regular, but less frequent, cleaning out of the apparatus and lines of accumulated precipitates, scale, and such like.
- Regular frequent monitoring of residual chlorine in the distribution network, and adjustment of the dose control on the vertical tube and by-pass system accordingly.

## Cleaning and disinfection of wells

---

### *Why is it important to clean and disinfect a well ?*

When a well is sunk or upgraded, some contamination almost always gets into it. This contamination comes from the soil, from animals such as rats and mice, from water used for washing sand and gravel, and from the feet or boots of the workers who are sinking or improving the well. It is important to kill any germs which are in the installation before it is used by the community.

Germs from latrines or animal excreta may seep into the soil and get into a well even though the well is a long way away. In some cases, it is difficult to find out where the contamination is coming from, and the germs have to be killed by putting disinfectant into the well every day. If contamination is very serious and cannot be improved, provided that there is an alternative source, the well may have to be abandoned.

---

### *Making up a chlorine solution*

There are various ways of disinfecting wells, but the most common is to use chlorine. The two forms of chlorine suitable for disinfecting wells are calcium hypochlorite and sodium hypochlorite. These are described in Fact Sheets 2.19 and 2.20.

Normally, a 0.2 per cent solution of chlorine should be made up using either sodium hypochlorite (liquid bleach) or calcium hypochlorite (HTH).

---

### *Safety for operators handling chlorine*

The operation and maintenance of equipment for dosing of chlorine from cylinders should only be undertaken by trained and authorized personnel.

*Chlorine is a hazardous substance. In solution it is highly corrosive and splashes can cause burns and damage the eyes.*

When handling concentrated chlorine solutions, appropriate precautions should be taken. Ideally, gloves and protective eye glasses should be worn. In the event of splashes and especially splashes to the eyes, it is important immediately to rinse thoroughly with water.

All containers in which chlorine is stored should be labelled, identifying the contents, and with a hazard warning in a form which is readily understood locally.

Storage sites for chlorine in any form should be secure against unauthorized access and especially against children.



## *Sodium hypochlorite or liquid bleach*

Liquid bleach is normally bought in bottles or sachets. Check that the contents are sodium hypochlorite and water only. The normal concentration of chlorine in liquid bleach is five per cent, but this may be lower if the bottle has been opened or stored for a long time (Fact Sheet 2.20 gives further details). Make up the solution as described in Box 1.

### **Box 1. Using sodium hypochlorite (liquid bleach) to make a chlorine solution**

- Fill three plastic buckets with clean water to about 5 cm from the top to allow for the bleach to be added. Most commercially available buckets hold 12.5 litres, but the quantity of water should be checked.
- Add enough liquid bleach to each bucket to make up a 0.2 per cent solution of chlorine.

Example : Capacity of bucket, 12.5 litres water = 12500 millilitres.

Need 0.2% or 0.2 grams of chlorine per 100 millilitres of water,

therefore  $\frac{12500 \text{ ml}}{100 \text{ ml}} \times 0.2 \text{ grams} = 25 \text{ grams}$  chlorine is needed per bucket.

Liquid bleach is assumed to contain 4% or 4 grams of chlorine per 100 millilitres,

therefore  $\frac{25 \text{ grams}}{4 \text{ grams}} \times 100 \text{ millilitres} = 6.25 \times 100 \text{ millilitres} = 625 \text{ millilitres}$  of liquid bleach must be added to 12.5 litres of water to make a 0.2 per cent solution of chlorine.

So, 625 millilitres of liquid bleach must be added to each bucket of water.

- Mix the water and bleach well, before use.

## *Calcium hypochlorite or HTH*

Calcium hypochlorite or high test hypochlorite (HTH or HTHC) comes as white granules and can often be bought from a local ministry of health office or from commercial warehouses and pharmacies. Calcium hypochlorite is much stronger than liquid bleach and does not lose strength so quickly. Calcium hypochlorite comes in various forms which can have from 20 to 70 per cent chlorine. Fact Sheet 2.19 covers calcium hypochlorite in more detail.

The best type of calcium hypochlorite to use is high test hypochlorite (HTH or HTHC), as this normally contains 50 to 70 per cent chlorine. Always check with the supplier or on the side of the container to be sure of the percentage chlorine content. Make the chlorine solution as described in Box 2.

**Box 2. Using calcium hypochlorite to make a chlorine solution**

- Fill three plastic buckets with clean water to about 5 cm from the top to allow for the calcium hypochlorite to be added. Most commercially available buckets hold 12.5 litres, but the quantity of water should be checked.
- Add enough calcium hypochlorite to each bucket to make up a 0.2 per cent solution of chlorine.

Example : Capacity of bucket, 12.5 litres water = 12500 millilitres.

Need 0.2% or 0.2 grams of chlorine per 100 millilitres of water,

therefore  $\frac{12500 \text{ ml}}{100 \text{ ml}} \times 0.2 \text{ grams} = 25 \text{ grams}$  chlorine is needed per bucket.

If calcium hypochlorite contains 50% chlorine or 50 grams of chlorine per 100 grams of powder, then 25 grams (the amount of chlorine needed per bucket) is contained in

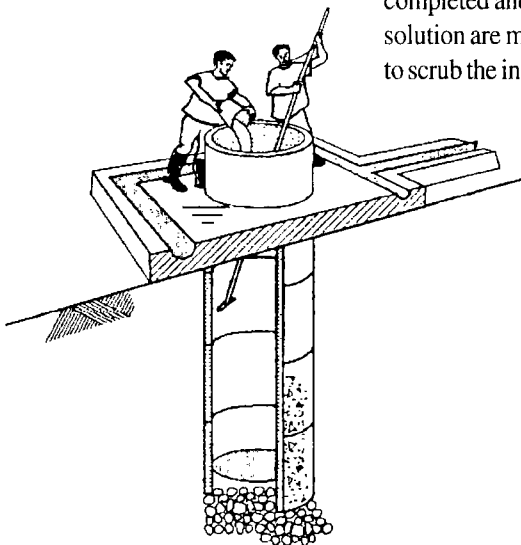
$\frac{25 \times 100 \text{ grams}}{50} = 50 \text{ grams}$  of powder.

Therefore, 50 grams calcium hypochlorite must be added to 12.5 litres of water to make a 0.2 per cent solution of chlorine. So, 50 grams of calcium hypochlorite should be added to each bucket of water.

- Mix the water and calcium hypochlorite well and leave to dissolve for an hour. Some white sediment will sink to the bottom of the bucket ; only the clear liquid should be used to disinfect the well and the sediment should be thrown away.

*Disinfection of a dug well*

All dug wells should be thoroughly cleaned and disinfected once they are completed and before they are used. Three buckets of 0.2 per cent chlorine solution are made up as described above. A brush on a long handle is then used to scrub the inside walls of the well with the solution (see Figure 1).



**Figure 1. Disinfection of a dug well**

After the walls of the well have been scrubbed, pour the remaining chlorine solution into the well. Mix up three more buckets of chlorine solution and pour them also directly into the well. If the well has a pump, then the outside of the rising main should be scrubbed and the pump operated to allow chlorine to enter the pump. The well should be left for 24 hours. A bacteriological test should be done to check that the water is safe to drink after disinfection. If the results show continued contamination, the well should be disinfected again.

After 24 hours, the well can be used as normal. If there is a pump, then pump water to waste until the smell and taste of chlorine is acceptable to the users. Where there is no pump, water should be withdrawn and thrown away until the users are satisfied with the taste and smell. If the smell and taste of chlorine is very strong and persists, then the water may be left to stand in a covered container for several hours until the taste is acceptable.

Many wells are disinfected only once, after which they continue to provide a safe water supply. In many areas, however, the aquifers are contaminated, and protecting a groundwater source no longer guarantees safe water. In these circumstances, regular or continuous disinfection will be required to produce adequate quality water. Generally, hypochlorite is the preferred disinfectant as it is safer and easy to use. The method of disinfection is likely to be either by diffusion hypochlorinator or by continuous addition of hypochlorite. These are covered in more detail in Fact Sheet 2.21.

---

## *Boreholes*

The procedure for cleaning and disinfecting boreholes is very similar to that of dug wells. Make up two buckets of 0.2 per cent chlorine solution and pour these down the borehole. Operate the pump until the water pumped out starts to smell of chlorine, then leave the borehole overnight. It may be a good idea to chain and padlock the pump to stop people using it while the chlorine is working.

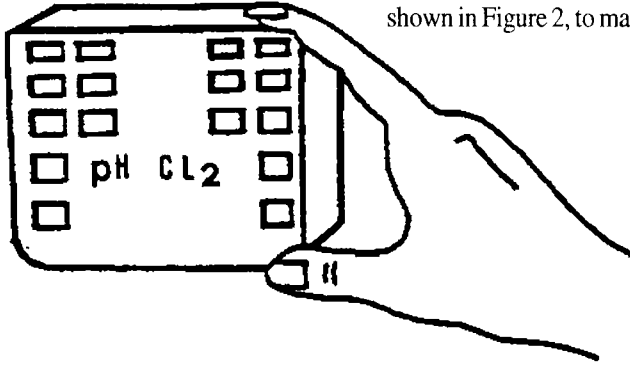
In the morning, operate the pump until the water no longer smells strongly of chlorine. If possible, check the level of chlorine in the water using a chlorine tester, as shown in Figure 2.

Some boreholes operated with mechanical or electrical pumps are connected to pipe distribution networks and the water is continuously disinfected using chlorine dosing from cylinders. This is covered in more detail in Fact Sheet 2.23. Where the borehole is fitted with a handpump or supplies a small community piped supply with a storage tank, then any continuous disinfection is more likely to be by the addition of hypochlorite either directly into the borehole or into the tank. The disinfection of storage tanks is covered in more detail in Fact Sheet 2.26.

---

## Testing for bacteria

All wells and boreholes should be tested for contamination with faecal indicator bacteria every six months. If the results show contamination of the well, it should be continuously disinfected with chlorine solution. The level of chlorine in the well should be checked every morning using a pocket tester, like the one shown in Figure 2, to make sure that there is enough chlorine to kill the germs.



---

Figure 2. Pocket chlorine tester

## **Cleaning and disinfection of storage tanks**

---

### *Why is it important to clean and disinfect a storage tank ?*

It is important to clean and disinfect storage tanks regularly (for example, every 6 months) or after any rehabilitation or maintenance work. A storage tank may be contaminated from animals such as rats, the feet or boots of workers, sedimented materials, etc. Therefore it is imperative that it is cleaned and disinfected recurrently, according to the risks of contamination brought about by lack of appropriate tank protection, lack of effective water disinfection practices, etc.

---

### *Making up a chlorine solution*

The two forms of chlorine suitable for disinfecting wells are calcium hypochlorite and sodium hypochlorite. These are described in Fact Sheets 2.19 and 2.20.

Normally, a 0.2 per cent solution of chlorine should be made up using either sodium hypochlorite (liquid bleach) or calcium hypochlorite (HTH).

---

### *Safety for operators handling chlorine*

The operation and maintenance of equipment for dosing of chlorine from cylinders should only be undertaken by trained and authorized personnel.

Chlorine is a hazardous substance. In solution it is highly corrosive and splashes can cause burns and damage the eyes.

When handling concentrated chlorine solutions, appropriate precautions should be taken. Ideally, gloves and protective eye glasses should be worn. In the event of splashes and especially splashes to the eyes, it is important immediately to rinse thoroughly with water.

All containers in which chlorine is stored should be labelled, identifying the contents, and with a hazard warning in a form which is readily understood locally.

Storage sites for chlorine in any form should be secure against unauthorized access and especially against children.

## *Sodium hypochlorite or liquid bleach*

Liquid bleach is normally bought in bottles or sachets. Check that the contents are sodium hypochlorite and water only. The normal concentration of chlorine in liquid bleach is five per cent, but this may be lower if the bottle has been opened or stored for a long time (Fact Sheet 2.20 gives further details). Make up the solution as described in Box 1.

### **Box 1. Using sodium hypochlorite (liquid bleach) to make a chlorine solution**

- Fill three plastic buckets with clean water to about 5 cm from the top to allow for the bleach to be added. Most commercially available buckets hold 12.5 litres, but the quantity of water should be checked.
- Add enough liquid bleach to each bucket to make up a 0.2 per cent solution of chlorine.

Example : Capacity of bucket, 12.5 litres water = 12500 millilitres.

Need 0.2% or 0.2 grams of chlorine per 100 millilitres of water,

therefore  $\frac{12500 \text{ ml}}{100 \text{ ml}} \times 0.2 \text{ grams} = 25 \text{ grams}$  chlorine is needed per bucket.

Liquid bleach is assumed to contain 4% or 4 grams of chlorine per 100 millilitres,

therefore  $\frac{25 \text{ grams}}{4 \text{ grams}} \times 100 \text{ millilitres} = 6.25 \times 100 \text{ millilitres} = 625 \text{ millilitres}$  of  
4 grams liquid bleach must be added  
to 12.5 litres of water to make  
a 0.2 per cent solution of chlorine.

So, 625 millilitres of liquid bleach must be added to each bucket of water.

- Mix the water and bleach well, before use.

## *Calcium hypochlorite or HTH*

Calcium hypochlorite or high test hypochlorite (HTH or HTHC) comes as white granules and can often be bought from a local ministry of health office or from commercial warehouses and pharmacies. Calcium hypochlorite is much stronger than liquid bleach and does not lose strength so quickly. Calcium hypochlorite comes in various forms which can have from 20 to 70 per cent chlorine. Fact Sheet 2.19 covers calcium hypochlorite in more detail.

The best type of calcium hypochlorite to use is high test hypochlorite (HTH or HTHC), as this normally contains 50 to 70 per cent chlorine. Always check with the supplier or on the side of the container to be sure of the percentage chlorine content. Make the chlorine solution as described in Box 2.

**Box 2. Using calcium hypochlorite to make a chlorine solution**

- Fill three plastic buckets with clean water to about 5 cm from the top to allow for the calcium hypochlorite to be added. Most commercially available buckets hold 12.5 litres, but the quantity of water should be checked.
- Add enough calcium hypochlorite to each bucket to make up a 0.2 per cent solution of chlorine.

Example : Capacity of bucket, 12.5 litres water = 12500 millilitres.

Need 0.2% or 0.2 grams of chlorine per 100 millilitres of water,

therefore  $\frac{12500 \text{ ml}}{100 \text{ ml}} \times 0.2 \text{ grams} = 25 \text{ grams chlorine is needed per bucket.}$

If calcium hypochlorite contains 50% chlorine or 50 grams of chlorine per 100 grams of powder, then 25 grams (the amount of chlorine needed per bucket) is contained in

$\frac{25 \times 100 \text{ grams}}{50} = 50 \text{ grams of powder.}$

Therefore, 50 grams calcium hypochlorite must be added to 12.5 litres of water to make a 0.2 per cent solution of chlorine.

So, 50 grams of calcium hypochlorite should be added to each bucket of water.

- Mix the water and calcium hypochlorite well and leave to dissolve for an hour. Some white sediment will sink to the bottom of the bucket ; only the clear liquid should be used to disinfect the tank and the sediment should be thrown away.

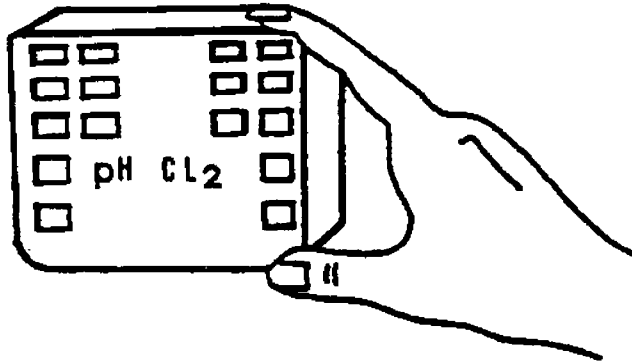
## *Storage tanks*

When the tank is ready to go back into service, the disinfected water should be drained and the tank flushed with clean water to reduce the chlorine residual to below 1 mg/l. The chlorine content of the clean water should be checked and water only allowed to flow into the pipe network once an acceptable chlorine residual is reached.

---

## *Testing for bacteria*

All storage tanks should be tested for contamination with bacteria every six months. If, some days after disinfection, a storage tank still has high levels of contamination, it may need to be continuously chlorinated by adding a small amount of chlorine solution every day. The level of chlorine in the tank should be checked every morning using a pocket tester (as shown in Figure 1) to make sure that there is enough chlorine to kill the germs.



---

**Figure 1. Pocket chlorine tester**



# Cleaning and disinfection of pipelines

---

## *Why is it important to disinfect pipelines ?*

When a pipeline is laid or upgraded, some contamination almost always gets into the pipes from the soil, mud and water in the trench, and from the feet or boots of the workers who are laying or repairing the pipeline. It is important to kill any germs which are in the pipeline before it supplies water to the community.

Where the source of water is a spring, germs from latrines or animal excreta sometimes seep into the soil and get into the spring, even though it may be a long way from these sources of contamination. In these cases, it is difficult to find out where the contamination is coming from and the germs have to be killed by putting disinfectant into the spring every day. Whatever the source of water for a piped system, the water may need continuous treatment and disinfection in order to provide a safe drinking water supply.

---

## *Making up a chlorine solution*

There are various ways of disinfecting pipelines, but the most common is to use chlorine. The two forms of chlorine suitable for disinfecting pipelines are calcium hypochlorite and sodium hypochlorite. These are described in Fact Sheets 2.19 and 2.20.

Normally, a 0.2 per cent solution of chlorine should be made up using either sodium hypochlorite (liquid bleach) or calcium hypochlorite (HTH).

---

## *Safety for operators handling chlorine*

The operation and maintenance of equipment for dosing of chlorine from cylinders should only be undertaken by trained and authorized personnel.

Chlorine is a hazardous substance. In solution it is highly corrosive and splashes can cause burns and damage the eyes.

When handling concentrated chlorine solutions, appropriate precautions should be taken. Ideally, gloves and protective eye glasses should be worn. In the event of splashes and especially splashes to the eyes, it is important immediately to rinse thoroughly with water.

All containers in which chlorine is stored should be labelled, identifying the contents, and with a hazard warning in a form which is readily understood locally.

Storage sites for chlorine in any form should be secure against unauthorized access and especially against children.

---

## *Sodium hypochlorite or liquid bleach*

Liquid bleach is normally bought in bottles or sachets. Check that the contents are sodium hypochlorite and water only. The normal concentration of chlorine in liquid bleach is five per cent, but this may be lower if the bottle has been opened or stored for a long time (Fact Sheet 2.20 gives further details). Make up the solution as described in Box 1.

### **Box 1. Using sodium hypochlorite (liquid bleach) to make a chlorine solution**

- Fill three plastic buckets with clean water to about 5 cm from the top to allow for the bleach to be added. Most commercially available buckets hold 12.5 litres, but the quantity of water should be checked.
- Add enough liquid bleach to each bucket to make up a 0.2 per cent solution of chlorine.

Example : Capacity of bucket, 12.5 litres water = 12500 millilitres.

Need 0.2% or 0.2 grams of chlorine per 100 millilitres of water,

therefore  $\frac{12500 \text{ ml}}{100 \text{ ml}} \times 0.2 \text{ grams} = 25 \text{ grams}$  chlorine is needed per bucket.

Liquid bleach is assumed to contain 4% or 4 grams of chlorine per 100 millilitres,

therefore  $\frac{25 \text{ grams}}{4 \text{ grams}} \times 100 \text{ millilitres} = 6.25 \times 100 \text{ millilitres} = 625 \text{ millilitres}$  of

4 grams liquid bleach must be added to 12.5 litres of water to make a 0.2 per cent solution of chlorine.

So, 625 millilitres of liquid bleach must be added to each bucket of water.

- Mix the water and bleach well, before use.

---

## *Calcium hypochlorite or HTH*

Calcium hypochlorite or high test hypochlorite (HTH or HTHC) comes as white granules and can often be bought from a local ministry of health office or from commercial warehouses and pharmacies. Calcium hypochlorite is much stronger than liquid bleach and does not lose strength so quickly. Calcium hypochlorite comes in various forms which can have from 20 to 70 per cent chlorine. Fact Sheet 2.19 covers calcium hypochlorite in more detail.

The best type of calcium hypochlorite to use is high test hypochlorite (HTH or HTHC), as this normally contains 50 to 70 per cent chlorine. Always check with the supplier or on the side of the container to be sure of the percentage chlorine content. Make the chlorine solution as described in Box 2.

**Box 2. Using calcium hypochlorite to make a chlorine solution**

- Fill three plastic buckets with clean water to about 5 cm from the top to allow for the calcium hypochlorite to be added. Most commercially available buckets hold 12.5 litres, but the quantity of water should be checked.
- Add enough calcium hypochlorite to each bucket to make up a 0.2 per cent solution of chlorine.

Example : Capacity of bucket, 12.5 litres water = 12500 millilitres.

Need 0.2% or 0.2 grams of chlorine per 100 millilitres of water,

therefore  $\frac{12500 \text{ ml}}{100 \text{ ml}} \times 0.2 \text{ grams} = 25 \text{ grams}$  chlorine is needed per bucket.

If calcium hypochlorite contains 50% chlorine or 50 grams of chlorine per 100 grams of powder, then 25 grams (the amount of chlorine needed per bucket) is contained in

$\frac{25 \times 100}{50} \text{ grams} = 50 \text{ grams}$  of powder.

Therefore, 50 grams calcium hypochlorite must be added to 12.5 litres of water to make a 0.2 per cent solution of chlorine.

So, 50 grams of calcium hypochlorite should be added to each bucket of water.

- Mix the water and calcium hypochlorite well and leave to dissolve for an hour. Some white sediment will sink to the bottom of the bucket ; only the clear liquid should be used to disinfect the pipeline and the sediment should be thrown away.

## *Cleaning and disinfecting pipelines*

When laying pipes, each pipe should be washed well with clean water to remove any soil or other material. A nylon bottle brush on a long wire handle can be used to remove soil which is stuck in the pipe and to give the pipe a good general clean-out. A solution of 0.2 per cent chlorine can then be used to rinse out each pipe just before laying in the trench.

When using PVC pipes, make sure that the ends of the pipes to be joined are dry or the PVC cement will not work properly and may cause pipes to leak later.

If pipe laying is stopped for any time, for instance, during workers' breaks or overnight, the open ends of the pipeline should be plugged with a clean wooden or rubber bung to stop animals or dirty water getting in.

When the pipeline is completed, it should be filled with a 0.2 per cent solution of chlorine and left overnight to kill any germs left in it. If the pipeline discharges into a tank or a pressure-break box, then a control valve should be fitted at the inlet to the tank or pressure-break box and closed to stop the chlorine solution running out of the pipeline.

## Fact Sheet 2.27

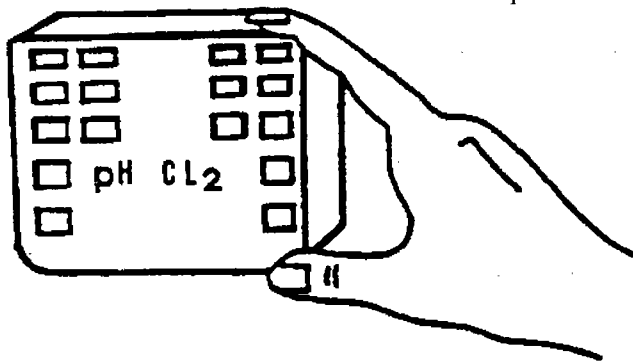
Once the pipeline is ready to be put back into service, the disinfecting solution should be drained and the pipeline flushed with clean water until a chlorine residual of 0.2 - 0.8 mg/litre is reached. The level of chlorine can be monitored using a pocket tester.

Many pipelines, particularly in urban areas which use surface water sources, carry continuously chlorinated water. This water is chlorinated in a treatment plant and should have free chlorine residual of at least 0.5 mg/l. In long pipelines it may be necessary to have re-chlorination tanks to ensure a safe water supply to the more distant points in the system.

---

### *Testing for bacteria*

All water supply pipelines should be tested for contamination with faecal bacteria every six months. If, some days after disinfection, a pipeline still has high levels of contamination, it may need to be continuously chlorinated. The level of chlorine in the pipeline should be checked every morning using a pocket tester as shown in Figure 1, to make sure that there is 0.2 - 0.8 mg/litre free chlorine residual in order to kill the germs. In large urban systems with routine chlorination, bacteriological tests should be done monthly and chlorine residual samples should be taken daily.



---

**Figure 1. Pocket chlorine tester**

## Cleaning and disinfection of tanker trucks

---

### *Why is it important to clean and disinfect a tanker truck ?*

When a tanker truck is used to transport drinking water, some contamination almost always gets into the tank. Other fluids may have been transported in the tank, for example, milk or irrigation water. Dust and dirt from repair workers may also get into the tank. It is important to kill any germs which are in the tank before it is used to store and transport drinking water.

Tanker trucks are often used in urban and peri-urban areas to deliver water to households. Tanker trucks can become very contaminated if they are not cleaned regularly and filled with properly chlorinated water for drinking. If one load of contaminated water is carried and the tanker not cleaned and disinfected, germs will live in the tanker and contaminate subsequent, possibly clean, loads.

Before filling with water, the inside of the tank should be spray-rinsed with a 0.2 per cent solution of chlorine using an electric or hand operated pump with a reservoir and hosepipe with a spray nozzle. After spraying the inside of the tanker, leave it closed overnight or for at least four hours. Before filling the tanker with clean drinking water, rinse the tanker out with clean drinking water. If the clean drinking water is chlorinated, then the tanker can be filled ready for deliveries.

---

### *Making up a chlorine solution*

There are various ways of disinfecting tanker trucks, but the most common is to use chlorine. The two forms of chlorine suitable for disinfecting tanker trucks are calcium hypochlorite and sodium hypochlorite. These are described in Fact Sheets 2.19 and 2.20.

Normally, a 0.2 per cent solution of chlorine should be made up using either sodium hypochlorite (liquid bleach) or calcium hypochlorite (HTH).

---

### *Safety for operators handling chlorine*

The operation and maintenance of equipment for dosing of chlorine from cylinders should only be undertaken by trained and authorized personnel.

Chlorine is a hazardous substance. In solution it is highly corrosive and splashes can cause burns and damage the eyes.

When handling concentrated chlorine solutions, appropriate precautions should be taken. Ideally, gloves and protective eye glasses should be worn. In the event of splashes and especially splashes to the eyes, it is important immediately to rinse thoroughly with water.

All containers in which chlorine is stored should be labelled, identifying the contents, and with a hazard warning in a form which is readily understood locally.

Storage sites for chlorine in any form should be secure against unauthorized access and especially against children.

---

## *Sodium hypochlorite or liquid bleach*

Liquid bleach is normally bought in bottles or sachets. Check that the contents are sodium hypochlorite and water only. The normal concentration of chlorine in liquid bleach is five per cent, but this may be lower if the bottle has been opened or stored for a long time (Fact Sheet 2.20 gives further details). Make up the solution as shown in Box 1.

### **Box 1. Using sodium hypochlorite (liquid bleach) to make a chlorine solution**

- Fill three plastic buckets with clean water to about 5 cm from the top to allow for the bleach to be added. Most commercially available buckets hold 12.5 litres, but the quantity of water should be checked.
- Add enough liquid bleach to each bucket to make up a 0.2 per cent solution of chlorine.

Example : Capacity of bucket, 12.5 litres water = 12500 millilitres.

Need 0.2% or 0.2 grams of chlorine per 100 millilitres of water,

therefore  $\frac{12500 \text{ ml}}{100 \text{ ml}} \times 0.2 \text{ grams} = 25 \text{ grams}$  chlorine is needed per bucket.

Liquid bleach is assumed to contain 4% or 4 grams of chlorine per 100 millilitres,

therefore  $25 \text{ grams} \times \frac{100 \text{ millilitres}}{4 \text{ grams}} = 6.25 \times 100 \text{ millilitres} = 625 \text{ millilitres}$  of 4 grams liquid bleach must be added to 12.5 litres of water to make a 0.2 per cent solution of chlorine.

So, 625 millilitres of liquid bleach must be added to each bucket of water.

- Mix the water and bleach well, before use.

---

## *Calcium hypochlorite or HTH*

Calcium hypochlorite or high test hypochlorite (HTH or HTHC) comes as white granules and can often be bought from a local ministry of health office or from commercial warehouses and pharmacies. Calcium hypochlorite is much

stronger than liquid bleach and does not lose strength so quickly. Calcium hypochlorite comes in various forms which can have from 20 to 70 per cent chlorine. Fact Sheet 2.19 covers calcium hypochlorite in more detail.

The best type of calcium hypochlorite to use is high test hypochlorite (HTH or HTHC), as this normally contains 50 to 70 per cent chlorine. Always check with the supplier or on the side of the container to be sure of the percentage chlorine content. Make the chlorine solution as described in Box 2.

**Box 2. Using calcium hypochlorite to make a chlorine solution**

- Fill three plastic buckets with clean water to about 5 cm from the top to allow for the calcium hypochlorite to be added. Most commercially available buckets hold 12.5 litres, but the quantity of water should be checked.

- Add enough calcium hypochlorite to each bucket to make up a 0.2 per cent solution of chlorine.

Example : Capacity of bucket, 12.5 litres water = 12500 millilitres.

Need 0.2% or 0.2 grams of chlorine per 100 millilitres of water,

therefore  $\frac{12500 \text{ ml}}{100 \text{ ml}} \times 0.2 \text{ grams} = 25 \text{ grams}$  chlorine is needed per bucket.

If calcium hypochlorite contains 50% chlorine or 50 grams of chlorine per 100 grams of powder, then 25 grams (the amount of chlorine needed per bucket) is contained in

$\frac{25 \times 100}{50} \text{ grams} = 50 \text{ grams}$  of powder.

Therefore, 50 grams calcium hypochlorite must be added to 12.5 litres of water to make a 0.2 per cent solution of chlorine.

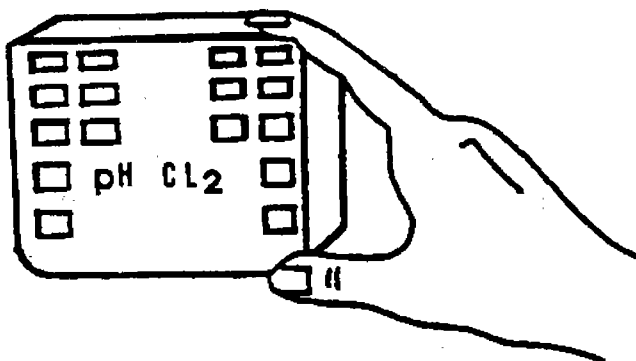
So, 50 grams of calcium hypochlorite should be added to each bucket of water.

- Mix the water and calcium hypochlorite well and leave to dissolve for an hour. Some white sediment will sink to the bottom of the bucket ; only the clear liquid should be used to disinfect the tanker truck and the sediment should be thrown away.

---

## *Water supply for tanker trucks*

If the water supply to be used is not chlorinated, then enough chlorine disinfectant should be added to the tanker to get a free chlorine residual of 1-1.5 mg/l. The level of free chlorine can be measured using a chlorine tester (see Figure 1).



---

**Figure 1. Pocket chlorine tester**

---

### *Testing for bacteria*

Tankers used for transporting drinking water should be tested for bacteriological contamination every month. If, some days after disinfection, a tanker still has high levels of contamination it may be necessary to chlorinate every load or change the source of water. Where chlorinated supplies are delivered, the level of chlorine in the water of each load should be checked using a pocket tester.



# Water quality monitoring

---

## *Concepts of on-site testing*

On-site testing of water involves using portable equipment to carry out testing in areas where there is no easily accessible laboratory. The equipment used for on-site testing generally relies on tablet reagents and simple hand-held instruments which do not need electricity or have special batteries which can be used for several days in remote areas and then recharged.

On-site testing has several advantages over laboratory testing :

- Samples do not need to be transported and so do not have time to deteriorate before testing ; more accurate results can therefore be obtained.
- Results are available locally immediately or the next day, so action can be taken rapidly.
- Local people can be more involved and can carry out some of the tests themselves, which helps to reinforce hygiene education messages.

---

## *Critical parameters of drinking water quality*

There are many different chemicals and microorganisms present in water which may harm our health, but even if it were possible to test for all these it would be impossible to remove them all without expensive treatment. Many of these contaminants are only rarely a problem or vary slowly and can be picked up by occasional screening of water samples. To carry out all analyses on every sample would be wasteful and expensive. It is recommended that a few basic tests are carried out regularly on all water supplies to see if there is a risk to health. Generally, four critical tests are recommended :

- *Faecal coliforms* - a family of bacteria which live in the gut of human and other animals and can get into water through excreta. If these bacteria are present in drinking water, those people who drink the water are at risk of catching diarrhoeal disease. Details of the test required to identify faecal coliforms in water are given in Fact Sheet 2.32.
- *Turbidity* - the cloudiness of water. Chlorine and other disinfectants may not work properly if the water is too turbid. Turbidity measurement is covered in Fact Sheet 2.33.

- *Chlorine residual* - the amount of chlorine in the water. Chlorine is a very effective disinfectant and kills many microorganisms. The amount of chlorine should be controlled to ensure that adequate chlorine is in the water to disinfect it properly, but that there is not so much as to be unacceptable. Testing for chlorine is covered in Fact Sheets 2.30 and 2.31.
- *pH* - a measure of the acidity of the water which can affect the ability of chlorine to kill microorganisms.

Tests for chlorine residual, turbidity and pH are always best done on-site, testing for faecal coliforms can be done on-site or at the laboratory base.

Portable kits which include all the critical tests, are available from various suppliers.

---

## *Sampling of water supplies*

When samples for water quality analysis are taken it is important that they are representative of the supply as a whole and also representative of conditions at the places most vulnerable to contamination, such as low-pressure points, ends of systems and storage tanks. The samples should also be representative of the supply over time. The source water of supplies frequently varies with the season, thus it is important that tests are taken to check that the supply provides safe water all year.

---

### **Frequency of sampling**

The frequency of water sampling and analysis depends on the size and type of water supply. Tables 1 and 2 below give the minimum frequencies of routine sampling and analysis under non-epidemic conditions. In general, all protected groundwater supplies should be tested twice yearly, once in the wet and once in the dry season. Surface water supplies with treatment plants should be tested

<b>Source and mode of supply</b>	<b>Bacteriological sampling and analysis</b>	<b>Physical/chemical sampling and analysis</b>
Open wells	once monthly	once monthly
Covered dug wells and tubewells with handpumps	twice yearly	twice yearly
Springs and piped supplies	twice yearly	twice yearly
Rainwater collection systems	once yearly	once yearly

<b>Population served</b>	<b>Minimum frequency of sampling</b>
Less than 5000	1 sample monthly
5000 - 100 000	1 sample per 5000 population monthly
Over 100 000	20 samples monthly plus 1 sample per 10 000 population monthly

During outbreaks of cholera, sampling and analysis should be more frequent than routine sampling and analysis. All water supplies should be chlorinated, and tests for chlorine residual and turbidity should be carried out daily. Bacteriological tests should be carried out as often as is feasible with available resources. Where chlorine residuals are low and turbidity high, a bacteriological test should be carried out as soon as possible. Water quality requirements in emergencies are covered in Fact Sheet 1.7.

### **Sample location**

When collecting water samples, it is important to ensure that they are representative of the quality of water supplied and the point of use.

Samples should be taken from locations which are representative of the water source, treatment plant, storage facilities, distribution network, points at which water is supplied to the consumer and where it is used. In selecting sample points, each locality should be considered individually. The following general criteria are usually applicable :

- Sampling points should be selected so that they are representative of the different sources from which water is obtained by the public or enters the system. Where more than one source supplies a system, sampling points should be located so as to take into account the number of inhabitants supplied by each source.
- Some samples should be taken from points representative of sources or places in the system that are more likely to be contaminated (such as unprotected sources, loops, reservoirs, low-pressure zones, and ends of the system).
- Sample points should be spread uniformly throughout a piped distribution system, in proportion to the number of links or branches, taking into account population distribution.

---

## *Chlorination in epidemic and disaster situations*

Water supplies present a means by which epidemic diseases such as cholera can be transmitted to large numbers of people very rapidly. In situations where diseases which can be transmitted by water (such as cholera, typhoid, hepatitis A and many diarrhoeal diseases) may spread, such as when an outbreak is recognized or a disaster occurs, it is vital that adequate drinking water supplies are assured.

Adequate supplies must be :

- of good quality ;
- continuously available ;
- accessible to all of the population ;
- available in adequate quantities to maintain human health ;
- affordable to all.

Many measures to improve drinking water quality are medium or long-term in nature. The response to outbreaks of infectious disease and disaster situations must be immediate. Attention should therefore focus on :

- protection of source water quality ;
- ensuring the optimal use of available treatment facilities ;
- emergency disinfection ;
- ensuring adequate household treatment and storage.

## Chlorine monitoring at point sources and in piped distribution systems

---

### *Chlorination in epidemic and disaster situations*

Water supplies present a means by which epidemic diseases (such as cholera, typhoid, hepatitis A and many diarrhoeal diseases) can be transmitted to large numbers of people very rapidly. In situations where such diseases may spread, for instance when an outbreak is recognized or a disaster occurs, it is vital that adequate drinking water supplies are assured.

Adequate supplies must be :

- of good quality ;
- continuously available ;
- accessible to all of the population ;
- available in adequate quantities to maintain human health ;
- affordable.

Many measures to improve drinking water quality are medium or long term in nature.

The response to outbreaks of infectious disease and disaster situations must be immediate.

Attention should therefore focus on :

- protection of source water quality ;
- ensuring the optimal use of available treatment facilities ;
- emergency disinfection ;
- ensuring adequate household treatment and storage.

---

## *Inventory of sources and initial testing*

Even where sources are adequately protected and water treatment undertaken, when there is an increased risk of water-borne disease it is good practice to instigate emergency disinfection. Emergency disinfection should cover *all* of the sources of drinking water used by the population. For this reason, it is important to make an inventory of water supply sources, both piped and non-piped, and organize regular monitoring of all of them.

Wherever possible, initial monitoring should include analysis for faecal indicator bacteria. Emergency disinfection should not await the results of water quality testing but be carried out immediately. Sources which are contaminated with faeces should be investigated, the source of contamination eliminated and the water re-tested. If contamination persists, then the population should be informed that the water is contaminated and that either alternative sources should be used or water should be treated in the home before use. Household water treatment is described in Fact Sheet 2.34.

Once the inventory is complete and initial testing has been undertaken, regular testing should be undertaken.

---

## *Testing for chlorine*

Free chlorine in water is unstable and the amount of chlorine in water may go down quickly, especially in warm climates. Sunlight and mixing of the water will cause free chlorine to disappear more rapidly. For this reason, chlorine testing should be carried out on-site and samples should not be taken back to the laboratory for analysis later as this may give false results.

---

## *Equipment and methods for monitoring chlorine residual*

The equipment needed and procedures involved in testing chlorine on-site are described in Fact Sheet 2.31.

---

## *Guidelines for chlorination of drinking water supplies*

To make sure that drinking water is free of pathogens (disease-causing microorganisms), a free chlorine residual should be maintained. The level of chlorine residual required varies with type of water supply and local conditions. There should, however, be a minimum of 0.5 mg/l residual chlorine after 30 minutes contact time in water.

Where there is a risk of cholera or an outbreak has occurred, the following chlorine residuals should be maintained :

<b>At all points in a piped supply</b>	<b>0.5 mg/l</b>
<b>At standposts and wells</b>	<b>1.0 mg/l</b>
<b>In tanker trucks, at filling</b>	<b>2.0 mg/l</b>

In areas where there is little risk of a cholera outbreak, there should be a chlorine residual of 0.2 to 0.5 mg/l at all points in the supply. This means that a chlorine residual of about 1 mg/l when water leaves the treatment plant is needed. Chlorine residual can be tasted in water at 0.8 mg/l, thus unless higher levels are vital for health reasons, it is recommended that such high levels are avoided at points of consumption.

---

### *Disinfection by repeated addition of doses of chlorine*

Disinfection by regular (daily or twice daily) addition of doses of chlorine is described for dug wells in Fact Sheet 2.21. In this case, the addition of chlorine may be conveniently combined with monitoring. The same person may be responsible for both testing and recording the concentration of free chlorine in the well, and for the addition of chlorine to the well.

Testing should be undertaken daily or more frequently if chlorine is added more than once per day. All results should be recorded.

The agency responsible for the surveillance of drinking water supplies should make periodic visits to inspect the installation, check that chlorine testing has been undertaken correctly, and take samples for testing for indicators of faecal contamination.

It is important that the person responsible for chlorine monitoring has clearly defined and readily accessible persons to contact when problems with either chlorination or chlorine monitoring are encountered.

---

### *Disinfection using a diffusion hypochlorinator*

Disinfection of wells using a diffusion hypochlorinator is described in Fact Sheet 2.21. Where the operation of the equipment (cleaning, filling with chlorine and installation in the well) is undertaken by a member of the community or by a person based in the community, then the monitoring scheme may be similar to that described above. In this instance, regular monitoring will ensure that fresh chlorine is added to the equipment as soon as concentrations drop below required levels (generally 1.0 mg/l). Monitoring should be carried out daily during epidemic and disaster situations. The frequency of testing may be reduced under other circumstances in the light of experience with the well in question.

---

### *Other types of water sources - surface water and springs*

Sources used for drinking water which are not enclosed (streams, lakes, and so on) should not be chlorinated without prior treatment. Such sources are usually contaminated. Alternative sources should be evaluated and, where appropriate, their use promoted. Where adequate alternative sources cannot be found, then the population should be informed of the contamination and of the need to treat water in the home.

Some other sources, such as springs, may be of good quality if adequately protected, but otherwise may be open to contamination. In these cases, disinfection at the source is generally impractical. Source protection is important and if there is any problem with water quality, the population should be encouraged to treat the water in the home.

---

### *Storage tanks in urban areas*

In urban areas, and often following disasters, storage tanks from which water is collected (similar to public standpipes) may receive water from tanker trucks or by similar means. In this instance source protection, adequate treatment and addition of chlorine should be ensured at the source from which the water is collected for transport to the tank. In addition, regular testing should be undertaken by a responsible person at the site of the tank. Testing should be undertaken on each batch of water on delivery and thereafter daily if the frequency of delivery is less than this.

It is important for the storage tank to be hygienically constructed and operated (see Fact Sheet 2.15).

---

### *Piped water supplies*

Where there is a risk of water-borne disease, piped water supply systems should be routinely chlorinated at the source or treatment plant and an adequate concentration of chlorine maintained throughout the distribution network. The purpose of monitoring is to ensure that chlorination at the source is continuous and that adequate concentrations are maintained in *all* parts of the distribution system.

Samples must be taken from locations which are representative of water from all sources after disinfection, including storage facilities, the distribution network, and points where water is delivered to consumers (domestic connections and public standposts).

Chlorine testing should be undertaken at least daily at sources and treatment plants, after disinfection of the water, and at storage tanks. A regular monitoring scheme should be established for water in the distribution network. The frequency of water sampling and analysis depends on the size and type of water supply. Tables 1 and 2 below give the minimum frequencies of routine sampling and analysis under non-epidemic conditions. In general, all protected groundwater supplies should be tested twice yearly, once in the wet and once in the dry season. Surface water supplies with treatment plants should be tested more often.



Source and mode of supply	Bacteriological sampling and analysis	Physical/chemical sampling and analysis
Open wells	once monthly	once monthly
Covered dug wells and tubewells with handpumps	twice yearly	twice yearly
Springs and piped supplies	twice yearly	twice yearly
Rainwater collection systems	once yearly	once yearly

Population served	Minimum frequency of sampling
Less than 5000	1 sample monthly
5000 - 100 000	1 sample per 5000 population monthly
Over 100 000	20 samples monthly plus 1 sample per 10 000 population monthly

During outbreaks of diarrhoeal disease, sampling and analysis should be done more frequently than routine sampling and analysis. All water supplies should be chlorinated, and tests for chlorine residual and turbidity should be carried out daily. Bacteriological tests should be carried out as often as is feasible with available resources. Where chlorine residuals are low and turbidity high, a bacteriological test should be carried out as soon as possible. Water quality requirements in emergencies are covered in Fact Sheet 1.7.

Sampling sites in the distribution network should be selected bearing in mind the density of population. Samples should be taken from sites which are most vulnerable to contamination and where there is a lack of persistence of chlorine residual. These include loops, low-pressure zones, dead-ends and sites known to be difficult.

It is essential to link chlorine monitoring to remedial actions, so that a course of action is agreed in advance and immediately implemented if results fall below agreed standards. Actions may include informing the public of the need to treat water in the home, increasing chlorine dosing and installing booster chlorinators where appropriate.

---

## *Household storage and disinfection*

In many areas it is common practice to store water in the home before use. Where this is the case, water may become contaminated and, although good quality water is being delivered by the distribution network, the water which the population consumes may be dangerous. For this reason, it is vital to consider hygiene education regarding household water treatment and storage. Household water treatment and storage is covered in detail in Fact Sheet 2.34.

# Chlorine testing

---

## *The importance of testing for chlorine in water*

Chlorine is added to drinking water to kill the microorganisms which cause typhoid, cholera, hepatitis A and other diarrhoeal diseases. Chlorine testing is important for the following reasons :

- If there is not enough chlorine in the water, the microorganisms will not be killed.
- If there is too much chlorine in the water, the users may not want to drink it because of the taste of chlorine and may be tempted to use other less safe water supplies.

---

## *Chlorine residual*

One of the advantages of chlorine as a disinfectant is that it is easy to measure both in a laboratory and in the field. Another advantage is that when chlorine is dosed correctly, it leaves a disinfectant residual which helps to prevent re-contamination in the distribution system or household storage tank. When chlorine cannot be detected in a distribution system, this may indicate that contamination has entered the system or that the dosing is incorrect.

Three types of chlorine residual can be measured :

- Free chlorine - which kills microorganisms most effectively.
- Combined chlorine - formed when free chlorine reacts with other chemicals in the water.
- Total chlorine - the sum of free and combined chlorine.

Free chlorine is the most important type of chlorine and a description of how to measure free chlorine is given below.

---

## *Sampling*

Free chlorine in water is unstable and the amount of chlorine in water may go down quickly, especially in warm climates. Sunlight and mixing of the water will allow free chlorine to disappear more rapidly. For this reason, chlorine testing should be carried out on-site and samples should not be taken back to the laboratory for analysis later as this may give false results.

# Chlorine testing

---

## *The importance of testing for chlorine in water*

Chlorine is added to drinking water to kill the microorganisms which cause typhoid, cholera, hepatitis A and other diarrhoeal diseases. Chlorine testing is important for the following reasons :

- If there is not enough chlorine in the water, the microorganisms will not be killed.
- If there is too much chlorine in the water, the users may not want to drink it because of the taste of chlorine and may be tempted to use other less safe water supplies.

---

## *Chlorine residual*

One of the advantages of chlorine as a disinfectant is that it is easy to measure both in a laboratory and in the field. Another advantage is that when chlorine is dosed correctly, it leaves a disinfectant residual which helps to prevent re-contamination in the distribution system or household storage tank. When chlorine cannot be detected in a distribution system, this may indicate that contamination has entered the system or that the dosing is incorrect.

Three types of chlorine residual can be measured :

- Free chlorine - which kills microorganisms most effectively.
- Combined chlorine - formed when free chlorine reacts with other chemicals in the water.
- Total chlorine - the sum of free and combined chlorine.

Free chlorine is the most important type of chlorine and a description of how to measure free chlorine is given below.

---

## *Sampling*

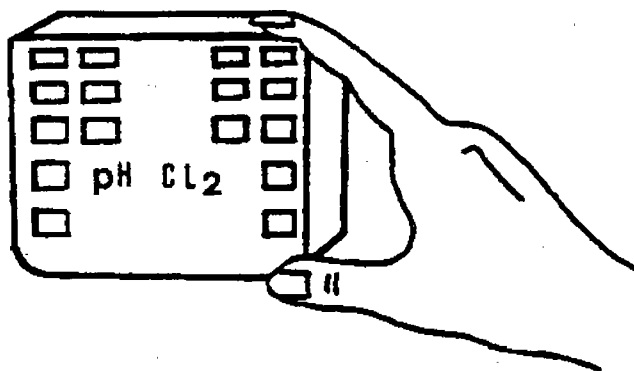
Free chlorine in water is unstable and the amount of chlorine in water may go down quickly, especially in warm climates. Sunlight and mixing of the water will allow free chlorine to disappear more rapidly. For this reason, chlorine testing should be carried out on-site and samples should not be taken back to the laboratory for analysis later as this may give false results.

---

## Testing methods

The method used for testing chlorine residual in water employs a chemical known as DPD (N,N-diethylparaphenylenediamine). Previous methods involved the use of OT (Orthotolidine) and starch-potassium iodide. OT is now known to cause cancer and so is not recommended, and starch potassium iodide only measures total chlorine residual and is therefore not recommended except where it is impossible to obtain DPD.

There are many types of equipment for measuring chlorine using the DPD reagent. The simplest and cheapest type, the chlorine comparator will be described here. Most comparators are designed for use with the manufacturers' reagents which normally come as small tablets packed in foil strips. It is important to keep a good stock of the reagents. This means that testing can be carried out quickly in the field without having to make up DPD solution. Figure 1 shows an example of a chlorine comparator.



---

**Figure 1. Chlorine comparator**

A DPD solution can also be used for the measurement of chlorine residual. This, however, needs to be done in a laboratory as a spectrometer, a filter photometer and titration equipment are required. The DPD solution also requires the preparation of a buffer solution and other reagents. This method can be very accurate, but it is beyond the scope of this Fact Sheet to give full details of the methodology and reagents required. If these are required, refer to a chemical methods manual. Generally, the level of accuracy given by the liquid DPD method is not required and the use of simple on-site tests are recommended in most circumstances.

---

## Measurement of pH

It is important to measure pH at the same time as chlorine residual, since chlorine works most effectively at pH values between 6.5 and 8.5. Outside this range, the water may need addition of chemicals to buffer the pH. This is usually done through addition of lime to acidic water (pH below 6.5) or of aluminium sulphate to alkaline water (pH above 8.5).

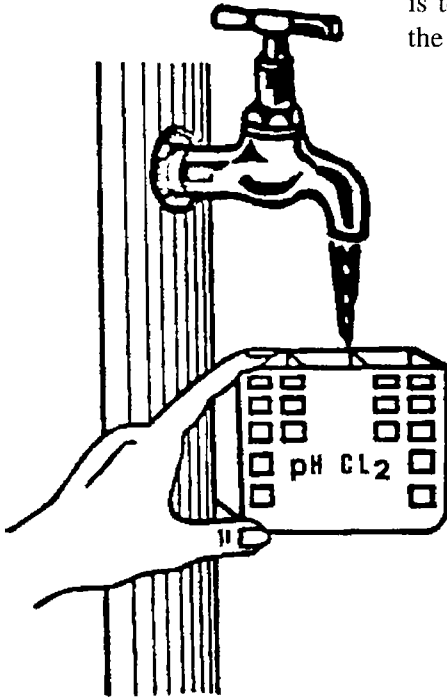
Some chlorine comparators allow pH to be tested at the same time as chlorine residual using a tablet reagent known as phenol red.

---

## Use of the chlorine comparator

The method of use of one type of chlorine comparator to measure chlorine in water is as follows :

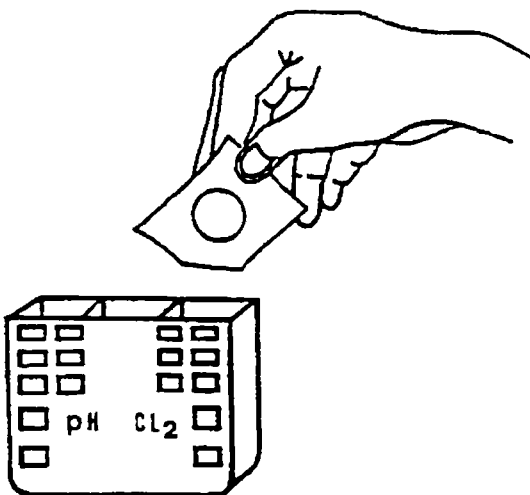
- Rinse the comparator cells three times with the water which is to be tested and finally fill all the comparator cells with the same water (see Figure 2).



---

**Figure 2. Filling the comparator cells with water**

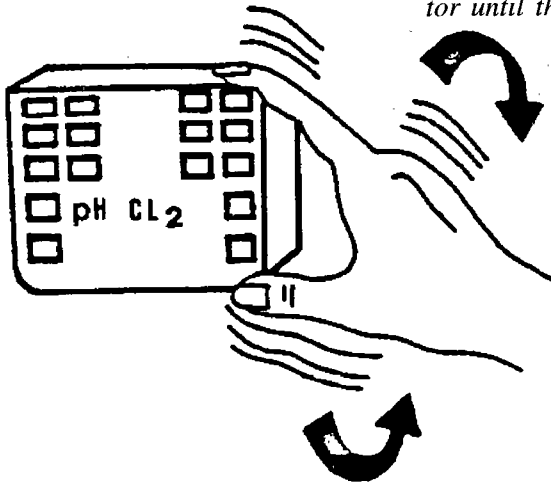
- Tear a foil strip containing DPD No. 1 tablets and allow one tablet to fall into the cell marked CL<sub>2</sub> in the comparator (see Figure 3).



---

**Figure 3. Adding a DPD tablet to a cell**

- If the comparator has a cell marked “phenol red” or “pH”, tear a foil strip containing phenol red tablets and allow one tablet to fall into that cell.
- Replace the lid on the comparator and shake the comparator until the tablets have dissolved (see Figure 4).



**Figure 4. Dissolving the tablets**

- Hold the comparator up to allow plenty of daylight to enter the cells and look at the water in the cells. If chlorine is present in the water, the dissolved DPD tablet should give a pink colour to the water. Match this colour to the nearest colour on the colour scale which is permanently fixed to the comparator and read the amount of chlorine in the water from the scale.
- If the comparator has a pH cell, compare the colour of the water in the cell with the permanent colour scale on the comparator and read the pH of the water from the scale.
- When the test is complete, remove the top of the comparator and pour the water onto soil, not into water supplies or other water sources. Wash the comparator out with clean water and store in a place where it cannot be damaged.

---

## *Guidelines for chlorination of drinking water supplies*

To make sure that drinking water is free of pathogens (disease-causing microorganisms) a free chlorine residual should be maintained. The level of chlorine residual required varies with type of water supply and local conditions. There should, however, always be a minimum of 0.5 mg/l residual chlorine after 30 minutes contact time in water.

Where there is a risk of cholera or an outbreak has occurred, the following chlorine residuals should be maintained :

<b>At all points in a piped supply</b>	<b>0.5 mg/l</b>
<b>At standposts and wells</b>	<b>1.0 mg/l</b>
<b>In tanker trucks, at filling</b>	<b>2.0 mg/l</b>

In areas where there is little risk of a cholera outbreak, there should be a chlorine residual of 0.2 to 0.5 mg/l at all points in the supply. This means that a chlorine residual of about 1 mg/l when water leaves the treatment plant is needed. Chlorine residual can be tasted in water at 0.8 mg/l, thus unless higher levels are vital for health reasons, it is recommended that such high levels are avoided at points of consumption.

---

## *Chlorine demand*

When chlorine is added to water, some chlorine is used up immediately by the water. This is the chlorine demand of the water. The chlorine demand of a particular water source normally does not change much over many years. When chlorine is added to water, there must be enough chlorine to satisfy the chlorine demand and also leave a small amount of chlorine residual (0.2 to 1.0 mg/litre) to kill the pathogens left in the water. It is important to be able to check the chlorine demand of water supplies to estimate the amount of chlorine needed for a well or rainwater storage tank.

The chlorine demand of a water supply can be estimated as follows :

- *Make up an approximately one per cent solution of chlorine or buy a bottle of bleach.*
- *Measure one litre of clean water and pour it into a container with a lid or cap.*
- *Add six drops of the one per cent chlorine solution to the litre of water, mix well and leave for 30 minutes.*
- *After 30 minutes, test the water in the container for free chlorine, as described above.*
- *The free residual chlorine in the water should be within the range of the comparator, usually between 1.5 to 2.0 mg/litre (or ppm). If the result falls outside this range, either add more drops of the one per cent chlorine solution or dilute with clean water, as necessary, until the free chlorine residual is in this range. If you add chlorine solution or dilute with clean water, leave the water in the container for 30 minutes before testing again. Note the result of the chlorine test as " original chlorine ".*



**Fact Sheet 2.31**

- *When the free chlorine residual of the water in the container is within the range 1.5 to 2.0 mg/litre, measure out 500 millilitres of the water and pour into a second container.*
- *Measure out 500 millilitres of the water to be tested for chlorine demand, for example from a well and pour this water into the second container with the chlorinated water. Mix well and leave for 30 minutes.*
- *After 30 minutes, test the water in the second container for free chlorine residual. Note the result of this chlorine test as "residual chlorine".*
- *Calculate the chlorine demand as follows :*

$$\text{Chlorine demand} = \frac{\text{Original chlorine}}{2} - \text{Residual chlorine}$$

*The chlorine demand is in mg/litre and should be added to the amount of chlorine needed to create a free chlorine residual of 0.2 to 1.0 mg/litre in a well or tank.*

# Bacteriological testing

---

## *The importance of testing for bacteria in water supplies*

The main risk to people using small community water supplies is from faecal-oral diseases such as cholera, typhoid, hepatitis A and other diarrhoeal diseases which are passed from excreta into the water supply. To test for the bacteria which cause these diseases would be very expensive and time-consuming, so the method generally used to check the hygienic quality of a water supply is to test for a certain type of bacteria found in large numbers in excreta.

These bacteria, known as faecal coliforms, are easy and cheap to test for both in a laboratory and with portable test kits. The test shows if there are bacteria from excreta in the water supply and therefore a risk of disease for people drinking the water.

---

## *Test methods for faecal coliforms*

It is beyond the scope of this Fact Sheet to give detailed descriptions of techniques for faecal coliform testing. If such information is required, you should refer to WHO *Guidelines for drinking water quality*, Volume I (Geneva 1995). This Fact Sheet aims to provide some general information about the most common methods used to analyse water for the presence of faecal coliforms.

When testing for faecal coliforms, it is important to be able to see how many faecal coliforms there are in a standard amount of water. The more faecal coliforms that are in the water, the greater the risk to health.

Two types of test are generally used to check for faecal coliforms in water :

- *Membrane filtration test* - this test uses a fine, sterile filter or membrane. A known quantity of the water to be tested is filtered through the membrane and any faecal coliforms in the water stick in the fine holes in the membrane. The membrane is placed on a culture medium which provides nutrients for the faecal coliforms and the membrane is then kept at 44°C in an incubator for between 14 and 18 hours. After incubation, any faecal coliforms will have grown to form "colonies" which can be seen with the naked eye and counted. The number of colonies is equal to the number of faecal coliforms in the water that was filtered.

This method does not work well when water is very turbid, as the turbidity will block the fine holes in the membrane.

- *Multiple tube test* - this test is sometimes called the “most probable number” method as it uses statistical tables to estimate the number of faecal coliforms in the water. The test is carried out by adding water to a series of tubes containing culture medium. The tubes are then incubated at 44°C for up to 48 hours.

The presence of faecal coliforms is shown by the formation of gas in the tubes and a colour change. The number of tubes which show the presence of faecal coliforms in the culture medium is then compared with statistical tables, and the number of faecal coliforms in the water is estimated.

The multiple tube method is time consuming and normally needs to be done in a laboratory. It can, however, be used to test samples of turbid water.

---

### *Choice of method*

The choice of a method for testing for faecal coliforms may depend on what equipment and consumables are available in the area. Membrane filters are often not available or very expensive in many countries, so only the multiple tube method can be used. Most portable testing kits for use on-site rely on the membrane filtration method which is simpler to use and gives more rapid results, but some new portable kits now use a multiple tube method.

---

### *Guidelines for faecal coliforms in drinking water*

Ideally in any water supply, there should be no faecal coliforms. In reality, there are often varying numbers of faecal coliforms in water supplies, so it is important to decide which water supplies need the most urgent action to improve them. This can be done by dividing water supplies into groups depending on the results of testing as follows :

Faecal coliforms	Action needed
0	None
1-10	Action
11-50	Urgent Action
50+	Very Urgent Action

In this way, work on improvement of water supplies can be prioritized to ensure that water supplies which represent the greatest risk to public health can be improved first.

# Turbidity measurement

## *The importance of measuring turbidity*

Turbidity is the amount of cloudiness in the water. This can vary from a river full of mud and silt where it would be impossible to see through the water (high turbidity), to a spring water which appears to be completely clear (low turbidity). Turbidity can be caused by :

- silt, sand and mud ;
- bacteria and other germs ;
- chemical precipitates.

It is very important to measure the turbidity of domestic water supplies, as these supplies often undergo some type of water treatment which can be affected by turbidity. For example, during the rainy season when mud and silt are washed into rivers and streams, high turbidity can quickly block filters and stop them from working effectively. High turbidity will also fill tanks and pipes with mud and silt, and can damage valves and taps. Where chlorination of water is practised, even quite low turbidity will prevent the chlorine killing the germs in the water efficiently.

Some treatment systems, such as sedimentors, coagulators and gravel prefilters are designed to remove turbidity. It is important for operators of both large and small treatment systems to know how well these systems are working. Measuring the turbidity of the water before and after each part of the system can tell the operator where maintenance or cleaning is needed.

---

## *Measuring turbidity*

Turbidity can be measured using either an electronic turbidity meter or a turbidity tube. Both methods have advantages and disadvantages, as shown below. Turbidity is usually measured in nephelometric turbidity units (NTU) or Jackson turbidity units (JTU), depending on the method used for measurement. The two units are roughly equal.

## *Turbidity meter*

There are many different types of electronic turbidity meter available. Their advantages and disadvantages are as follows :

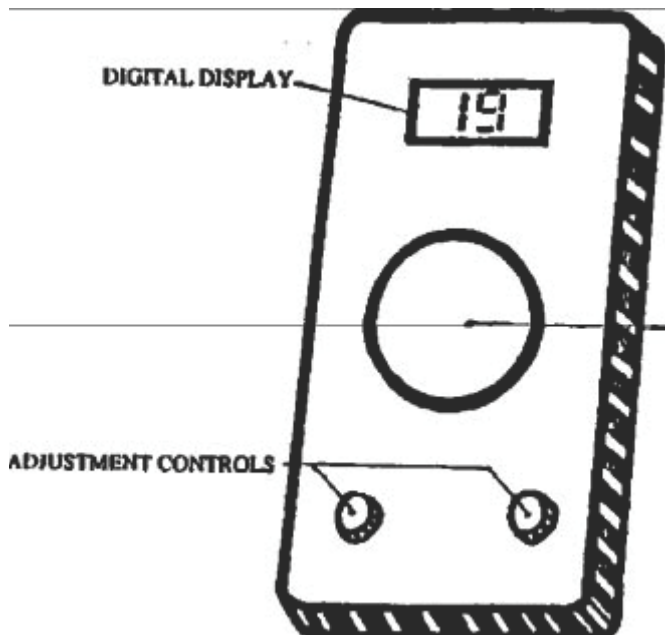
### **Advantages**

- very accurate, and especially useful for measuring very low turbidities (less than 5 TU)

### **Disadvantages**

- high cost
- need power supply (mains or battery)
- easily damaged

It is impossible to give general guidelines on their use here. You should refer to manufacturers' instructions for use and maintenance of these meters. Figure 1 shows an example of an electronic turbidity meter.



*Figure 1. Turbidity meter*

## *Turbidity tube*

The advantages and disadvantages of the turbidity tube are as follows :

### **Advantages**

- simple design
- low cost
- not easily damaged

### **Disadvantages**

- cannot measure very low turbidities (usual minimum is 5 TU)
- less precise

Since the turbidity tube is simple to use, instructions are given below. It is, however, recommended that you refer to the instructions provided with the tube that you are using. A turbidity tube is shown in Figure 2.



**Figure 2. A turbidity tube**

To measure the turbidity of a water sample using a turbidity tube :

- *Where the tube is in two parts, push the two parts together; making sure that they fit squarely.*
- *Take a sample of water from the water source.*
- *Hold the tube in one hand near the bottom and look into the open end **with** your head about 10 to 20 centimetres above the tube, so that you can clearly see the black circle,*

- *cross or other murk on the bottom of the tube.*
- *Slowly pour the water sample into the tube, waiting for air bubbles to rise if necessary, until the mark on the bottom of the tube just disappears.*
- *Stop pouring the water sample into the tube and look at the level of water in the tube. For turbidity tubes which have a turbidity scale marked on the side, read the number on the nearest line to the water level. This is the turbidity of the water. If the tube does not have a scale marked, measure the distance from the bottom of the tube to the water level with a tape measure and look up or calculate the turbidity of the water sample using the instructions provided with the tube.*
- *After use, wash the tube in clean water and store the two parts of the tube where they cannot be damaged.*

## *Turbidity guidelines for drinking water*

For drinking water supplies, the following guidelines should be taken into consideration :

- Drinking water should have a turbidity of 5 NTU/JTU or less. Turbidity of more than 5 NTU/JTU would be noticed by users and may cause rejection of the supply.
- Where water is chlorinated, turbidity should be less than 5 NTU/JTU and preferably less than 1 NTU/JTU for chlorination to be effective.

## Household water treatment and storage

Almost all water sources are open to contamination and many unprotected sources are very highly contaminated. Some water sources, especially surface water sources such as rivers or streams, may also have mud or silt in them making the water cloudy. To have clear water with no pathogens in it, a household must treat or purify the water. This does not require expensive chemicals or equipment ; household treatment systems can often be made with local materials to keep costs low.

Where local water supplies are known to be contaminated or have not yet been tested, household treatment should be recommended. Contaminated water can be purified in the home by using the following methods ;

- boiling,
- filtration,
- chlorination/disinfection.

---

### *Boiling*

Boiling drinking water is a simple way of killing pathogens. Boiling, however, has some disadvantages :

- It uses a lot of fuel. About 1 kilogram of wood is needed to boil 1 litre of water. The cost of fuel may prevent people boiling water in many areas.
- It can give an unpleasant taste to the water.
- Water can be contaminated again when it has cooled.
- Hot water can cause serious accidents in the home.

Water must be brought to a rolling boil for at least one minute. Where turbid water is used, it should be boiled for at least five minutes. Small bubbles in the water or steam above the water does not mean that the water is boiling. Water should be boiled, cooled and stored in the same container to avoid re-contamination. Ideally water should not be cooled by pouring from one container to another as this may allow pathogens to get into the water. Because this is a good way of improving the taste of boiled water which sometimes tastes “ flat ”, it is, however, commonly used. If it is practised, then care should be taken to ensure that both the containers are clean and disinfected.

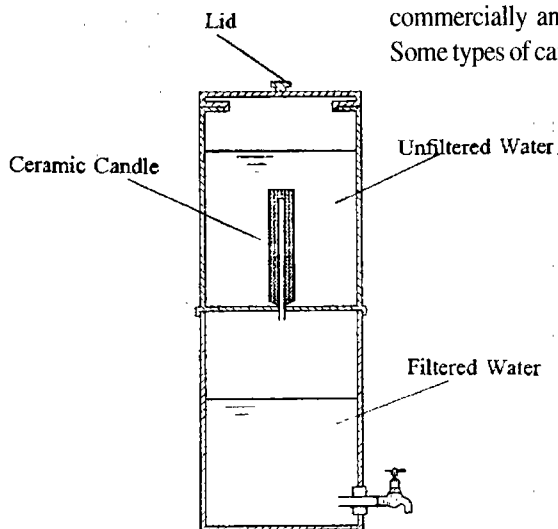


---

## Simple household filters (for turbid water)

There are several types of household filter :

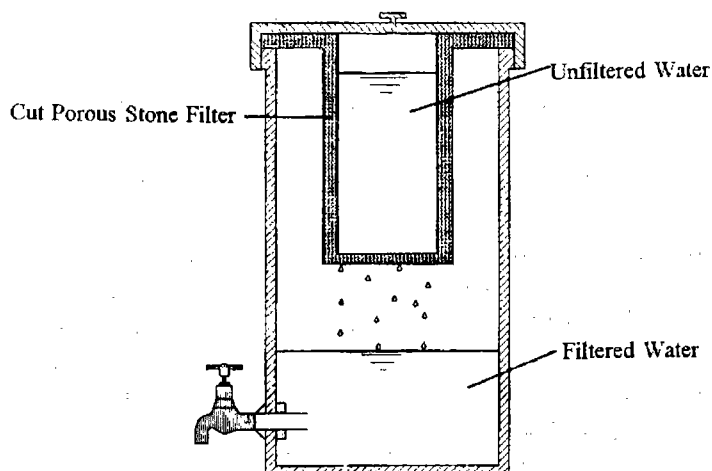
*Candle filter* - this type of filter allows contaminated water to filter slowly through a porous ceramic material (see Figure 1). Most pathogens are left in the outer layer of the filter material and must be washed away once every month by gently scrubbing the filter under clean, running water. Viruses such as hepatitis A are not removed by candle filters. Candle filters have to be made commercially and their quality carefully controlled. They are often expensive. Some types of candle filter have silver in them which helps to kill pathogens.



---

**Figure 1. Candle filter**

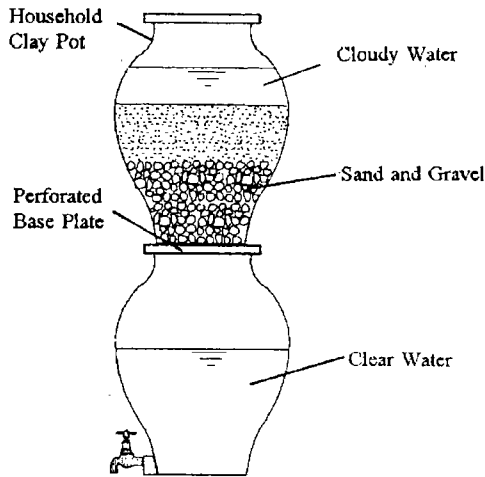
*Stone filter* - similar to the candle type filter, but carved from porous local stone (see Figure 2). This type of filter is difficult to clean and heavy to lift, but is usually quite cheap if the type of stone used can be found locally. The efficiency of these filters varies widely, however, and they often only remove turbidity but not germs.



---

**Figure 2. Stone filter**

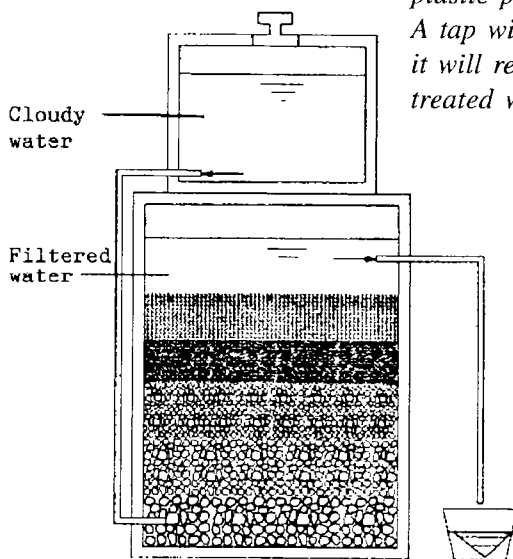
*Household sand filter* - this type of filter will remove solids and silt, and some pathogens, including guinea worm larvae, from water. It does not, however, remove all pathogens. Figure 3 shows household filters made from local materials.



**Figure 3. Examples of household filters**

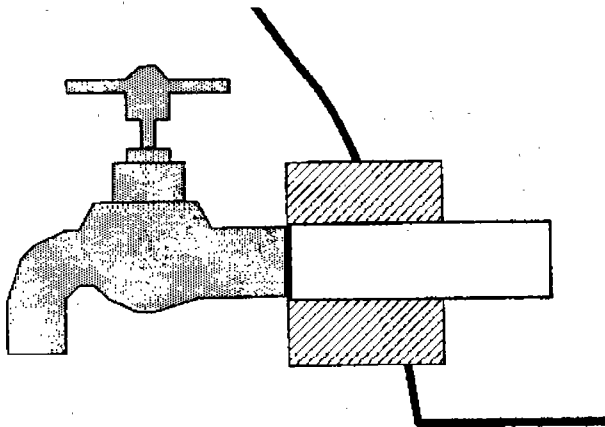
To make a household sand filter :

- *Find two containers made of fired clay or plastic and adapt them so that one fits on top of the other.*
- *Make some small holes in the base of the upper container either during the process of manufacturing the pot or by hand, drilling into the base of the pot to allow the water to pass through to the lower container.*
- *Make a hole near the bottom of the lower container to fit a tap and fix the tap with a short length of galvanized iron or plastic pipe and cement if necessary as shown in Figure 4. A tap will help prevent contamination of the stored water as it will reduce contact of hands and dirty objects with the treated water.*



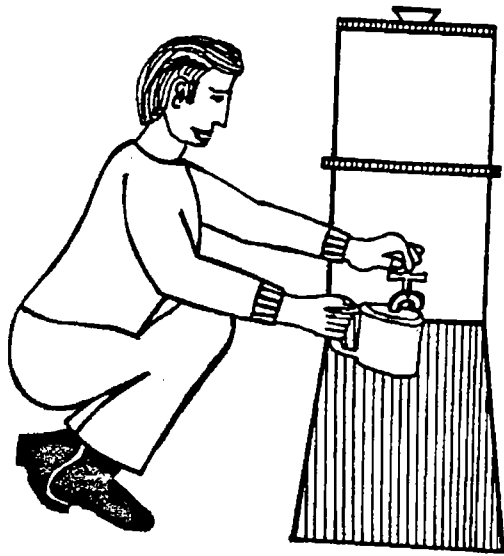
**Figure 4. Fixing a tap to a clay jar**

- Allow five days for the cement to become fully hardened before using the filter.
- Collect and wash enough small stones to cover the bottom of the upper container to a depth of about 5 to 7 centimetres. The stones should be big enough not to fall through the holes in the base of container.
- Collect some clean sand, preferably from a river bed, and wash it well. Add the sand to the upper container on top of the stones to a depth of 75 centimetres. Leave a 5 to 10 centimetre space at the top of the sand to allow water to stand on top.
- When the filter is finished, add water slowly to the top of the sand and allow it to filter through into the lower container.
- Try to add water several times a day to the filter so that there is always plenty of water in the lower container.
- When the lower container has filled above the level of the tap, water can be drawn from the filter (see Figure 5).



**Figure 5. Drawing water from the filter**

- When the filter is to be used for the first time, it is a good idea to throw away the first two gallons of water that have filtered through the sand to make sure that the sand has settled properly.
- If very cloudy river water is to be filtered, this will block the sand filter. The water must be left to stand in a closed container for 3 to 4 hours to settle out the earth or mud in the water (see Figure 6).



---

**Figure 6. Settling cloudy water**

- Eventually, the filter will block and the flow of water will become slower. When the filter no longer produces enough water, remove most of the sand from the filter, wash the sand thoroughly in clean water and then replace it in the filter.

It is very important to clean a household filter regularly. If it is allowed to get very dirty, the filter can make the water more contaminated than it was before.

Some more complex filters, such as slow sand filters, are very efficient at removing germs. Slow sand filters are generally difficult to operate in small households because a constant flow of water must be maintained. They are, however, useful for small community water supplies and a description of them is given in Fact Sheet 2.12.

---

## *Coagulation*

When the water from a river or stream is very turbid and carries a lot of suspended mud or silt, it can block a household filter. This tends to be more of a problem in the wet season. To make the water less turbid, local plants are often used to make the small particles of silt stick together and then fall to the bottom of the water container. This is a form of coagulation. The clear water can then be poured into the household filter without blocking it.

Many different plants are used for coagulation of turbid water in different parts of the world and it is difficult to provide general recommendations. It is important to investigate and build on local experience and practice.

---

## *Disinfection*

Household water which is contaminated but fairly clear can be disinfected to make it safe to drink. There are various ways of disinfecting household drinking water, such as using iodine, but the most common method is by chlorination. Normally, a one per cent solution of chlorine should be made up using either sodium hypochlorite (liquid bleach), calcium hypochlorite (powdered chlorine) or HTH (high test hypochlorite - a high strength powdered chlorine).

**CAUTION** Chlorine is a hazardous substance. In solution it is highly corrosive and splashes can cause burns and damage the eyes.

All containers in which chlorine is stored should have a label showing what type of chlorine is in the container and a warning that chlorine is dangerous. Places where chlorine of any type is kept should be locked. Chlorine solutions should be kept in a cool, dark, dry place in closed corrosion-resistant containers such as plastic, ceramic, dark glass or cement.

Household drinking water should not be disinfected with chlorine before filtering, as the disinfectant will be neutralized by the filter.

Disinfection does not work well in turbid or cloudy water, as the chlorine is absorbed by the suspended particles in the water. Chlorine disinfectant is available in several forms as follows :

*Sodium hypochlorite or liquid bleach* - liquid bleach is normally bought in bottles or sachets. Check that the contents are sodium hypochlorite and water only. The normal concentration of chlorine in household bleach is one per cent, but this may be lower if the bottle or sachet has been opened or stored for a long time.

*Calcium hypochlorite and HTH* - calcium hypochlorite and HTH are sold as white granules and can often be bought from a local ministry of health office or from commercial warehouses and pharmacies. Calcium hypochlorite is much stronger than liquid bleach and does not lose strength so quickly. Calcium hypochlorite comes in various forms which can have from 20 to 70 per cent chlorine. The best type to use is high test hypochlorite (HTH or HTHC), as this normally contains 50 to 70 per cent chlorine. Always check with the supplier or on the side of the container to be sure of the percentage chlorine content.

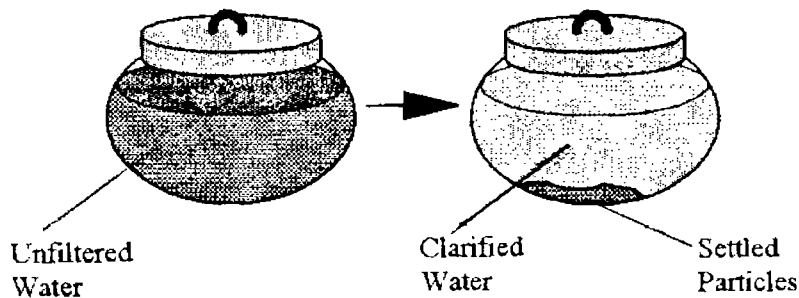
---

## *Disinfecting household drinking water*

When disinfecting household drinking water the one per cent chlorine is added to the water and left for 20 minutes to allow sufficient contact time for the chlorine to work. It is important to use the correct amount of chlorine, as too little will not kill all the germs present and too much may make the water unpalatable and cause consumers to reject the water. As a general rule, three drops of chlorine solution should be added to every litre of water. This can be done using a simple dropper tube or a syringe.

If sodium hypochlorite is used, it can be added directly from the bottle, as it comes with a chlorine concentration of one per cent. If calcium hypochlorite or HTH is used, they will need to be diluted to one per cent before being added to the water. The quantity of powder used will depend on the concentration of chlorine present. Check on the container or with the manufacturer's instructions.

A one per cent chlorine solution can be prepared from chlorine powder in various ways. These are covered in more detail in Fact Sheet 2.19. Strict attention should be paid to the manufacturer's instructions when preparing chlorine solution. Local materials can be adapted to measure chlorine powder or quantities of water to make up chlorine solution. Figure 7 shows an example of this.



**Figure 7. Local method for preparing chlorine solution**

When disinfecting water on a household basis, it is important to make sure that easily available local materials can be used to prepare the chlorine solution so that all households can chlorinate their water.

---

## *Chlorine demand and residual*

When chlorine is added to drinking water, some chlorine is used up immediately by the water. This is the chlorine demand of the water. The chlorine demand of a particular water source does not normally change much over many years.

When chlorine is added to water, there must be enough chlorine to satisfy the demand and also to leave a small amount of chlorine residual to kill the germs left in the water and help prevent re-contamination.

If the water has a high chlorine demand, 3 drops of chlorine solution in every litre of water may not be enough to leave a residual, and more chlorine will need to be added. A simple test to check that there is enough chlorine in the water, is :

- *Taste the water. You should be able to taste the chlorine slightly.*
- *If there is no chlorine taste, add one more drop of chlorine solution for every litre of water in the storage container and leave for 20 minutes.*

- *Taste the water again. If there is a slight chlorine taste, there is enough chlorine in the water.*
- *If there is still no chlorine taste, add one more drop of chlorine solution for every litre of water, wait 20 minutes and taste again. Repeat this operation as often as necessary.*

Some people do not like the taste of chlorine and will refuse to drink water with chlorine in it. This can mean that these people will then drink from unsafe water supplies. Adding lemon or other fruit juices to the water will help to hide the taste of the chlorine and make the water more acceptable.

---

## *Storage*

Good storage for the water is probably the most important way of keeping household water clean. It is a waste of time purifying water or collecting water from a clean source and then storing it where it can easily become contaminated. Storage containers therefore need to be well designed and should protect the water from contamination. The two most important factors influencing contamination of water storage containers are whether there is a lid or cover and the means of drawing the water from the container.

Storage containers without a lid or a cover will allow water to become contaminated rapidly because :

- Children or adults with dirty hands can put their fingers in the water and pass germs into it.
- Animals, such as cats or chickens, can drink directly from open containers and so pass on germs.

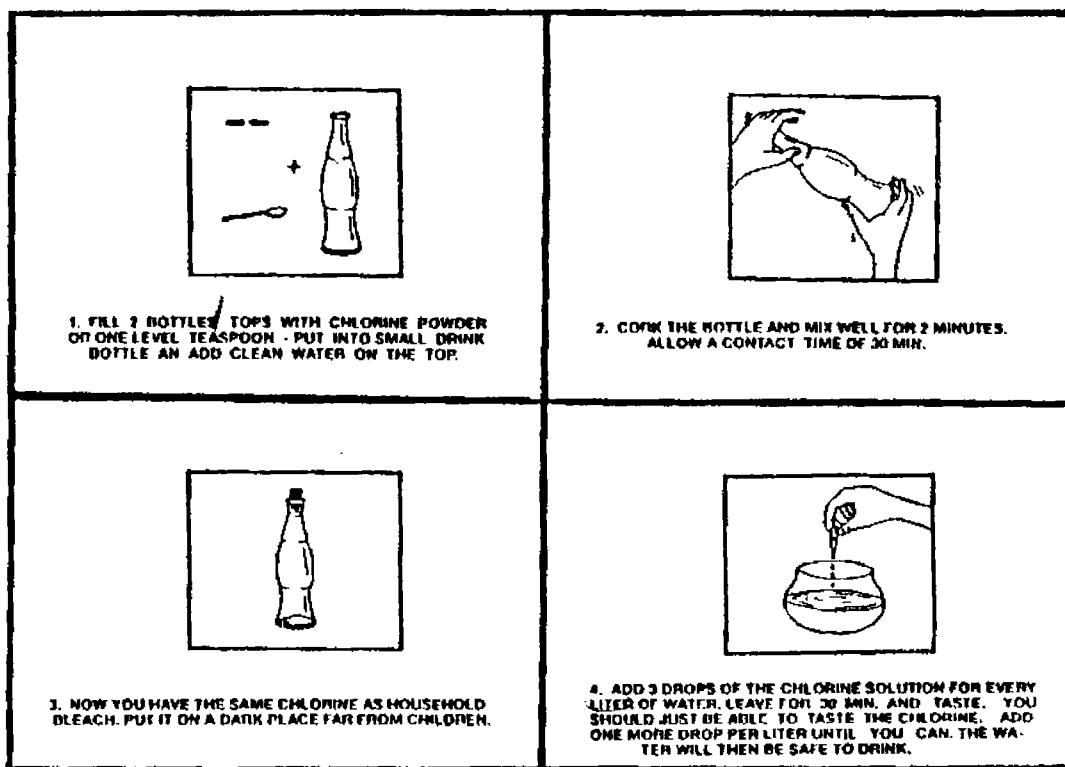
Storage containers should always have a lid, as shown in Figure 8

---

### **Figure 8. Water storage container**

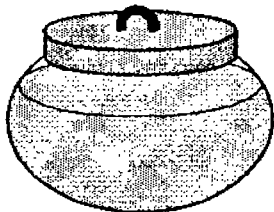
When water is taken out of the container there are many ways that pathogens can get into the water, for instance :

- When a dirty cup is dipped into the water container it will pass germs into the water.
- Water should be drawn from the container by a ladle or scoop, as shown in Figure 9. To prevent contamination, this ladle should not be used for any other purpose and should be kept in the water storage container with a small hole cut out in the lid to allow the handle of the ladle to stick out.
- If a ladle is left lying outside the water container flies can land on it and animals or humans with dirty hands can touch it. This will pass on germs to the ladle and so to the water the next time it is used.



**Figure 9. Using a ladle to draw water**

Another good way of preventing water in the storage container from getting contaminated is to pour the water from the container into a cup or to make water containers with narrow necks (see Figure 10).



**Figure 10. Water container with a narrow neck**

This way, fingers or cups never come into contact with the clean water and cannot contaminate it. In some areas, local ceramic water storage containers are made with taps so that water can be drawn from the tap.

In some countries, water is stored on the floor to keep it cool. This makes water more accessible to children and animals, and increases the risk of contamination. Water should be stored above the reach of children or animals. Earthenware jars or pots are good water storage containers, as they allow some water to evaporate thereby keeping the water cool. This does not present any problem of contamination, provided the water is covered and a sanitary means of water withdrawal is used.



# Excreta disposal options

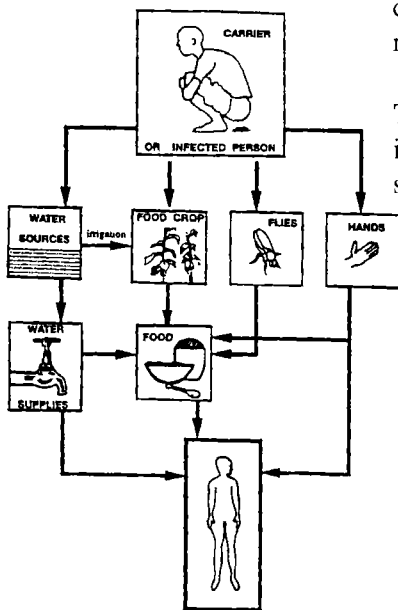
## Health aspects

Small amounts of excreta can carry enough germs to pass on a disease to someone else. So, even if water or food tastes and looks clean, it may have enough germs in it to pass on a disease to anyone who swallows it.

Not everyone who is infected becomes ill ; sometimes people can have a disease and show no

signs of illness. These people are known as asymptomatic carriers or healthy carriers. The germs grow in the gut of the carrier and pass out in their excreta ready to infect more people.

The excreta of all infected people are dangerous. It is impossible to know who is infected and so it is very important to dispose safely of all excreta. Figure 1 shows how disease is spread from excreta to infect new people.



**Figure 1. Spread of disease from excreta**

One of the key ways to stop the spread of disease is to promote and practise good hygiene. Even where there is excellent sanitation, disease will spread rapidly if hygiene is poor. Three key hygiene behaviours can do the most to prevent the spread of disease :

*Safer disposal of faeces* : all faeces, but particularly those of young children and babies, and of ill people, should be carefully and quickly disposed of.

*Handwashing* : if people wash their hands regularly with soap and water, particularly after defecating, after handling babies' faeces, before feeding and eating, and before preparing food, the germs on their hands are removed or killed.

*Maintaining drinking water free from faecal contamination* : the source of water must be kept clean, and in the home water must be stored in a clean covered container to prevent faecal contamination.

---

## *Selection of sanitation alternatives*

There are many different types of sanitation. The needs of the users and the resources available should be carefully considered to ensure that the most appropriate type of sanitation is selected.

To help select the most appropriate technology, the different types of sanitation technology are described briefly below. They are presented in more detail in the Fact Sheet referred to at the end of each section.

---

### *Simple pit latrine*

This is the cheapest and most basic form of improved sanitation available, and is generally only supplied on a household basis. It consists of a square, rectangular or circular pit dug into the ground, which is covered by a hygienic cover, slab or floor. This slab has a hole through which excreta fall into the pit. Depending on user preference, a seat or squat hole with footrests can be installed, and a lid should be supplied to cover the hole. The latrine is covered with a shelter and should be situated well away from water sources and some distance from the home.

As well as isolating the excreta, the simple pit latrine has the advantage of being easy and cheap to construct. Depending on the material used for their construction, the slab and shelter can be re-used. Simple pit latrines can, however, produce unpleasant smells and allow flies to breed easily. For more information on simple pit latrines see Fact Sheet 3.4.

---

### *Ventilated improved pit (VIP) and Reed's odourless earth closet (ROEC) latrines*

These are both improved types of pit latrine which aim to remove smells and flies from the latrine using a vent pipe. They use similar technology, the main difference being that the pit of the ROEC is wholly offset from the slab and connected to it by a chute, whereas the VIP pit is generally directly under the cover slab.

As with the simple pit latrine, a pit is dug into which the excreta fall. A cover slab with squat hole and a hole for a vent pipe is cast. A shelter is built, which must be kept semi-dark, and the vent pipe is raised to at least 0.5 metres above the top of the shelter. It is important that the latrine is well away from high buildings or trees.

These latrines share certain advantages : there are few problems with smell or flies ; the slab, vent pipe and shelter are re-usable ; and the excreta are isolated. Their disadvantages include the necessity of keeping the inside of the shelter semi-dark, which may discourage use of the latrine, and the maintenance required to ensure that the vent pipe remains in good working order. Another common problem with the VIP latrine is the difficulty of obtaining a durable fly screen for the vent pipe. In the case of ROEC latrines, the chute is easily fouled with excreta and so may allow

fly breeding. For more information on VIP and ROEC latrines see Fact Sheet 3.5.

---

## *Pour flush latrines*

Pour flush latrines use a pit for excreta disposal, but have a special pan which is cast in a cover slab and provides a water seal. This ensures that all the odours are kept in the pit, although sometimes a vent pipe is also fitted. These latrines require only 1-3 litres for each flush and are most appropriate where water is used for anal cleansing and where there is a reasonably good level of water service, for instance a public standpost or, more likely, a yard connection.

There are several types of pour flush latrines : those with a pit directly below the slab ; those with a single offset pit ; and those with two offset pits. Each type has advantages and some pour flush latrines can be installed in the house with a pit outside. Generally, the advantages of a pour flush latrine are that there are no problems with flies or smell, they are easily cleaned and there is no fear of falling into the pit. The disadvantages are that pour flush latrines are generally more expensive than other pit latrines to build and require water to function. For further information on pour flush latrines see Fact Sheet 3.6.

---

## *Composting latrines*

In the case of composting latrines, excreta and kitchen waste are disposed of and break down to produce compost which can be used as a fertilizer. There are two shallow pits or vaults, only one of which is used at a time. When one vault is full, it is covered with soil and closed for at least one year to allow the excreta to break down and become less harmful. While the first vault is closed, the second is used. When the second vault is nearly full, the first vault is opened and the dry, safe compost is dug out, leaving the first vault ready for use.

It is important that the vaults are kept dry to ensure that good compost is formed. Organic waste should be added daily to help the excreta break down and ash or powdered horse dung should be added after each use to absorb odours.

The advantages of composting latrines are that they do not need to be moved and new pits are not required once the latrine is full. The excreta can be used as a soil conditioner and the latrine also disposes of kitchen waste. Another important advantage is that a composting latrine can be built entirely above ground. The disadvantages are that they can be more expensive and difficult to build than other pit latrines and need a relatively high level of training to ensure their proper use. These latrines are most appropriate in rural areas where human excreta are used as fertilizer. For further information on composting latrines see Fact Sheet 3.7.

---

## *Aquaprivies*

The aquaprivy is a tank filled with water into which excreta fall. It uses a simple water seal to prevent odours getting out of the tank, and a soakaway to dispose of sullage and effluent. The drop pipe has to reach below the surface of the water in the tank to prevent the escape of odours. The tank must be watertight to prevent pollution of groundwater and should be emptied about every three years.

The advantages of the aquaprivy are that there are no problems with flies or smell, it cannot be blocked with bulky anal cleansing material, and it can be connected to a sewerage system at a later date. The disadvantages of the aquaprivies are that it is expensive to build, it needs water to work, the water seal can be hard to maintain where water cannot be added daily and in cold areas where it may freeze, and the tank must be emptied about every 3 years. For further information on aquaprivies see Fact Sheet 3.8.

---

## *Septic tanks*

Septic tanks are watertight chambers sited below ground level that receive both excreta and flush water from flush toilets and other

household sullage. The solids settle out and break down in the tank, whilst the effluent stays in the tank for a short while before overflowing into a sealed soakpit. Septic tanks must be emptied, usually mechanically, at regular intervals. Septic tanks allow safe disposal of wastewater, particularly in rural areas where wastewater is often discharged direct into rivers. Septic tanks can also be used in urban areas.

Septic tanks have the advantages of little maintenance, isolation of excreta, few problems with odour or flies and possible later connection to a sewerage system. Their disadvantages are the high cost of construction, recurrent mechanical emptying, the need for permeable soils so that soakpits can function properly, and the need for a piped water supply to the latrine. For further information on septic tanks see Fact Sheet 3.9.

---

## *Sewerage and sewage treatment*

Sewerage is the removal of excreta, flushing water from toilets and household sullage through a pipe network to a treatment works or disposal point. When this is operated correctly and the waste properly treated, sewerage can be an effective method of excreta removal. In many areas of the world, sewage is allowed to flow directly into rivers untreated ; this represents a major public health risk.

Sewerage is generally the most costly solution of the various excreta disposal options and alternatives mentioned in this Fact Sheet, although certain modified sewerage systems do offer substantial savings in capital expenditure. It is generally best employed in urban situations and where sufficient funds are available for its proper construction, operation and maintenance. In low-income areas, modified sewerage may be employed, which will allow a greater level of community management and maintenance.

The advantages of sewerage are that it can treat large amounts of water and provides great user convenience when connected. The main disadvantages are the generally high capital and operating costs, the large amount of flushing water required and the fact that the effluent still contains large numbers of germs. For more information on sewerage and sewage treatment, see Fact Sheet 3.11.

# Bacteriological testing

In 1990, at the end of the International Drinking Water Supply and Sanitation Decade, worldwide sanitation coverage was estimated by WHO to be 72 per cent in urban areas and 49 per cent in rural areas.

Large numbers of people defecate in the open air, particularly in rural and peri-urban areas of large cities. This increases the risk of the spread of infectious diarrhoeal disease such as cholera.

Proper sanitary facilities, such as latrines, should be built and used wherever possible instead of defecating in the open. The building of latrines is not, however, enough to stop open-air defecation completely. People must also wish to use the latrines.

Open-air defecation is a special problem where there are large numbers of travellers and at markets, festivals and other events attracting a large crowd. Children and some other sectors of the population may prefer to defecate in the open. It is very important that local hygiene education programmes discuss the dangers of defecating in the open field, and how they can be reduced. People should, however, always be encouraged to build latrines and use them.

The first step in improving defecation practices is to understand where people choose to defecate ; this may be, for example, in the forest, in the bush, on the beach, or on the riverbank.

In countries where people practise anal cleansing with water, it is very likely that they defecate in or near to water sources. It is almost certain that this will cause contamination when excreta are washed into the water by rain. The same is true when people defecate in wet paddy fields, as the water will eventually reach a stream or river. People should be encouraged to take the water they need for anal cleansing with them, in a container, and not defecate close to open water.

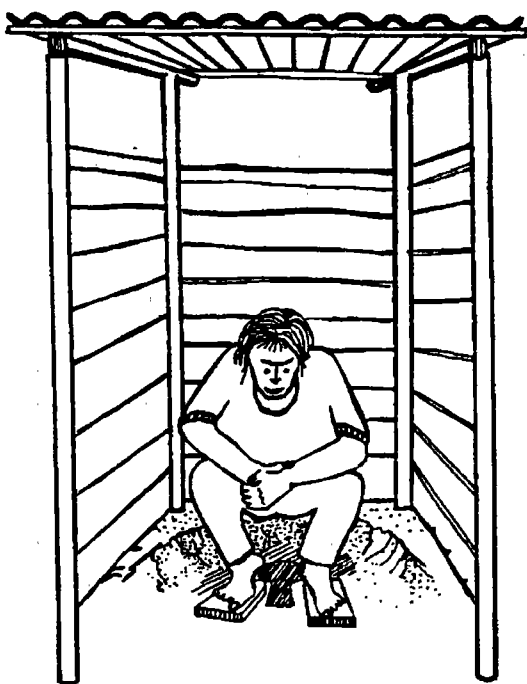
Using local hygiene campaigns, people should be shown how to dig a shallow hole to defecate into and then be encouraged to cover their excreta with earth. This will reduce the likelihood of animals and flies coming into contact with excreta. It is often difficult to convince people that they should take the extra time needed to dig a hole every time. If great care is taken to help people to understand the reasons, they can see that there are advantages, particularly if there is a threat of cholera or other diarrhoeal disease in the area. Hygiene promotion techniques are described in more detail in Series 4 of these Fact Sheets.

---

## *During an epidemic*

As an emergency measure whilst latrines are being built, each household should dig a pit of minimum dimensions 0.3 x 0.3 x 0.75 metres depth, at least 6 metres away from the house and the minimum safe distance from any water source. The latter is site specific and should be established for each water source on the basis on local hydrological and hydrogeological conditions.

A distance of 30 metres has been suggested for standard practice. It is recommended that this figure is taken as a guide to establishing a minimum safe distance in the absence of local studies which would lead to the adoption of smaller distances.



---

**Figure 1. Emergency latrine**

Family members should use this pit to defecate and urinate. They should cover their excreta over with a layer of earth each time they use the latrine. A shelter may be built around the pit from whatever materials are available to provide privacy and protection (see Figure 1).

The emergency latrine should not be promoted as a permanent solution to excreta disposal. Fact Sheet 3.1 provides information to help select the most appropriate excreta disposal option.

---

## *Teach children to use latrines*

Many children will not use a latrine. This may be because the latrine has a deep pit and is dark and frightening. Also, many small children think that snakes or monsters live in the pit, perhaps because adults or other children have told them this. It is very important to get children used to using the latrine from an early age so that it becomes a habit. It is usually much harder to get adults to start using latrines and to change their hygiene habits.

Many people believe that faeces from children and babies are harmless. This is not true. A child's faeces contains just as many germs as an adult's faeces and must be disposed of safely, by throwing the faeces into the latrine or burying them. Great care should be taken to wash the baby with soap and water after defecation and to wash hands after handling babies' excreta. Babies' nappies (diapers) must also be washed carefully with soap and water.

---

## *Emergency sanitation*

Where there are overcrowded conditions, for example in urban areas or refugee camps, then it is important to provide temporary latrines as quickly as possible. If communal latrines are to be constructed as a temporary solution, no more than 20 people should use one latrine and one or more individuals must take responsibility for daily cleaning and maintenance. A temporary trench latrine can be constructed for the short-term, whilst better latrines are built. A trench latrine can be built as described below.

---

## *Building an emergency trench latrine*

- Choose a convenient site the minimum safe distance from water sources.
- Dig a trench 0.3 metres wide by 0.75 metres deep. The length of the trench will depend on the number of users ; about 0.75 metres per user is enough. Two trenches about 5 metres long can serve about 100 people for a few days.
- Place boards along each side of the trench for people to stand on. Private cubicles can be made by building screens from local materials.
- Leave the earth from digging the pit in a pile near the trench, with a shovel. Each person covers over their faeces with a shovelful of earth to keep away flies and reduce odours.
- Store stocks of the traditional anal cleansing material used in the area close by, and top them up regularly.
- Close the trench when it is within 0.25 metres of ground level. Cover it over with earth and pack it down tightly. The area should not be disturbed for two years.

---

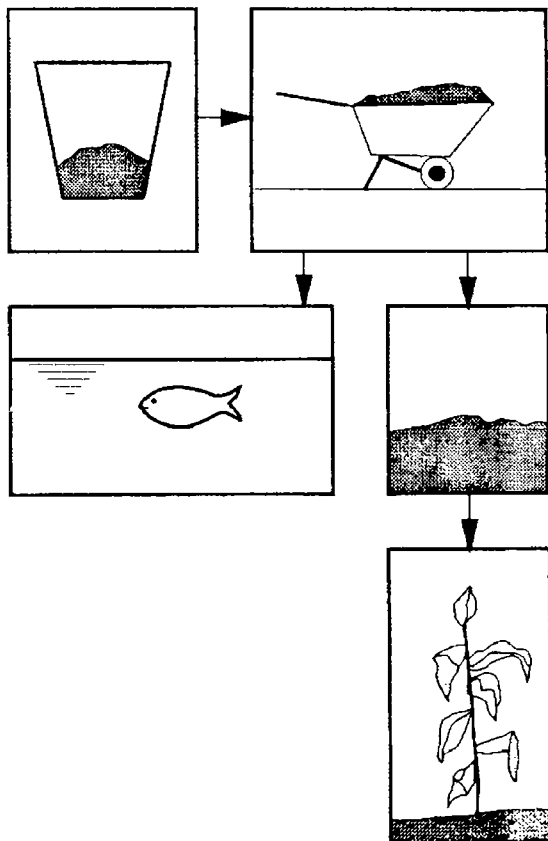
## *Building latrines*

In the long term, it is very important to ensure that there are safe means for excreta disposal and to encourage people to use them, to make sure that diarrhoeal diseases such as cholera do not spread. Fact Sheet 3.1 provides information on how to select the most appropriate excreta disposal option.

# Cartage

In some countries, excreta are stored in the home and must be removed regularly for disposal (this is referred to as cartage). After being taken away, the excreta are often used as fertilizer for crops or for fish farming (see Figure 1).

Cartage systems for the disposal of human excreta, especially if poorly planned and uncontrolled, present a very severe health risk to those who use them, those who transport the excreta, and through exposure to crops fertilized with raw excreta. Cartage is not recommended as an excreta disposal option. Where it is practised, every effort should be made to minimize the public health risk and to promote alternative, more hygienic, methods of excreta disposal.



**Figure 1. Cartage of excreta**



The cartage or carrying of excreta has the following disadvantages :

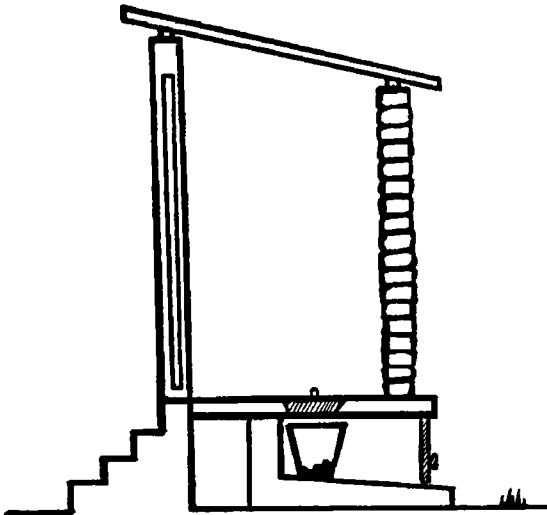
- With excreta in open buckets, flies are a problem.
- Odours emanate from the uncovered excreta.
- There are health risks to the people taking the excreta away from the house for disposal, either in buckets, in a cart, or using a tanker and pump which may involve handling pipes and other equipment contaminated with excreta.
- There are health risks from food crops fertilized with raw excreta.
- Cartage of excreta is expensive.

The only advantage of excreta disposal by cartage is the availability of excreta for preparation as a fertilizer.

---

### *Storage of excreta in the home*

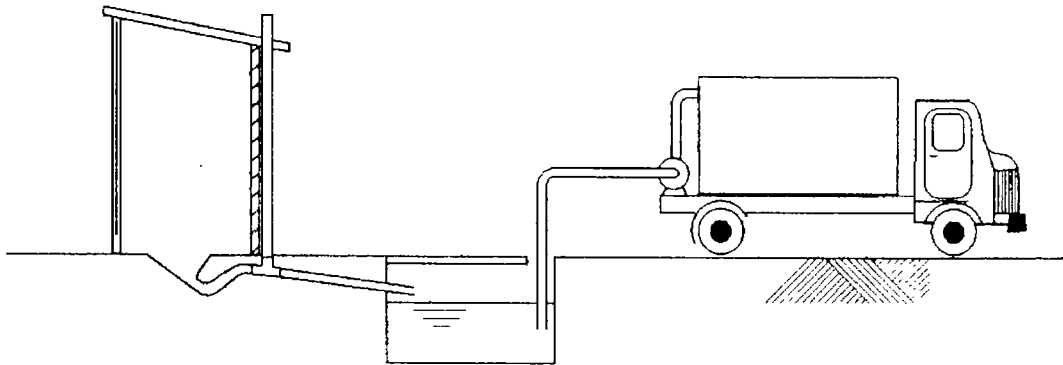
Latrines which allow the storage of excreta generally use a bucket or tank which can then be emptied. One type which is commonly used is the bucket latrine (see Figure 2).



---

**Figure 2. Bucket latrine**

In some countries, vault latrines store the excreta and water used for flushing in a tank below the house. The tank must be regularly pumped out by tanker and the excreta and water mixture, or sewage, must be disposed of (see Figure 3).




---

**Figure 3. Vault latrine being pumped out by tanker**

---

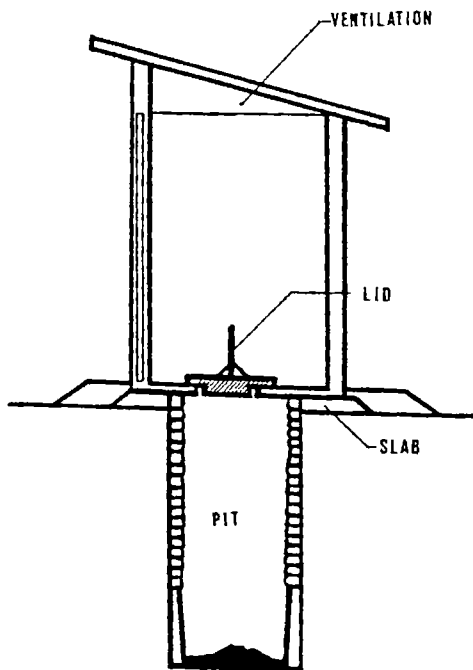
### *Reducing the public health risks of cartage*

Latrines using the cartage system are often a major risk to public health. In areas where there is a demand for excreta for use as fertilizer, cartage may be favoured locally. Because of the high public health risk associated with cartage, it cannot be recommended as an excreta disposal option. The public health risks can, however, be reduced in the following ways :

- Covers should be made for buckets containing excreta to stop flies getting to the excreta.
- Every time a bucket latrine is used, the fresh excreta should be covered with a small quantity of sawdust, ash, dry horse or cow dung, or dry soil to stop odours and to keep flies away.
- Protective clothing, for example gloves, should be used by people collecting buckets filled with excreta or operating tankers and pumps used to remove excreta from vaults.
- The excreta must be disposed of safely ; either buried in the ground in a special area or treated in a sewage treatment plant or lagoon system. Fact Sheet 3.11 describes sewage treatment plant and lagoons.

# Simple pit latrines

The simple pit latrine is the cheapest and most basic form of improved sanitation available. It consists of a square, rectangular or circular pit dug into the ground, covered by a hygienic cover slab or floor, with a hole through which excreta fall into the pit. Depending on user preference, a seat or squat hole with footrests can be installed, and a lid supplied to cover the hole. The latrine is covered with a shelter and fitted with a door, and is situated well away from water sources and some distance from the house. The simple pit latrine is most appropriate when water is not used for anal cleansing. An example of a simple pit latrine is shown in Figure 1.



**Figure 1. Simple pit latrine**

The simple pit latrine has the advantage of being easy and cheap to construct, the slab and shelter can be re-used, and the excreta are isolated. Simple pit latrines can, however, produce unpleasant odours and allow flies to breed easily.

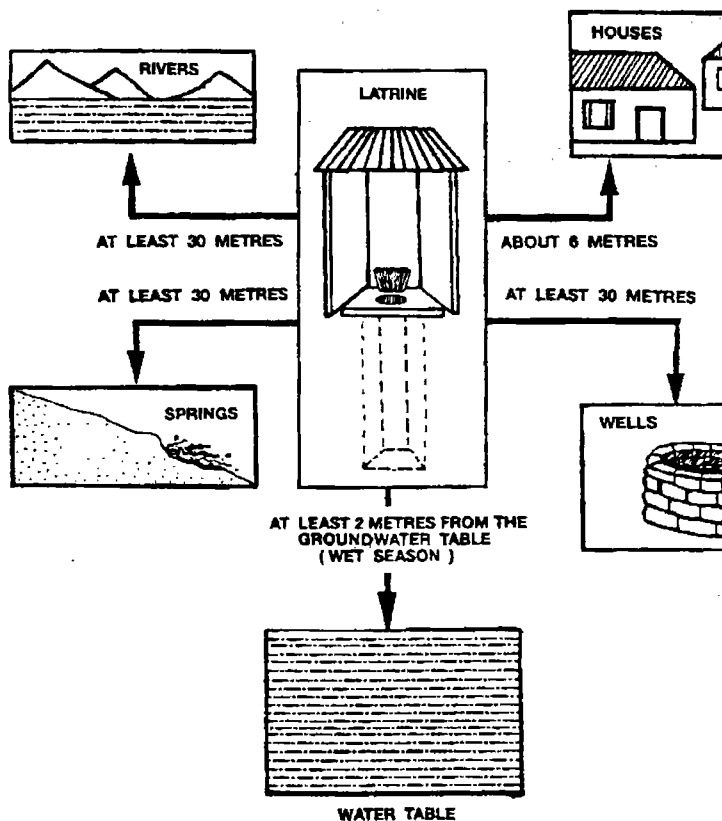
## *Where to build a pit latrine*

It is important to locate a latrine downhill from water sources wherever possible. Pit latrines should not be built uphill of a well, particularly in areas of fissured rock such as limestone, since faecal pollution may be carried directly through cracks and joints in the rock to the well. The latrine pit should not penetrate groundwater and should be at least two metres above the water table. The site should be well drained and above flood level.

Latrines should also be an established minimum safe distance from the nearest water source. This is site specific and should be determined for each water source on the basis of local hydrological and hydrogeological conditions. A distance of 30 metres has been suggested by some workers as standard practice. It is recommended that this figure is taken as a guide to establishing a minimum safe distance in the absence of local information.

The latrine should be a minimum distance of six metres from the house, so that it is easy to reach during bad weather but will not cause problems of odour in the house.

An example of where to locate a simple pit latrine is shown in Figure 2.



**Figure 2. Location of a simple pit latrine**

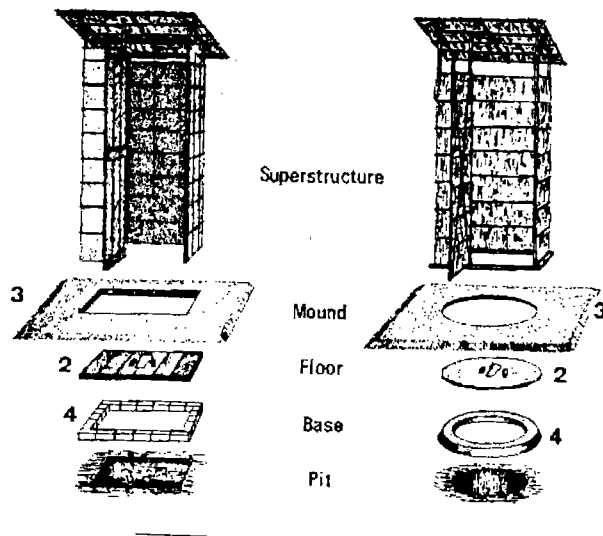
### *Problems with flies*

Flies should be prevented from breeding in the latrine where possible, as they can carry disease from the latrine to food. The common housefly lays its eggs in excreta and also crawls and feeds on the excreta, picking up germs on its body and legs. The germs are then deposited on human food when the fly comes into contact with it. In this way, diarrhoeal diseases may easily be spread from human excreta to food. Once on the food, some germs can grow. In a few hours, one germ can produce many thousands of germs.

Flies are attracted by light and odour, and avoid darkness and dark surfaces. All openings leading to the excreta, including the seat or squat-hole, must be kept clean and closed when not in actual use.

## Components of a simple pit latrine

The simple pit latrine has five main components, as shown in Figure 3.



Reproduced from Wagner & Lanoix (1958).

**Figure 3. Pit latrine components**

## Size of the pit

The pit should be as deep as possible, at least 1.5 metres, with vertical sides and 1 to 1.2 metres in diameter. Circular pits have stronger walls than square ones, although they are more difficult to construct. A volume of at least 0.06 cubic metres per person for every year of anticipated life of the latrine is needed. This should not include the top 0.5 metres which will be filled with earth when the pit is full and a new latrine is built.

A greater volume, for example 0.1 cubic metres per person per year, should be allowed where bulky anal cleansing materials such as corn cobs or stones are used. An example illustrating how to calculate the required size of the pit is given in the box below.

Example: A family of six, two adults and four children who build a latrine to last for five years:

Assuming that 0.06 cubic metres is needed per person per year, the volume required will be 5 years  $\times$  0.06 cubic metres  $\times$  6 people = 1.8 cubic metres.

If the pit is 1 metre wide  $\times$  1 metre long, then a depth of 1.8 metres will be needed to provide this volume.

Adding 0.5 metres to the depth to allow for covering with soil when the pit is full means that the pit will have to be 2.3 metres deep.

Provided that the soil is sufficiently permeable, urine and the liquid part of excreta will seep into the ground through the walls and floor of the pit.

The pit should not be dug down into groundwater, and should be at least two metres above the water table, particularly where groundwater is used for drinking, for instance from wells or springs. This is because of the danger of contamination. If the water table is very high, then the latrine can be built on a mound, as described below.

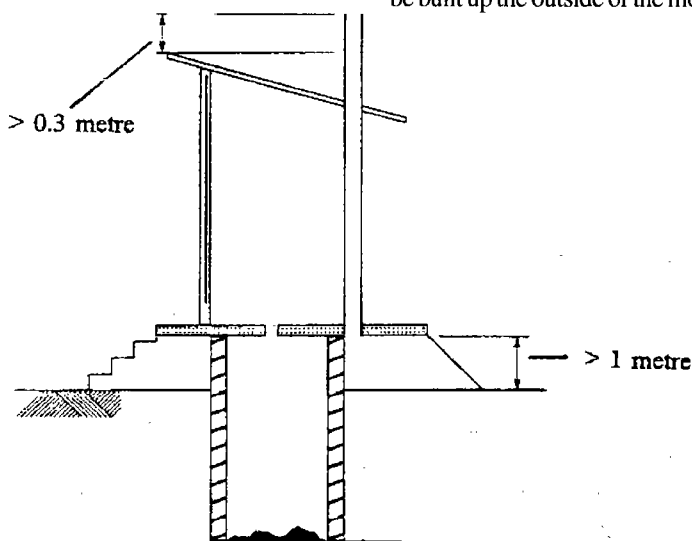
It may be necessary to provide support to prevent the pit walls from caving in. This is particularly important where latrines are dug in loose, sandy soil or clay soils prone to shrinkage. In stable soil, the top 0.5 metres of the pit should be lined, to support the squatting plate or floor.

---

## *Mound-built latrines*

The presence of solid rock or a high water table near the ground surface generally prevents the construction of pit latrines. In such circumstances, the latrine can be built on a mound, as shown in Figure 4.

The pit walls need to be built up at least 1.2 metres before the mound is constructed. The pit should be fully lined with stone, brick or concrete masonry and this lining continued above the ground to the top of the mound. Steps should be built up the outside of the mound using cement mortar.



---

**Figure 4. Mound-built latrine**

---

## *Lining the pit*

A wide variety of materials can be used to line the pit, as shown in Figure 5. Examples include concrete blocks, bricks, cement-stabilized soil blocks, masonry, stone rubble, perforated oil drums, and rot-resistant timber. Where blocks, bricks, masonry or stones are used, the lining joints should be fully mortared in the top 0.5 metres of the pit. Below this, the vertical joints should be left unmortared to allow the liquid part of the excreta to infiltrate into the soil.

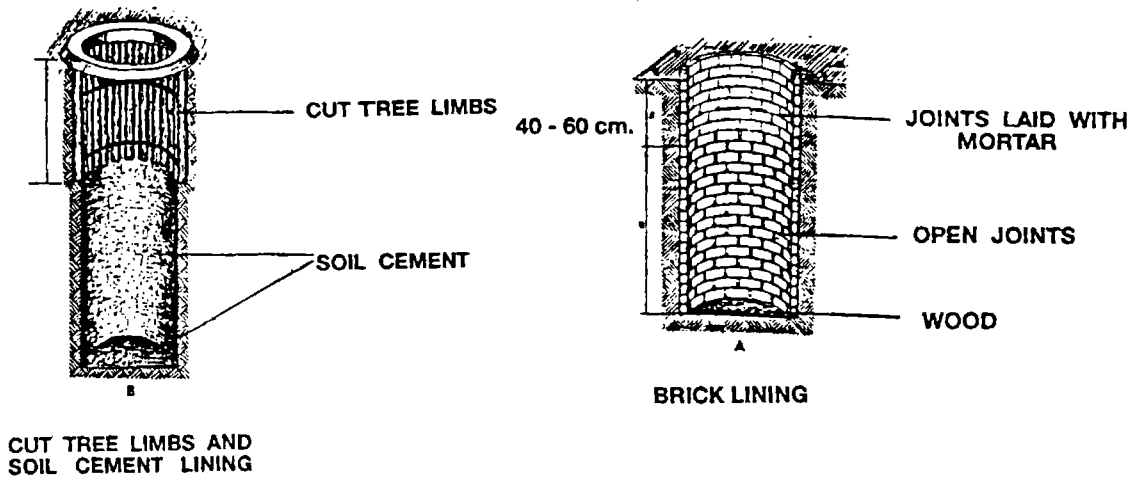


Figure 5. Types of pit linings

### The base or foundation

The base or foundation serves as a solid, impervious foundation upon which the floor (or squatting plate) can rest. It prevents the flooding of the pit by surface water and also helps to prevent the escape of hook worm larvae (which climb up the pit walls) and the entrance of burrowing rodents into the pit. The base should be high enough to raise the floor at least 100 to 150 millimetres above the level of the surrounding ground to protect the pit from flooding (see Figure 6). The base or collar may be circular or square.

The following materials may be used to construct the base or collar, depending upon local availability and cost :

- Plain or reinforced pre-cast concrete using a mix of cement : sand : gravel of 1 :2 :4 or 1 :3 :6.
- Brick - dried mud, burned mud, adobe, and so on.
- Rough-cut logs - hardwood and termite resistant.

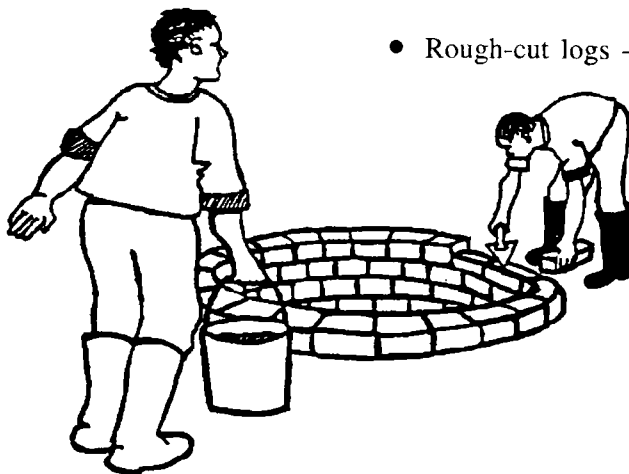


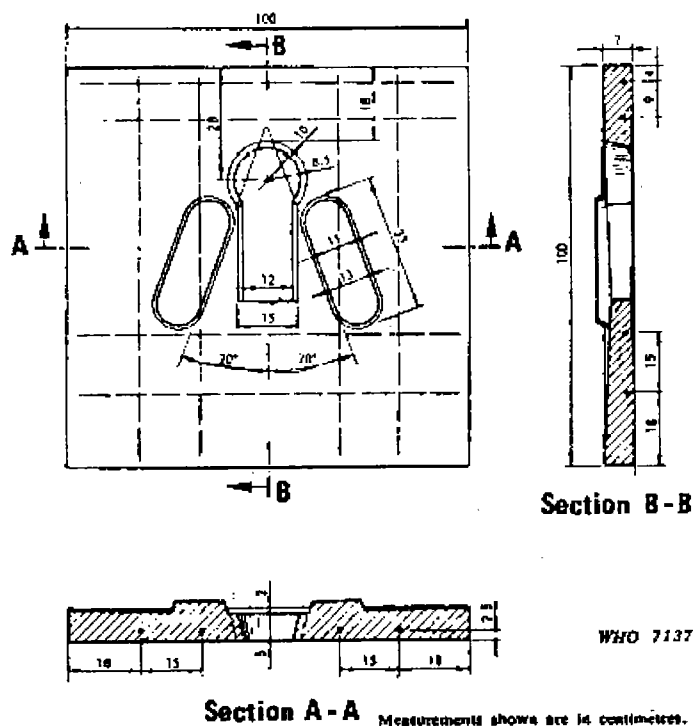
Figure 6. Latrine base or collar

## The floor or slab

The floor or slab supports the user and covers the pit. It should fit tightly and be flush with the outer edge of the base. The slab must be larger than the pit and rest firmly on the foundation or base to avoid the danger of collapse.

The floor or slab can be made from reinforced concrete, rot-resistant wood or bamboo covered with a layer of mud and cement mortar. The slab should have a smooth surface and slope towards the squat hole to provide easy drainage for urine and water used for cleaning the floor. A concrete slab is heavy and will need several people to lift it onto the base.

The floor or slab may be of the squatting type or provided with a raised seat. The opening should be no bigger than 250 millimetres, so that it is too small for a young child to fall through. A keyhole shape with foot rests, as shown in Figure 7, is ideal.



• Reproduced from Wagner & Lanoix (1958).

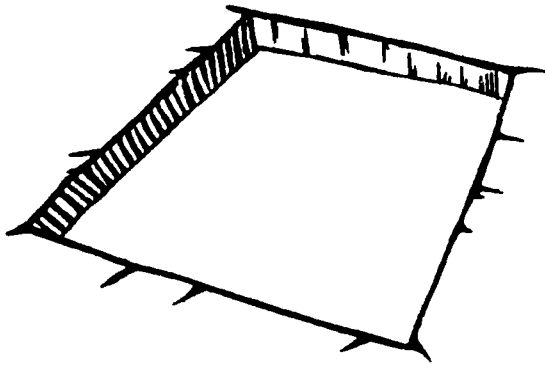
**Figure 7. Concrete floor or slab**

Instructions for making a simple floor slab are presented below.

To construct a simple reinforced concrete covering slab :

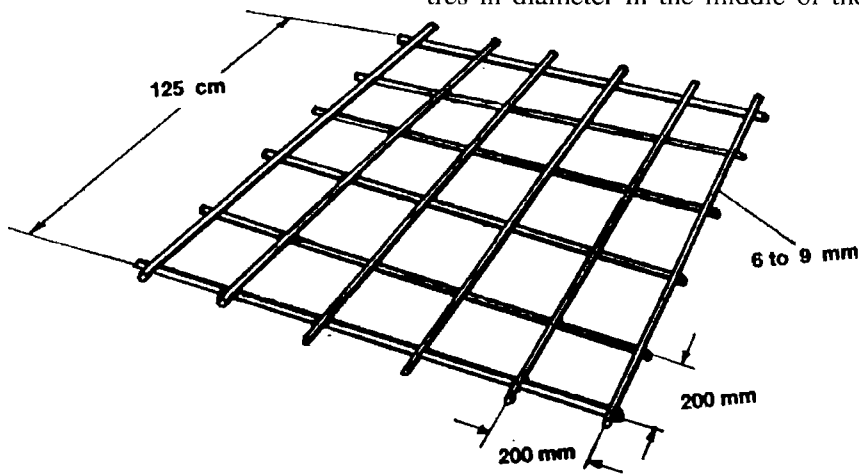
- Dig a square, shallow pit, about 200 millimetres wider and longer than the pit and 50 millimetres deep. Be sure that the bottom of the pit is level and smooth (see Figure 8).





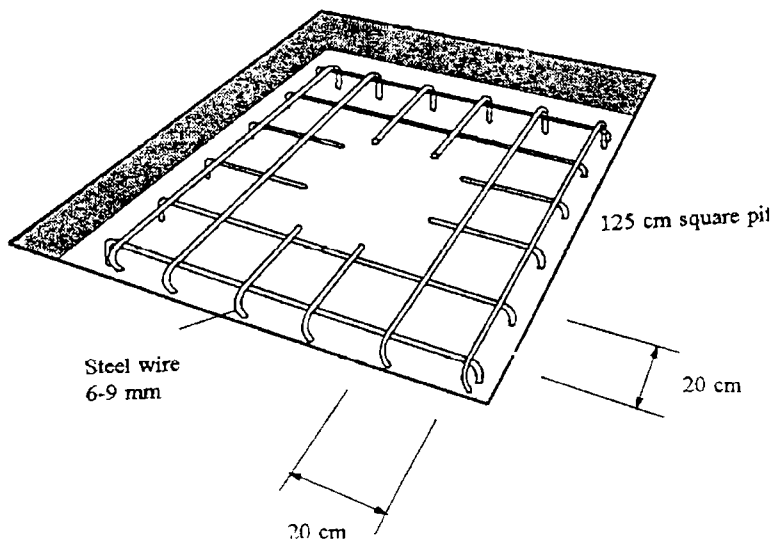
**Figure 8. Preparing a pit for cover slab casting**

- Make or cut a wire mesh or grid to lie inside the pit. The wires can be 6 to 9 millimetres thick and about 200 millimetres apart (see Figure 9). Cut a hole about 250 millimetres in diameter in the middle of the grid.



**Figure 9. Reinforcement grid**

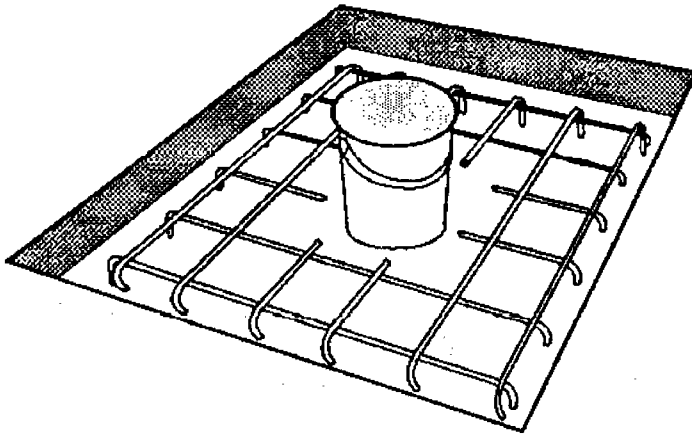
- Put the grid in the pit. Bend the ends of the wires, or put a small stone at each corner, so that the grid stands about 20-30 millimetres off the bottom of the pit (see Figure 10).



**Figure 10. Place grid in pit**

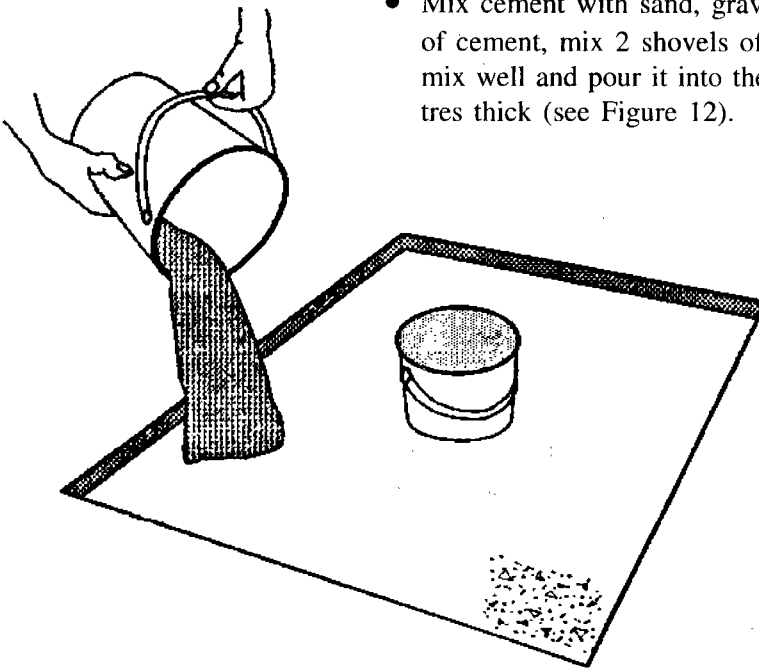
### Fact Sheet 3.4

- Put an old bucket with a bottom about 200 millimetres across or a template in the shape of a keyhole in the hole in the grid (see Figure 11).



**Figure 11. Making a squat hole**

- Mix cement with sand, gravel and water (with each shovel of cement, mix 2 shovels of sand and 4 shovels of gravel) mix well and pour it into the pit until it is about 50 millimetres thick (see Figure 12).



**Figure 12. Laying the slab**

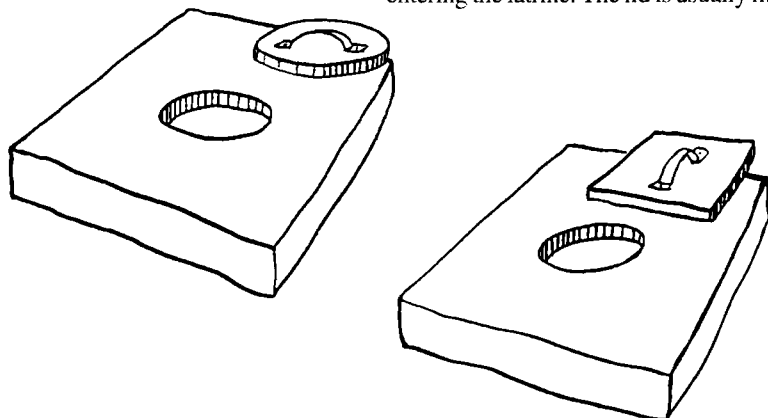
- Remove the bucket when the cement is beginning to harden (after about three hours). Then cover the cement with damp cloths, cement bags, sand, hay or a sheet of plastic and keep it damp. It is important that the cement is kept damp for five days to reach its full strength. Remove the slab after five days.

In some countries, a seat is more acceptable than a squatting plate. The seat can be made from concrete blocks or bricks, or wood.

---

## *The lid*

For simple pit latrines it is important to use a lid to cover the squat-hole or seat of the latrine. The lid keeps light out of the pit and helps to stop flies and odours entering the latrine. The lid is usually made from wood, as shown in Figure 13.




---

**Figure 13. Latrine pit lids**

---

## *The mound*

The function of the mound is to protect the pit and base from surface water run-off which otherwise might enter and destroy the pit. It should be built up to the level of the floor and be well tamped. It should extend at least 0.5 metres beyond the base on all sides. In exceptional cases, the mound may be built up considerably above the ground for protection against tides and flood waters.

The mound will normally be built with the earth excavated from the pit or surrounding area, and may be consolidated with a stone facing to prevent it from being washed away by heavy rains. In front of the entrance door, it is a good idea to supplement the mound with a masonry or brick-built step to add extra protection against wear.

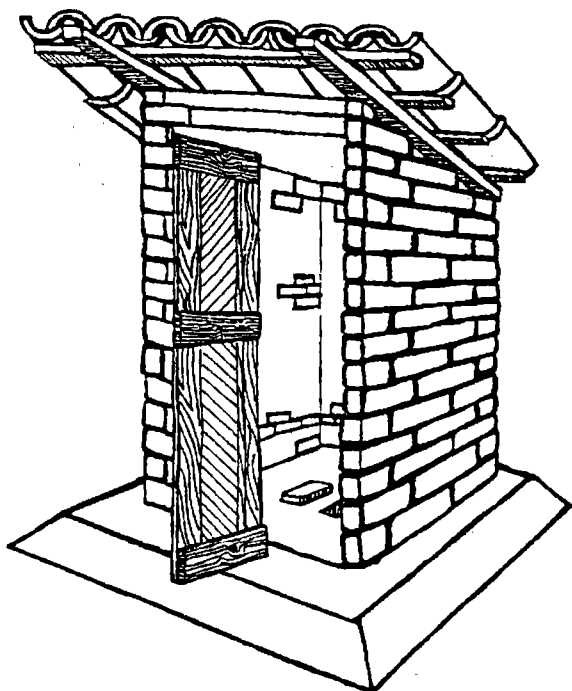
---

## *The shelter*

The shelter is for privacy and protects the user and the latrine from the weather. The shelter can be made from any suitable materials. Figure 14 shows one type of shelter.

The shelter is placed on the base of the latrine. The shelter should be high enough for comfort. The height will depend on the users of the latrine. Openings of 100 to 150 millimetres width should be provided at the top of the shelter walls for constant ventilation.

The roof should cover the shelter completely and have a large overhang to protect the mound and the walls from rain or roof drainage.



---

Figure 14. Example of shelter

---

### *Routine maintenance*

- Any grass or plants growing around the latrine should be kept well cut.
- Make sure that the door is kept closed.
- Keep the latrine floor clean by cleaning daily using water or ashes.
- Do not deposit tins, glass or plastic inside the pit.
- Household waste, such as vegetable or fruit peel, and organic matter, such as sawdust and leaves, may be placed in the latrine and can help to reduce odours, but will decrease the life of the pit.
- When the contents reach a level of 0.5 metres from the surface, then the contents of the pit should be covered over with soil and a new pit should be dug.
- During an epidemic, the floor of the latrine should be cleaned daily with a disinfectant such as bleach (sodium hypochlorite).
- To stop mosquitoes breeding in pits, pits should be kept as dry as possible. If too much water enters, ashes or dry horse or cow dung thrown in helps to absorb water and odours.
- No disinfectant should be added to the pit.

---

## *Upgrading of existing simple pit latrines*

The simple pit latrine is a common excreta disposal system used in many countries. Some are pleasant to use and contribute to the protection of public health. Others are less pleasant - particularly because of the odour - and may present a risk to public health, particularly if flies can enter and leave the pit. Upgrading simple pit latrines is straightforward and results in a more hygienic and pleasant latrine.

Common problems with simple pit latrines include the following :

- The pit is shallow and the shelter allows light into the pit, which attracts flies.
- The pit is unlined and built in unstable soils.
- The floor does not drain properly and is not smooth, so it does not facilitate cleaning.
- Lack of a lid or an ill-fitting lid which is not always immediately replaced after use.
- No ventilation pipe to carry odours away.

Important points to consider when deciding whether to upgrade a traditional pit latrine include the following :

- Relative cost compared to building a new latrine.
- Remaining useful life of the latrine pit.
- Structural soundness of the pit.
- User acceptability of upgraded design.

In general, a latrine should only be upgraded if it has at least three years of useful life left, otherwise a new latrine should be built.

---

## *Upgrading a simple pit latrine to a VIP latrine*

For fly control and to improve odour problems, a ventilation pipe can be installed. This converts the simple pit latrine to a VIP latrine (see Fact Sheet 3.5).

The minimum diameter of the ventilation pipe is 100 millimetres and the most convenient pipe to use is PVC. Other materials may be used, such as bamboo, fibre-cement or a square chimney made from bricks (internal diameter of 225 millimetres / 225 millimetres).

It is important that the vent pipe extends at least 0.5 metres above the peak of the roof. This will draw air up the vent pipe and carry odours away. The latrine

should be well away from tall buildings and trees to ensure that ventilation works efficiently. Ideally, the door of the latrine will face into the prevailing wind. The VIP latrine should not have a lid over the squat hole, which must be left open to allow air to flow into the pit.

The end of the vent pipe above the shelter roof needs to be covered with a fly screen. This can be made from aluminium or stainless steel or PVC-coated fibreglass. Other materials will corrode quickly. Flies are controlled by ensuring that the interior of the latrine is semi-dark, thus the main light entering the pit comes from the vent pipe. Flies are attracted up the vent pipe and are caught on the fly-screen and die.

Earthen floors can be improved by plastering them with a thin layer of cement to make them harder and smoother. In some areas, clay is mixed with other materials, for instance cow dung, to make a hard plaster finish for the floor. Alternatively, earthen floors may be replaced by a new reinforced concrete slab which incorporates a hole for the ventilation pipe and has foot rests either side of the drop hole. This would require the complete dismantling of the latrine and in these circumstances it may be better to build a new latrine.

# VIP and ROEC latrines

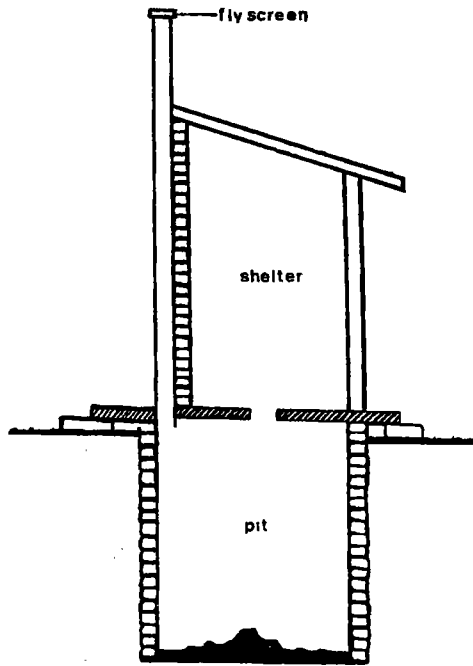
Ventilated improved pit (VIP) and Reed's odourless earth closet (ROEC) latrines are improved types of pit latrine which help to remove odours and prevent flies from breeding and escaping. Excreta are collected in a pit which has a vent pipe covered with a fly-proof screen at the top. The difference between the VIP and ROEC is that the pit of the ROEC is offset from the floor of the latrine and connected to it by a chute. The pit of a VIP latrine is directly under the floor slab (see Figure 1).

In these latrines, air circulates down the squat hole or chute, into the pit and up through the vent pipe. This reduces smells in the shelter. It is important that there is a free throughflow of air into the shelter and into the pit, therefore no cover should be placed over the squat hole or seat. In order to ensure an unhindered flow of air, the top of the vent pipe must be at least 0.5 metres above the top of the shelter and the latrine must be well away from high buildings or trees.

The shelter of the latrine is kept semi-dark so that the principal source of light into the pit comes from the vent pipe. Flies in the pit are attracted to the light from the vent pipe, but as the vent pipe has a fly-proof screen at the top they cannot escape and eventually die. Flies outside the pit attracted to the top of the vent pipe by the pit odour cannot enter because of the fly screen.

When the contents of the pit reach 0.5 metres from the top, the pit is filled with earth and a new pit dug. A fruit tree can be planted on the site or the compost can be dug out after two years (when it will be safer to handle) for use as a fertilizer.

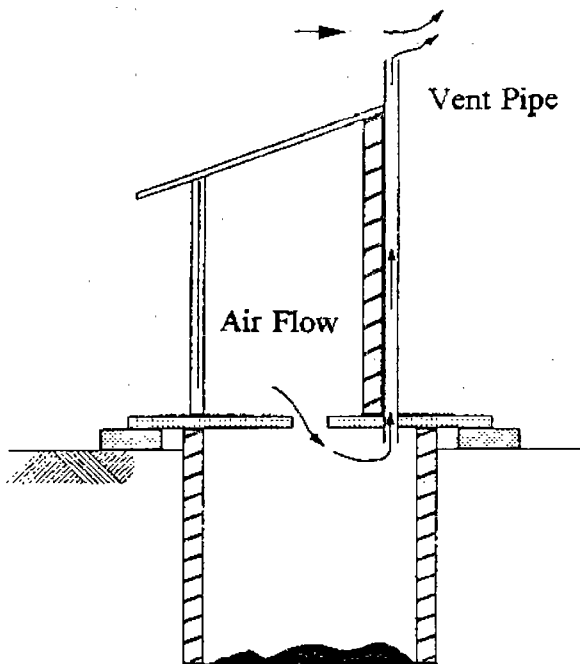
These latrines cost more to build and require more maintenance than a simple pit latrine. They are, however, still relatively low-cost and maintenance is straightforward. They are more pleasant to use than simple pit latrines because there is less smell and they are more hygienic. The ROEC has a greater capacity and needs replacing less often than the VIP, but the chute fouls easily with excreta and may allow fly breeding to occur. As with other latrines, if the VIP or ROEC are not used properly there is a risk of disease transmission.



**Figure 1. VIP latrine**

The VIP latrine is at its most efficient if it is built with the door or opening facing into the prevailing wind to allow air to flow easily into the latrine. Air passing over the top of the pipe causes air to rise up the pipe, which is replaced by new air drawn in through the squat hole. This is called the windshear effect and is shown in Figure 2. The exposure of the pipe to direct sunlight also causes air in the pipe to heat and expand, which draws cooler air up from the pit, thus facilitating the air flow from the latrine to the atmosphere.

The effect of the movement of air from the pit up the vent pipe to the atmosphere is to reduce the odour inside the shelter, as only a small proportion of the pit air will rise into the shelter.



**Figure 2. The windshear effect drawing air up the vent pipe**



---

## Where to build a VIP latrine

When planning a VIP latrine, the location must be carefully chosen :

- Downhill and an established minimum safe distance from the nearest drinking water source. The minimum safe distance will be site specific and should be determined for each water supply through an assessment of the hydrology and hydrogeology of the area. A distance of 30 metres has been suggested by some workers as standard practice. It is recommended that this figure is taken as a guide to establishing a minimum safe distance in the absence of local information.
- Near to, but downwind of the house.
- Not close to trees which will interfere with the airflow across the top of the vent pipe.
- On slightly raised ground so that rainwater can drain away easily.

---

## Size of the pit

The pit should be as deep as possible but not below the water table, at least 1.5 metres, with vertical sides and 1 to 1.2 metres in diameter. Circular pits have stronger walls than square ones, although they are more difficult to construct. A volume of at least 0.06 cubic metres, per person for every year of anticipated life of the latrine is needed. This should not include the top 0.5 metres which will be filled with earth when a new latrine is built.

A greater volume, for example 0.1 cubic metres per person per year, should be allowed where bulky anal cleansing materials such as corn cobs or stones are used.

---

Example: A family of six, two adults and four children who build a latrine to last for five years:

Assuming that 0.06 cubic metres is needed per person per year, the volume required will be 5 years  $\times$  0.06 cubic metres  $\times$  6 people  
= 1.8 cubic metres.

If the pit is 1 metre wide  $\times$  1 metre long, then a depth of 1.8 metres will be needed to provide this volume.

Adding 0.5 metres to the depth to allow for covering with soil when the pit is full means that the pit will have to be 2.3 metres deep

---

An example of the method for calculating pit size is shown in the box below.

Provided that the soil is sufficiently permeable, urine and the liquid part of excreta will seep into the ground through the walls and floor of the pit.

The pit should not be dug down into the groundwater and should be at least two metres above the water table, particularly where groundwater sources are used for drinking water, for instance from wells or springs. This is because of the danger of contamination of groundwater by faecal material. If the water table is very high, then the latrine can be built on a mound, as described below.

It may be necessary to provide support to prevent the pit walls from caving in. This is particularly important where latrines are dug in loose sandy soils or clays prone to shrinkage. In stable soil, the top 0.5 metres of the pit should be lined to support the squatting plate or floor.

---

### *Mound-built latrines*

The presence of solid rock or a high water table near the ground surface generally prevents the construction of pit latrines. In such circumstances, the latrine can be built on a mound, as indicated in Fact Sheet 3.4.

---

### *Lining the pit*

A wide variety of materials can be used to line the pit, as indicated in Fact Sheet 3.4. Examples include concrete blocks, bricks, cement-stabilized soil blocks, masonry, stone rubble, perforated oil drums and rot-resistant timber. Where blocks, bricks, masonry or stones are used, the lining joints should be fully mortared in the top 0.5 metres of the pit. Below this, the vertical joints should be left un-mortared to allow the liquid part of the excreta to infiltrate into the soil.

---

### *The base or foundation*

The base or foundation serves as a solid, impervious foundation upon which the floor (or squatting plate) can rest and prevent the pit from being flooded by surface water. It also helps to prevent the escape of hookworm larvae (which can climb up the pit walls) and the entrance of burrowing rodents into the pit. The base should be high enough to raise the floor at least 100 to 150 millimetres above the level of the surrounding ground to protect the pit from flooding (see Figure 3).

The following materials may be used to construct the base or collar, depending upon local availability and cost. The base or collar may be circular or square :

- Plain or reinforced pre-cast concrete, using a mix of cement : sand : gravel of 1 :2 :4 or 1 :3 :6.
- Brick - dried mud, burned mud, adobe, etc.
- Rough-cut logs - hardwood and termite resistant.



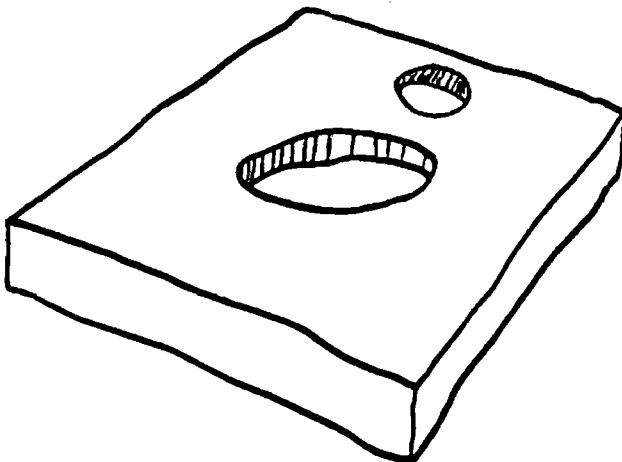
**Figure 3. Latrine base or collar**

### *The floor or slab*

The floor or slab supports the user and covers the pit. It should fit tightly and be flush with the outer edge of the base. The slab must be larger than the pit and rest firmly on the foundation or base to avoid the danger of collapse.

The floor or slab can be made from reinforced concrete, rot-resistant wood or bamboo covered with a layer of mud and cement mortar. The slab should have a smooth surface and ideally slope towards the squat hole to provide easy drainage for urine and water used for cleaning the floor. A concrete slab is heavy and will need several people to lift it onto the base.

The floor or slab may be of the squatting type or provided with a raised seat. The opening should be no bigger than 250 millimetres, so that it is too small for a young child to fall through. A keyhole shape with foot rests is ideal, as shown in Figure 4.



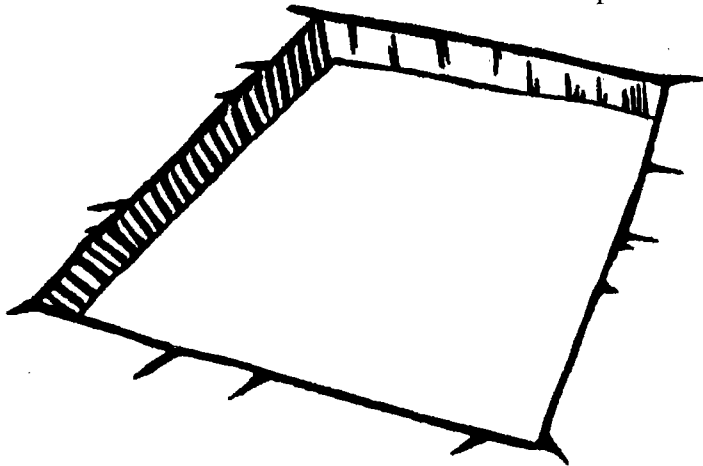
**Figure 4. Concrete floor or slab**

### Fact Sheet 3.5

Instructions for making a simple floor slab are presented below.

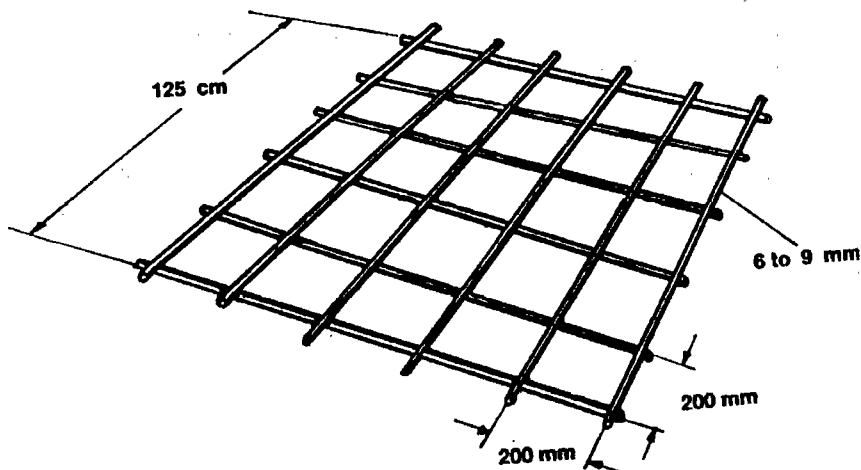
To construct a simple reinforced concrete covering slab :

- Dig a square, shallow pit, about 200 millimetres wider and longer than the pit and 50 millimetres deep. Be sure that the bottom of the pit is level and smooth (see Figure 5).



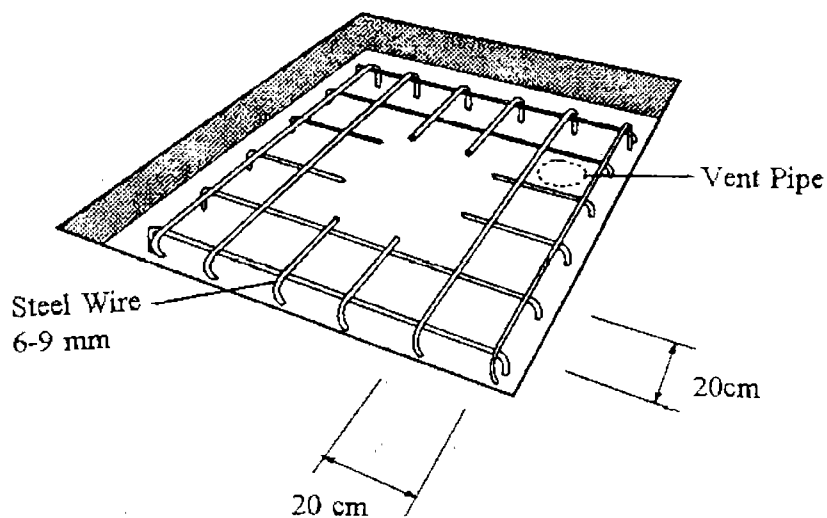
**Figure 5. Preparing a pit for cover slab casting.**

- Make or cut a wire mesh or grid to lie inside the pit. The wires can be 6 to 9 millimetres thick and about 200 millimetres apart (see Figure 6). Cut a hole about 250 millimetres in diameter in the middle of the grid.



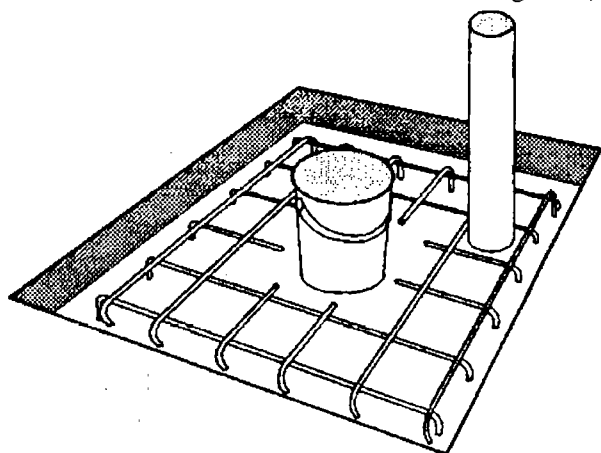
**Figure 6. Re-inforcement grid**

- Put the grid in the pit. Bend the ends of the wires, or put a small stone at each corner, so that the grid stands about 2-3 millimetres off the bottom of the pit (see Figure 7).



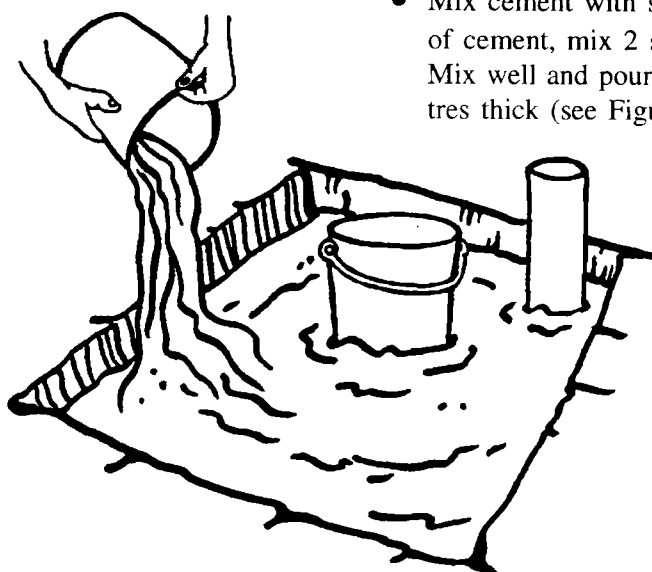
**Figure 7. Laying the grid in the pit**

- Put an old bucket with a bottom about 200 millimetres across or a template in the shape of a keyhole in the grid (see Figure 8).



**Figure 8. Making the squat hole**

- Mix cement with sand, gravel and water (with each shovel of cement, mix 2 shovels of sand and 4 shovels of gravel). Mix well and pour it into the pit until it is about 50 millimetres thick (see Figure 9).



**Figure 9. Laying the slab**

- Remove the bucket when the concrete is beginning to harden (after about three hours). Then cover the cement with damp cloths, concrete bags, sand, hay or a sheet of plastic and keep it damp. It is important that the concrete is kept damp for five days to reach its full strength. Remove the slab after five days.

---

### *The vent pipe*

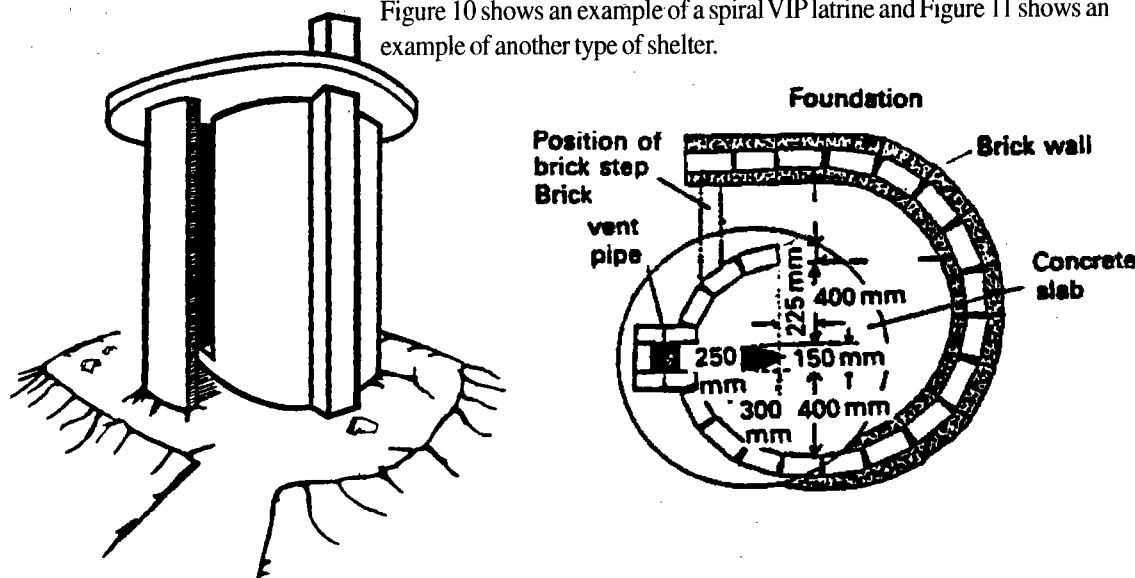
Thin-walled, dark coloured vent pipes, with a minimum internal diameter of 100 millimetres, are the best type of vent pipe. Suitable examples include black painted PVC or fibre-cement. Brick chimneys constructed as part of the shelter will also work adequately, provided the internal walls are made smooth and internal measurements are not less than 225 millimetres by 225 millimetres. A pipe made from cement-plastered hessian sacking, with a chicken wire frame, with a 200 to 250 millimetre internal diameter or cement-plastered split bamboo or reeds may also be used as vent pipes.

The vent pipe should have a fly screen on the top opening to prevent access to insects. Most metal screens are destroyed quickly because the gases coming up the pipe from the pit are very corrosive, although aluminium, copper or stainless steel screens do work well. PVC-coated glass fibre mesh can be used, but will not last more than five years. The openings in the screen should not be smaller than 1.2 millimetres by 1.5 millimetres so that the air flow is not blocked.

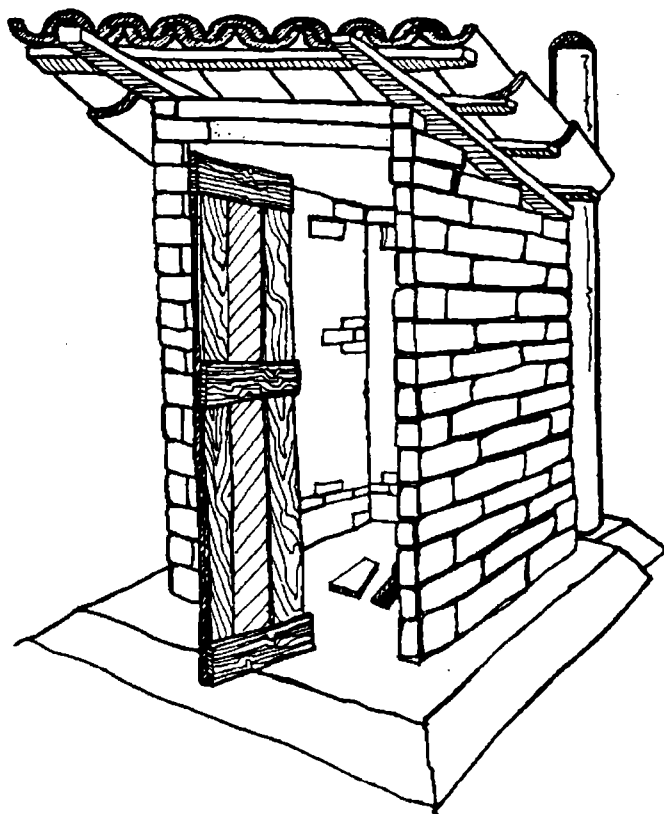
---

### *The shelter*

To give the best fly control, the inside of the shelter should be as dark as possible. The shelter must also provide a free throughflow of air, which is required for odour removal. One way of achieving this is to construct a spiral shelter with no door, so that just sufficient light comes in from the entrance for users to see by, whilst allowing a free throughflow of air into the shelter and pit. Figure 10 shows an example of a spiral VIP latrine and Figure 11 shows an example of another type of shelter.



**Figure 10. Spiral VIP latrine shelter**



**Figure 11. Latrine shelter**

If a door is used on the shelter, it must be kept closed to ensure that the interior of the shelter is kept as dark as possible.

### *Use and care of the VIP latrine*

VIP latrines require a minimum level of day-to-day operation and maintenance :

- The most important aspect is cleanliness. A latrine which is dirty and soiled with excreta will soon be abandoned. The cover slab and squat-hole must be cleaned daily using water or ashes.
- Grass or plants growing around the latrine should be kept well cut.
- Cracks in the cover slab or foundation and holes in the mound which lead directly into the pit should be filled.
- The squat-hole or raised seat must be kept open, as covers prevent the circulation of air which is essential for fly and odour control.
- The fly screen must be regularly checked for damage and replaced if necessary. It should also be cleaned every month by pouring a small amount of water down through the vent pipe to clear away cobwebs and dead flies which may block the air flow and the entry of sunlight.

### **Fact Sheet 3.5**

- Do not deposit tins, glass or plastic inside the pit.
- To stop mosquitoes breeding in pits, the pits should be kept as dry as possible. If too much water has got in, ashes or dry horse or cow dung thrown into the pit every week helps to absorb water and odours.
- No disinfectant should be added to the pit.
- When the pit is full, that is when the contents reach a level of 0.5 metres from the squatting plate, the pit must be filled in with soil. In areas where excreta are used as a fertilizer, the pit should be left for two years before the contents are safe to handle.
- During an epidemic, the floor of the latrine should be cleaned with a disinfectant such as bleach (sodium hy-



# Pour flush latrines

Pour flush latrines use a pit for excreta disposal and have a special pan which is cast in the floor slab and provides a water seal of 20-30 millimetres. This ensures that smells cannot escape into the shelter. Sometimes a vent pipe, which should have a fly screen, is fitted to the pit. The pit may be below or offset from the shelter. Pour flush latrines can also be installed with the pan in the house and the pit outside.

Pour flush latrines require between one and three litres of water for flushing each time they are used, although ideally more should be used.

Once the excreta have been flushed into the pit, the liquids will filter into the ground. Some of the solids will decompose and filter into the ground ; others will remain in the pit.

Eventually the pit will fill with excreta and a new pit will have to be dug. Because the pit cannot be seen from inside the shelter, an inspection cover is needed. Once the contents of the pit reach 0.5 metres from the top of the pit, the pit is filled with earth and a new pit is dug.

The advantages of a pour flush latrine are that there are no fly or smell problems, making these latrines hygienic and pleasant to use, and maintenance is relatively straightforward. If pour flush latrines are not used properly, however, there is a risk of disease transmission.

Water is needed for their operation and they are more expensive than simple pit latrines or VIP latrines, but are still low cost. They are most appropriate where enough water for flushing is easily available and where the ground is permeable. Pour flush latrines are not appropriate for very cold areas where the water seal might freeze. Two examples of pour flush latrines are shown in Figure 1.

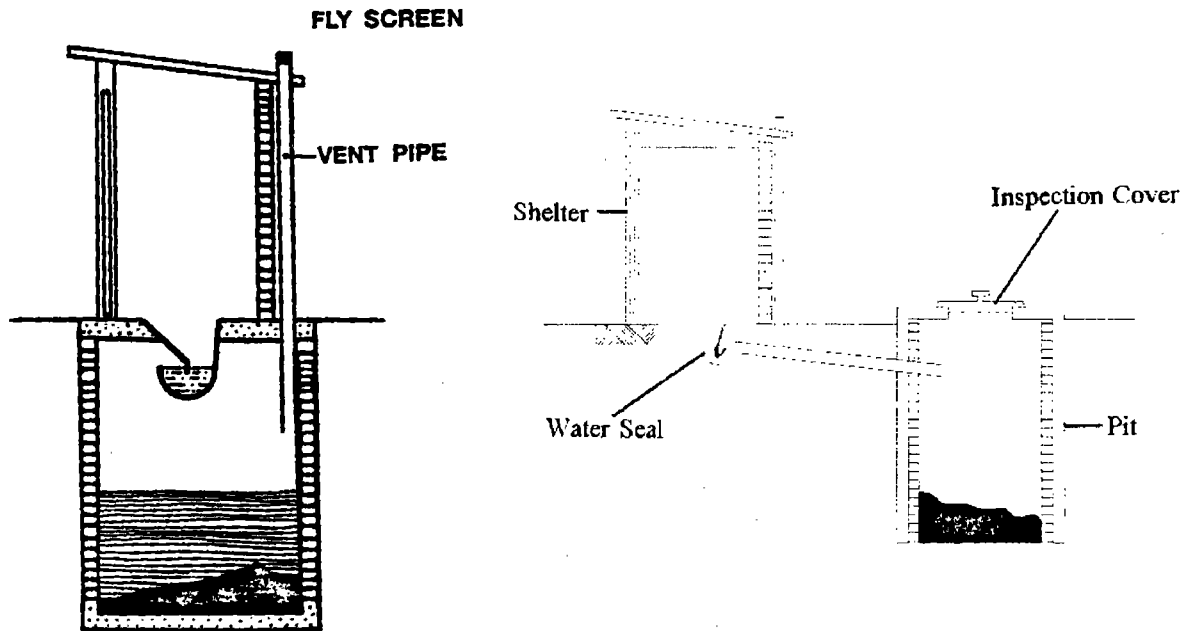


Figure 1. Pour flush latrines - shelter over pit and offset pit

### When is a pour flush latrine appropriate ?

The water added to a pour flush latrine and the liquid part of excreta must infiltrate into the soil. Some soils are permeable and wastewater can infiltrate quickly ; these are appropriate for pour flush latrines. Other soils are not permeable and pour flush latrines should not be built on them. If soils are very permeable, however, there is a risk of groundwater contamination from soakaways, particularly where the water table is high. In these circumstances, the appropriateness of pour flush latrines will depend on whether groundwater sources are used for drinking water.

The permeability of soil can be assessed by measuring the percolation rate, as described below :

- Bore at least six holes of 100 millimetres diameter, ideally to the proposed depth of the latrine pit, or at least 1 metre deep over the area proposed.
- Add about 50 millimetres of gravel to the bottom of each hole (to protect the bottom).
- Fill all the holes with water and leave overnight (to allow the soil to become saturated).
- Refill the holes with water to about 15 centimetres above the gravel.
- Measure the fall in water in millimetres after 30 minutes.
- Calculate the percolation rate, as follows :  

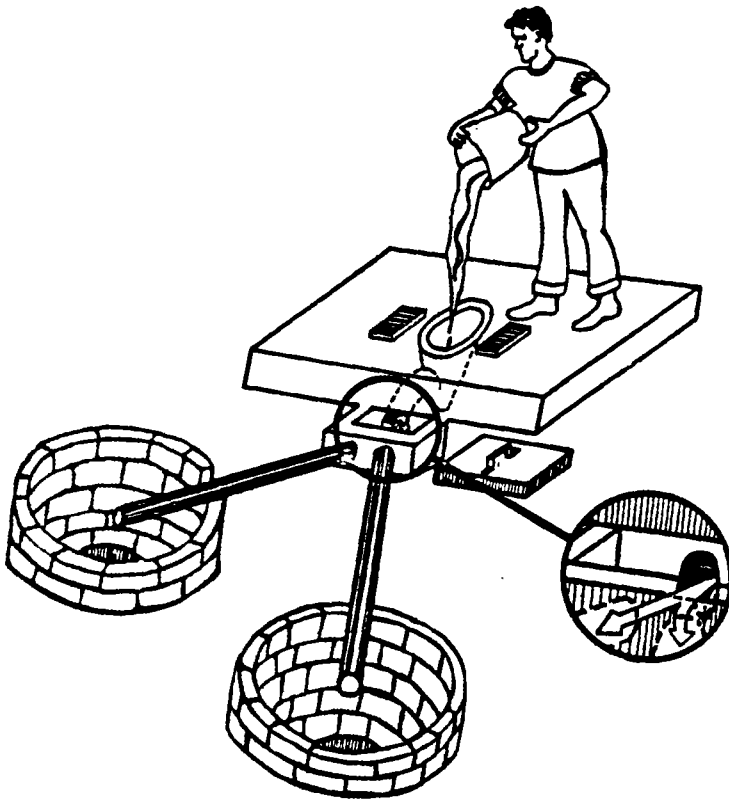
$$\text{percolation rate} = \frac{\text{water level drop} \times 60}{\text{mm/h}}$$

If the percolation rate is 15 mm/h or more, then it is usually considered that the soil has sufficient percolative capacity for a pour flush latrine soakaway or drainfield to be constructed. When the soil has a percolation rate of below 15 mm/h, then excreta disposal options which do not require seepage pits or drainfields should be sought. Where marginal results are gained, local experience may indicate the appropriateness of these technologies.

## *Double pit pour flush latrine*

If two pits are dug and a pipe laid to each pit from the latrine pan, when one pit is full the second pit can be used (see Figure 2).

A junction box with an inspection cover should be built where the pipe divides into two. A stone or a brick can be used to block the exit to one pit so that only one pit fills at a time.



**Figure 2. Double pit latrine (the covers to the pits and the shelter are not shown)**

The full pit should be left for at least two years, after which the excreta can be dug out and used as soil conditioner. Excreta contains many germs, but these die if the excreta is left in the pit for two years or more. Provided that the area is well-drained, the excreta also become dry and odourless.

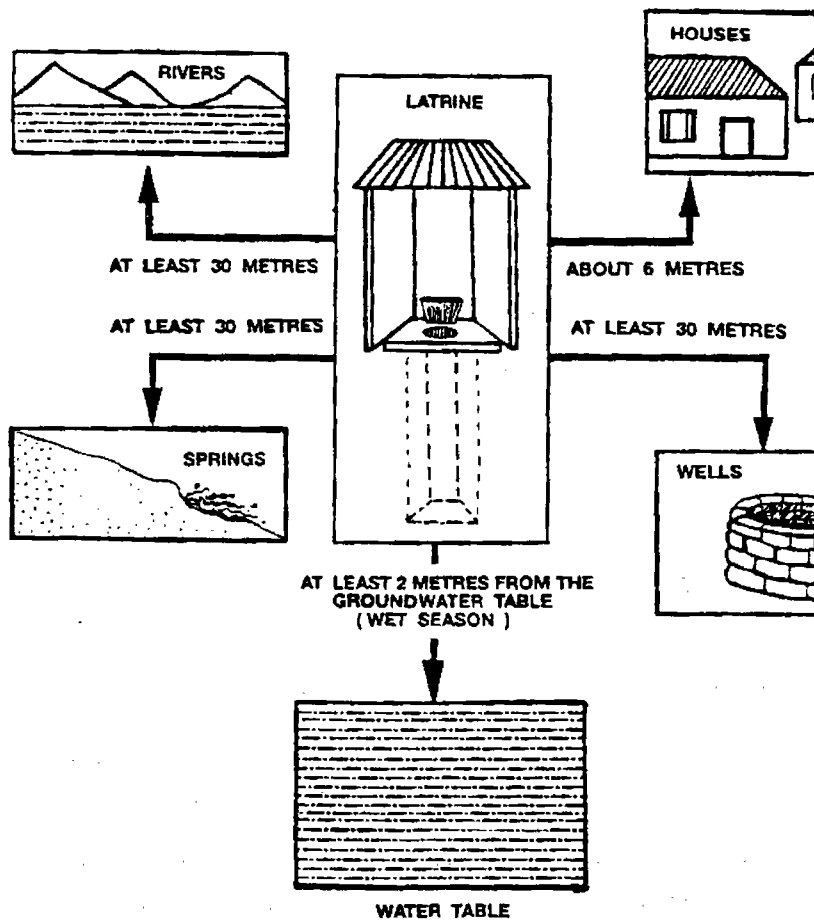
Where there is a demand for excreta as fertilizer or soil conditioner, there are obvious advantages to the double pit arrangement. Similarly, if space is very limited and the same pits must be reused many times, then this arrangement ensures that the excreta become safer to handle before being dug out. This arrangement, however, has disadvantages: most importantly, the junction box may block frequently and requires regular cleaning.

## Where to build a pour flush latrine

When planning to build a latrine, a site should be chosen which is :

- Downhill and the minimum safe distance from the nearest drinking water source. This is site specific and should be determined for all groundwater sources based on local hydrological and hydrogeological conditions. A distance of 30 metres has been suggested by some workers as standard practice. It is recommended that this figure is taken as a guide to establishing a minimum safe distance, in the absence of local information.
- Near to and down-wind from the house, with the entrance facing the house.
- On slightly raised ground, so that rainwater can drain away easily.

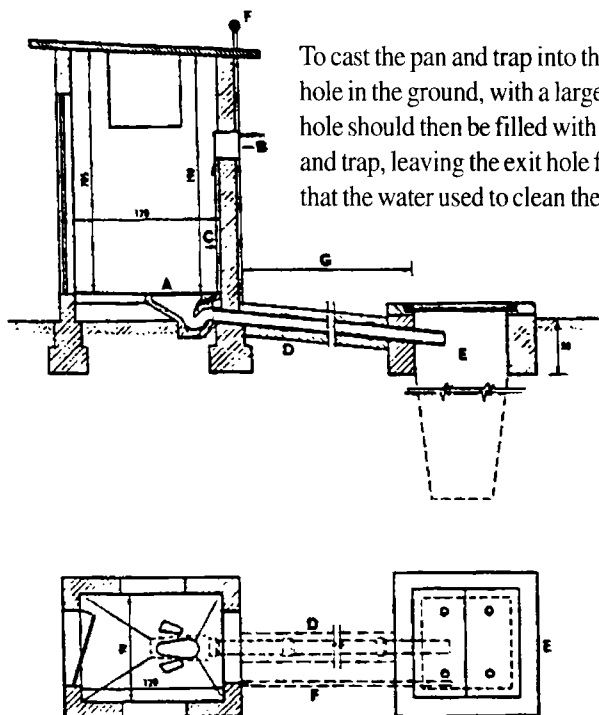
Pour flush latrines should only be built in soil which is permeable and can absorb the water from the pit. Figure 3 indicates some criteria to select the best place to build a pour flush latrine.



**Figure 3. Where to build a pour flush latrine**

## Pan and water trap

The pan and water trap are fixed in the cover slab. They can be bought as a ceramic or PVC unit or made from ferro-cement or fibreglass. Ready-made units are generally stronger, lighter and easier to clean, although ferro-cement pans can be as effective. Details of the pan and trap are shown in Figure 4.



- A= WATER-SEAL BOWL WITH S TRAP.**  
**B= WATER TANK, FILLED BY HAND AND PROVIDED WITH PLUG COCK AND OVERFLOW PIPE.**  
**C= WATER PIPE LEADING FROM TANK TO BOWL FOR FLUSHING PURPOSES.**  
**D= DRAIN PIPE EMBEDDED IN CONCRETE LEADING TO SEEPAGE PIT.**  
**E= SEEPAGE PIT.**  
**F= VENTILATION PIPE FOR PIT.**  
**G= DISTANCE BETWEEN BOWL AND PIT SHOULD BE AS SHORT AS POSSIBLE.**

**Figure 4. Section through a pour flush latrine showing the pan and trap**

The pan and trap of a pour flush latrine can be built inside the house if the pit is built outside and the vent pipe from the pit rises higher than the roof of the house.

## The pit

The pit for a pour flush latrine can be either directly below the pan and trap or several metres away. The pit should always be built as follows :

- The pit should not be dug down into the groundwater.

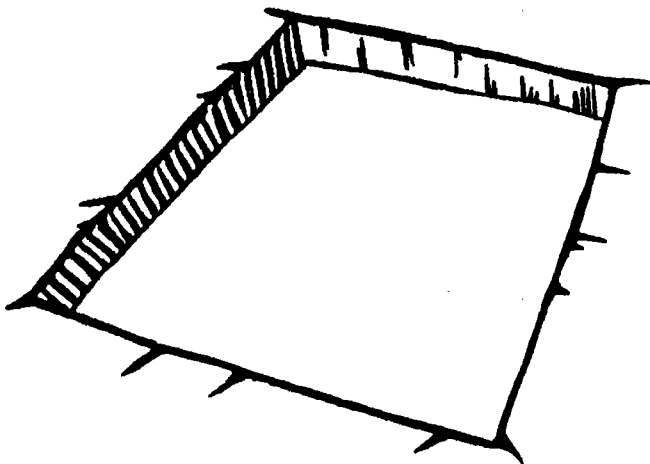
- The pit should be as deep as possible, at least 1.5 metres, with vertical sides and 1 to 1.2 metres in diameter. Circular pits will provide greater strength, but are more difficult to construct than square pits. The inlet pipe from the pan should enter the pit about 250 millimetres below ground level.
- The pit should be lined to stop the walls collapsing. The walls can be washed away gradually by the water in the pit if they are not protected by a brick or stone lining. A wide range of materials can be used to line the pit, as indicated in Fact Sheet 3.4. Examples include blocks, bricks, cement-stabilized soil blocks, masonry, stone rubble, perforated oil drums and rot-resistant timber. The lower part of the lining should be built with spaces between the bricks or stones to allow water to seep into the ground from the pit. The floor of the pit should be left as bare earth.
- For the double pit latrine, both pits should be of the same size as the single pit described above and lined. The pits should be the depth of the pit apart.

---

### *The cover slab*

To construct a simple reinforced concrete cover slab :

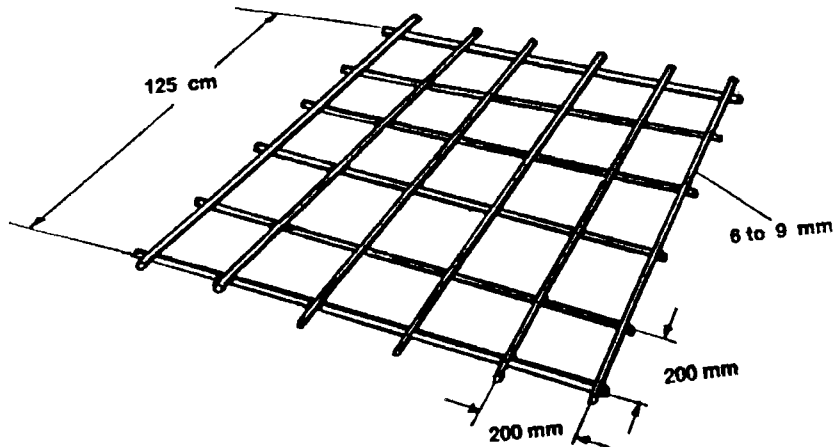
- Dig a square, shallow pit, about 200 millimetres wider and longer than the pit and 50 millimetres deep. Be sure that the bottom of the pit is level and smooth (see Figure 5).



---

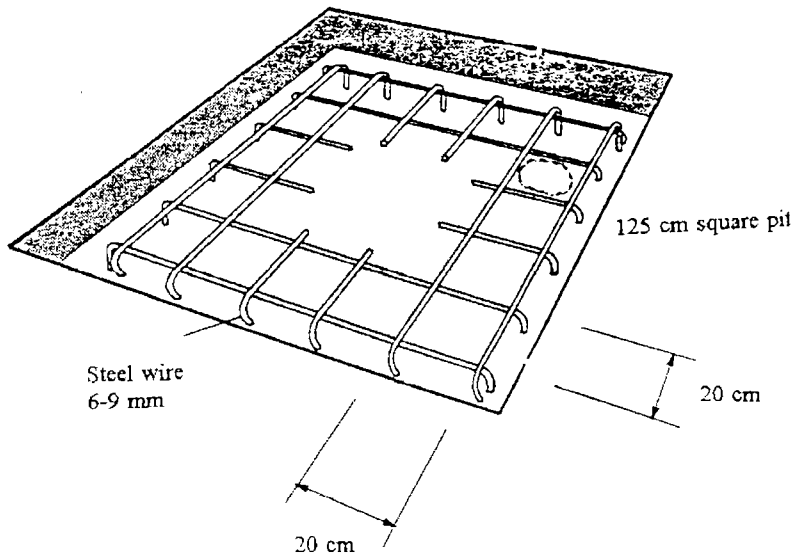
**Figure 5. Preparing a pit for cover slab casting**

- Make or cut a wire mesh or grid to lie inside the pit. The wires can be 6 to 9 millimetres thick and about 200 millimetres apart (see Figure 6). Cut a hole about 250 millimetres in diameter in the middle of the grid.

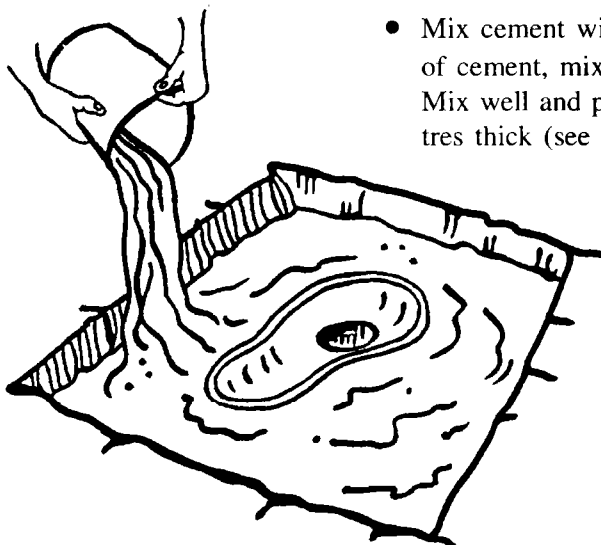


**Figure 6. Reinforcement grid**

- Put the grid in the pit. Bend the ends of the wires, or put a small stone at each corner, so that the grid stands about 20-30 millimetres off the bottom of the pit (see Figure 7). Put the pan and water trap in the hole in the grid.



**Figure 7. Laying the grid in the pit**



- Mix cement with sand, gravel and water (with each shovel of cement, mix 2 shovels of sand and 4 shovels of gravel). Mix well and pour it into the pit until it is about 5 millimetres thick (see Figure 8).

**Figure 8. Laying the slab**

- Cover the concrete with damp cloths, cement bags, sand, hay or a sheet of plastic and keep it damp. It is important that the concrete is kept damp for five days to reach its full strength. Remove the slab after five days.

---

### *The waste pipe*

A waste pipe is needed if the pit is offset and not directly below the cover slab. The waste pipe running from the pan and trap to an offset pit should be connected using cement or a sealing compound. The waste pipe should be placed on a slope of 15° to the horizontal. The best type of pipe is PVC. Normally, 100 millimetre diameter pipe is used. The pipe should be buried, as PVC becomes brittle if exposed to the sun for any length of time. The end of the waste pipe should extend at least 100 millimetres into the pit to prevent the liquid damaging the wall of the pit.

---

### *Junction box*

The junction box for a double pit pour flush latrine should be built from brick or concrete, and is connected to the waste pipe running from the latrine and to both pits.

The junction box has two functions :

- To divert the waste flow to either pit. (A stone or brick is used to block one of the exit pipes).
- To allow access to clear any blockages in the waste pipe or the trap.

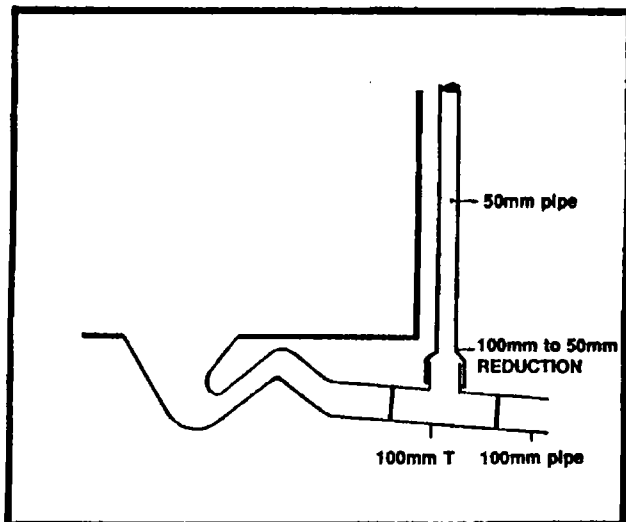
---

### *The vent pipe*

The vent pipe allows gas to escape from the pit and prevents odours coming out through the pan. Vent pipes are not always necessary for pour flush latrines, but should always be used where the pit is offset by some distance from the pan and trap. Pour flush latrine vent pipes should be built using a 50 millimetre PVC pipe, and covered with a fly screen of stainless steel, aluminium or PVC coated fibreglass.

The vent pipe can be attached to the waste pipe just after the pan and trap using a 100 millimetre T and a PVC reduction from the waste pipe size to the 50 millimetre vent pipe size. This is shown in Figure 9.





**Figure 9. Connection for vent pipe**

### *The shelter*

The shelter is for privacy and protects the user and the latrine from the weather. The shelter can be made from any suitable materials. Fact Sheet 3.5 gives some useful recommendations on how to construct shelters.

Water should be kept nearby for flushing (ideally stored alongside or inside the latrine) and a container which holds enough water (1-3 litres per flush) to flush the latrine.

### *Care of the latrine*

- Keep the latrine floor clean ; clean daily using water.
- Check the depth of the solids in the pit occasionally. When the solids reach a level of 0.5 metres from the surface, then the contents of the pit should be covered over with soil. If there is a single pit, then a new pit should be dug. If there are two pits, the flow through the junction box should be changed so that the latrine flushes into the second pit. When the second pit is full, the first pit should be dug out and the flow redirected into it.
- During an epidemic, the floor of the latrine should be cleaned daily with disinfectant, such as bleach (sodium hypochlorite).

# Composting latrines

Composting latrines are shallow vaults, into which kitchen waste and similar materials are added as well as excreta. The waste and excreta break down together to produce a compost which can be dug out and used as fertilizer.

In a composting latrine there are two shallow vaults, only one of which is used at a time. When one is nearly full, it is covered with soil and left for at least two years for the excreta and waste to decompose and for the pathogenic (disease-causing) germs in it to die. While the first vault is closed, the second is used. When the second is nearly full, the first is opened, the compost dug out for use as fertilizer and the first vault re-used.

The vaults must not receive water or become flooded and so they are usually built partially above ground level. Organic waste should be added daily to help the excreta break down. Ash, powdered horse dung, sawdust or similar material should be added after each use. This helps to minimize odours.

The advantages of a composting latrine are that it does not need to be moved and new vaults do not have to be dug. The compost produced is a good fertilizer and soil conditioner, and the latrine also disposes of kitchen waste. Composting latrines are, however, more expensive and more difficult to build than pour flush or VIP latrines. As with all latrines, if they are not used properly then there is a risk of transmission of diseases.

Composting latrines are most appropriate where there is a demand for the compost produced as a fertilizer and soil conditioner. It is essential that any programme supporting construction of composting latrines include a substantial educational component to ensure their proper management and that fresh excreta are not handled and used. A typical composting latrine is shown in Figure 1.

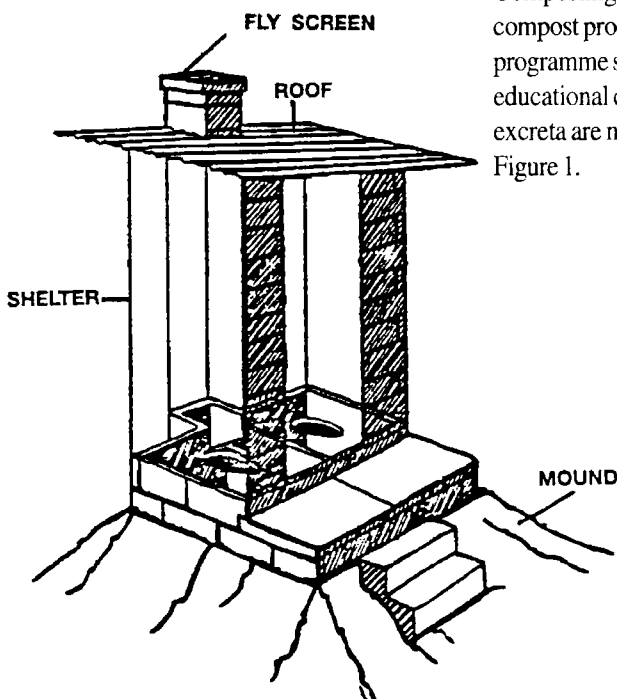


Figure 1. Composting latrine

## Where to build a latrine

When planning to build a latrine, a site should be chosen which is :

- Downhill and the minimum safe distance from the nearest drinking water source. This will be site specific and should be established for each water source based on the local hydrological and hydrogeological conditions. A distance of 30 metres has been suggested by some workers as standard practice. It is recommended that this figure is taken as a guide to establishing a minimum safe distance, in the absence of local information.
- Near to and down-wind from the house, with the entrance facing the house.
- On slightly-raised ground, so that rainwater can drain away easily.

Figure 2 shows where to locate a composting latrine.

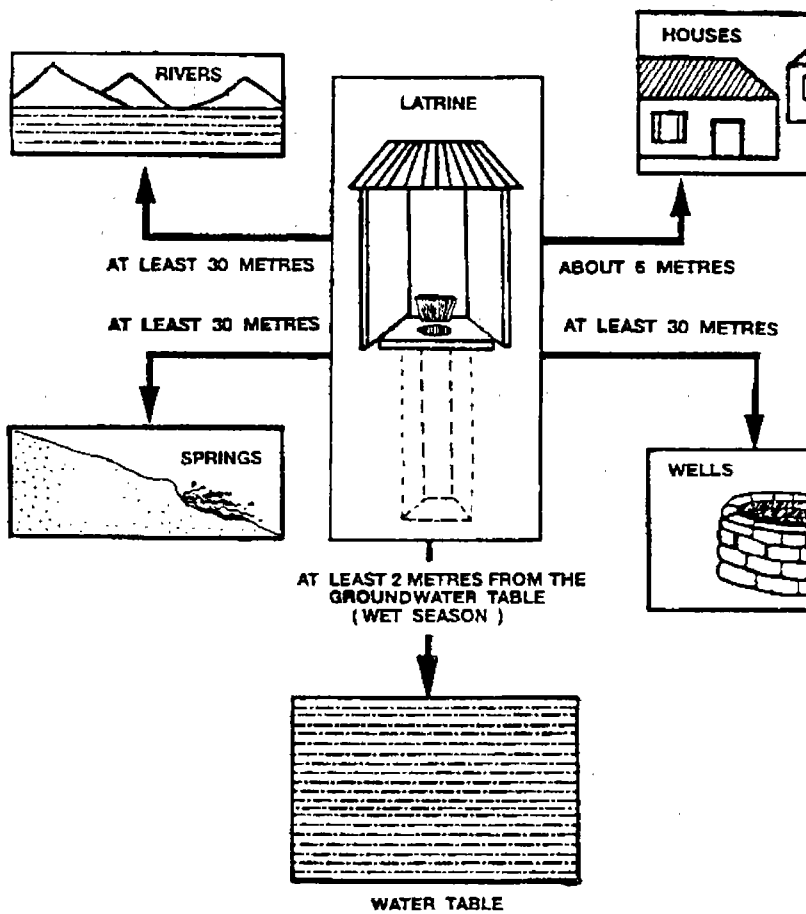


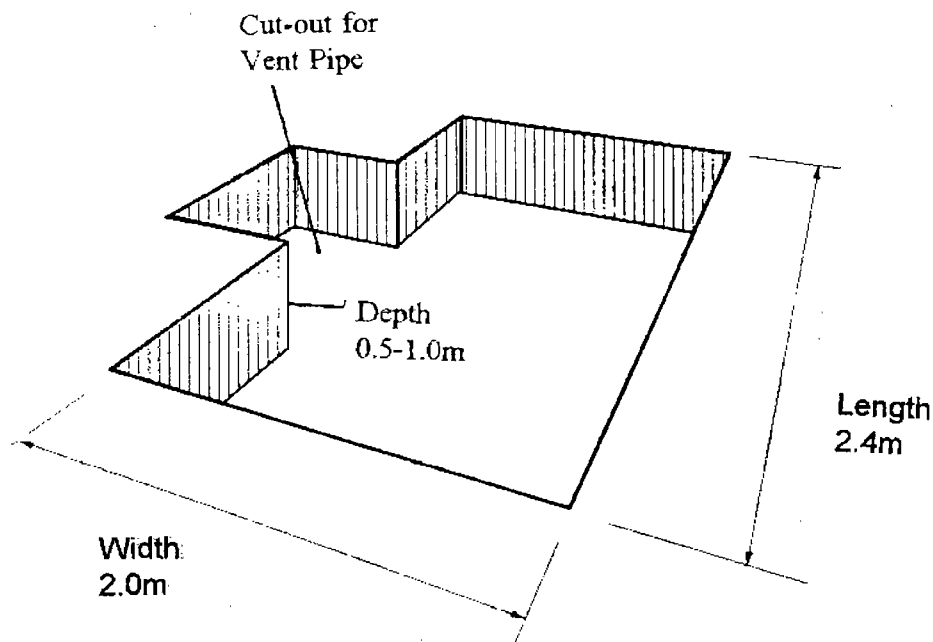
Figure 2. Where to build a latrine

## The vaults

It is very important that the composting latrine vaults are always kept dry. Any water getting into the composting excreta will spoil the compost and cause problems of odour.

If the groundwater level is very close to the surface, the vaults can be made almost completely above ground and can be sealed with cement plaster to stop water seeping in. An example of how to build the vaults is detailed below and should be adapted to local circumstances and materials.

- Dig a hole 2.0 metres by 2.4 metres and 0.5 metres deep, with space for the vent pipe (see Figure 3). If water appears in the pit, then it can be made less deep.



**Figure 3. Pit for a composting latrine**

- If the ground is very wet, build the vaults on a mound to keep them above water. In this case, the latrine vault needs a cement base to keep it waterproof.
- Position a timber framework for the base. The framework should be 1.5 metres by 1.8 metres. The concrete needs to be 50 millimetres to 70 millimetres thick. Mix the concrete : one shovelful of cement, two shovelfuls of sand and four shovelfuls of gravel. Pour the concrete into the framework until it is about 50 millimetres deep (see Figure 4). Cover the concrete with used cement bags or grass and keep damp for 5 days until the concrete is fully hardened. If the groundwater level is well below the bottom of the vaults, there is no need for a concrete floor.

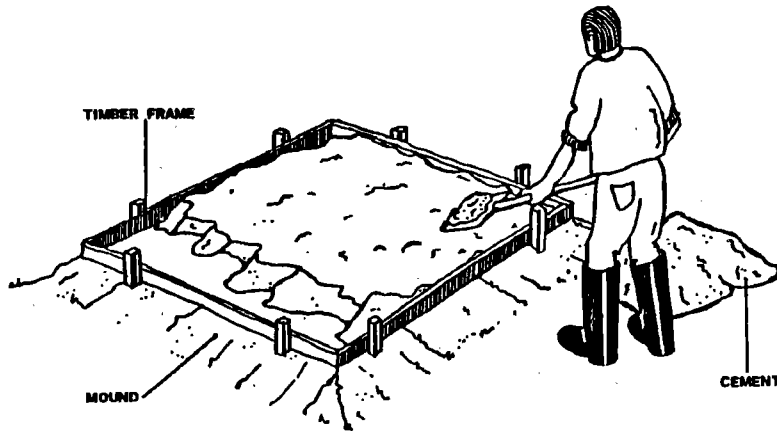


Figure 4. Cement floor for raised vaults

- Build the walls of fired bricks or cement blocks and cement mortar up to 0.8 metres high. Build a dividing wall for the two vaults and the base for the vent pipe, which should be at least 250 millimetres square to allow good air flow (see Figure 5).

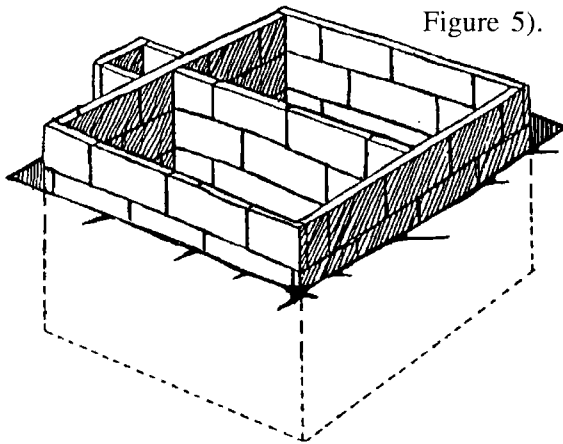


Figure 5. Composting latrine vaults

- Build a concrete support beam 0.8 metres from the back of the vaults across the dividing wall. Support the beam with timber while the cement hardens well. Add another layer of blocks or two layers of bricks to the walls of the vaults (see Figure 6).

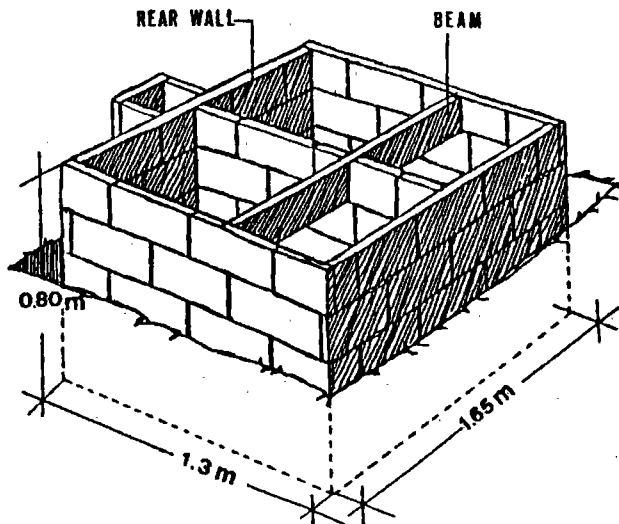
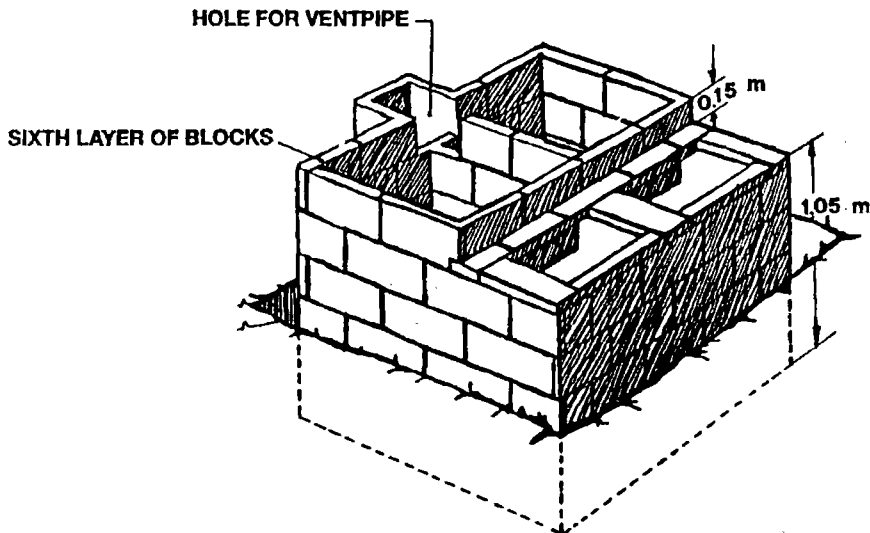


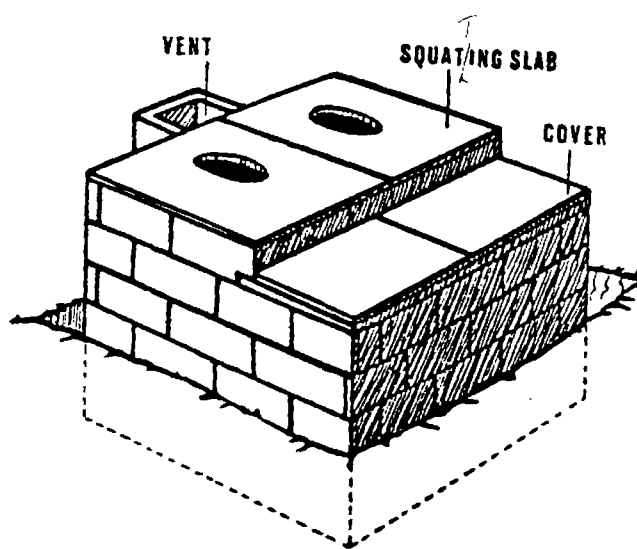
Figure 6. Support beam

- Lay flat bricks or blocks around the front part of the two vaults to form a ledge to support the vault covers which give access to allow for the removal of the compost. Then build a final layer of blocks or two layers of bricks around the rear part of the vaults and the vent pipe. Leave a gap between the vent pipe and the vaults, to allow odours to pass up the vent pipe (see Figure 7).



**Figure 7. Cover supports**

Note that the total depth of the vaults is about 1.05 metres below the vault covers and 1.2 metres below the latrine slabs (see Figure 8).



**Figure 8. Finished vaults**

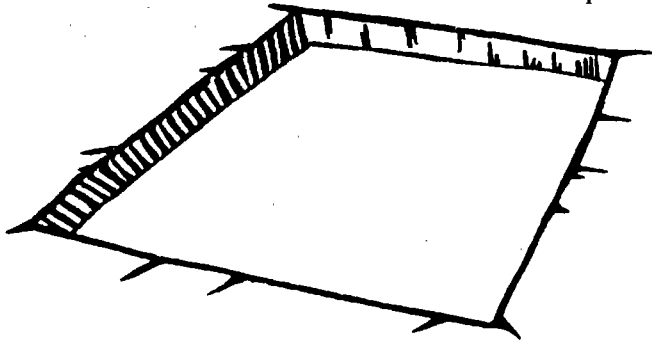
The squatting slabs support the user and cover the pit. The slabs should be big enough to cover the vaults without leaving any spaces for flies or vermin to get in. Two squatting slabs are needed to cover the vaults and two covers are required to allow for the removal of compost.

Both the squatting slabs and the covers are made from reinforced cement concrete.

Instructions for making a simple squatting slab are presented below.

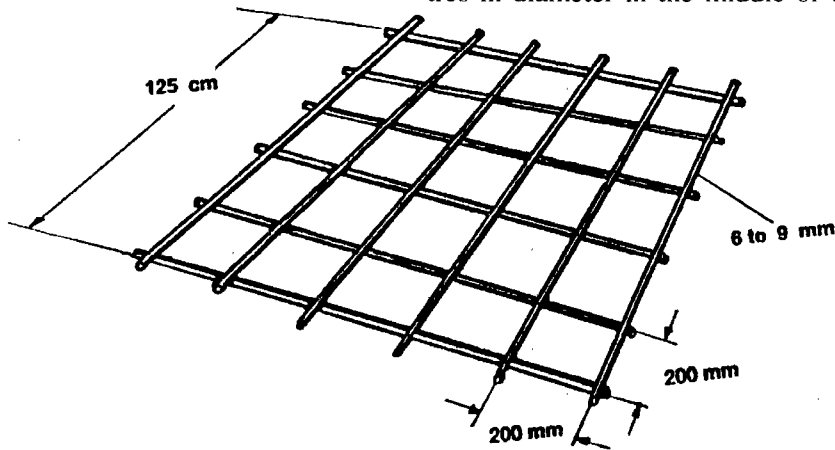
To construct a simple reinforced concrete covering slab :

- Dig a square, shallow pit, about 200 millimetres wider and longer than the pit and 50 millimetres deep. Be sure that the bottom of the pit is level and smooth (see Figure 9).



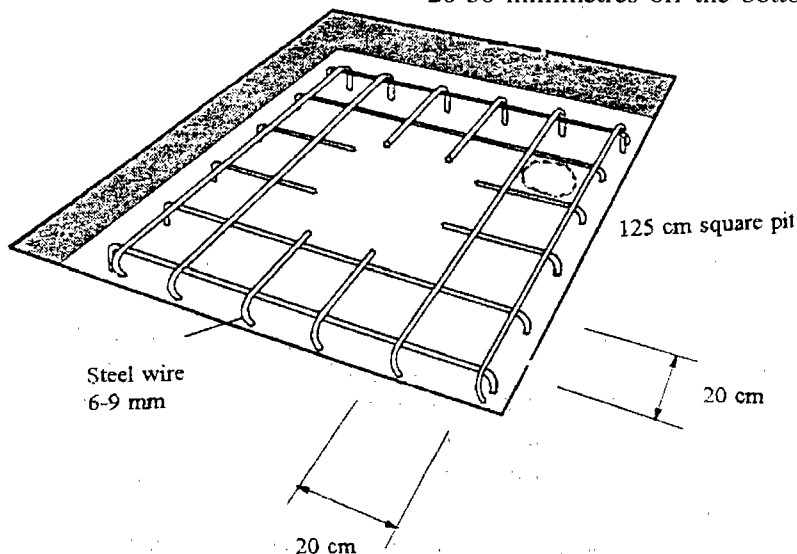
**Figure 9. Preparing a pit for cover slab casting**

- Make or cut a wire mesh or grid to lie inside the pit. The wires can be 6 to 9 millimetres thick and about 200 millimetres apart (see Figure 10). Cut a hole about 250 millimetres in diameter in the middle of the grid.



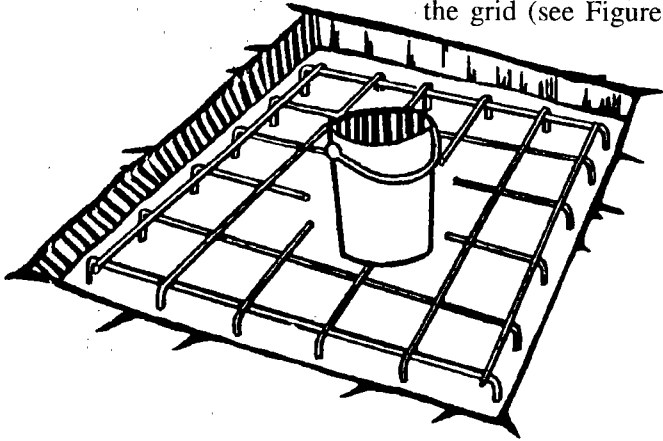
**Figure 10. Reinforcement grid**

- Put the grid in the pit. Bend the ends of the wires, or put a small stone at each corner, so that the grid stands about 20-30 millimetres off the bottom of the pit (see Figure 11).



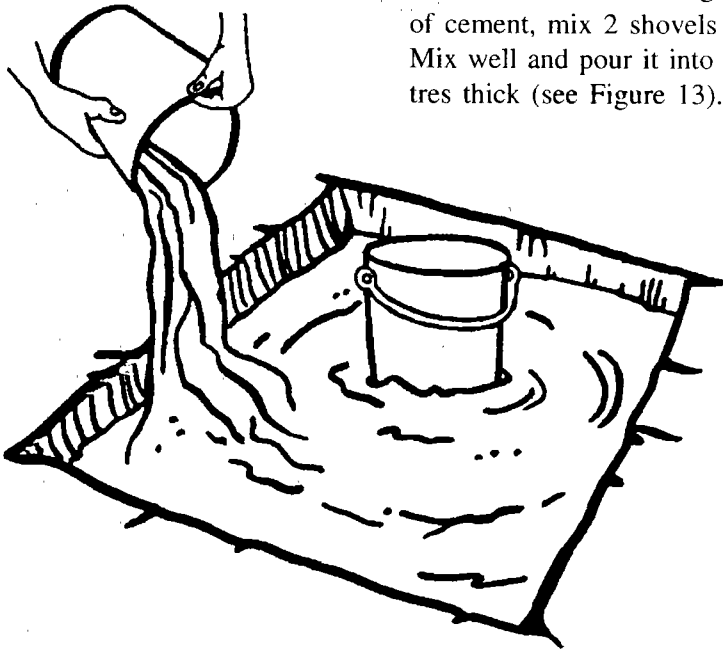
**Figure 11. Laying the grid in the pit**

- Put an old bucket with a bottom about 200 millimetres across or a template in the shape of a keyhole in the hole in the grid (see Figure 12).



**Figure 12. Making a squat hole**

- Mix cement with sand, gravel and water (with each shovel of cement, mix 2 shovels of sand and 4 shovels of gravel). Mix well and pour it into the pit until it is about 50 millimetres thick (see Figure 13).



**Figure 13. Laying the slab**

- Remove the bucket when the cement is beginning to harden (after about three hours). Then cover the cement with damp cloths, cement bags, sand, hay or a sheet of plastic and keep it damp. It is important that the cement is kept damp for five days to reach its full strength. Remove the slab after five days.

## *The mound*

The function of the mound is to protect the pit and base from surface water which otherwise might enter and prevent the composting process, as well as damaging the pit. The mound should be built up to the level of the floor and be well tamped. It should extend at least 0.5 metres beyond the base on all sides. In exceptional cases, the mound may be built up considerably above the ground for protection against tides and flood waters.



The mound will normally be built with the earth excavated from the pit or surrounding area, and may be consolidated with a stone facing to prevent it from being washed away by heavy rains. In front of the entrance door, it is a good idea to supplement the mound with a masonry or brick-built step which makes the mound resistant to use.

---

## *The shelter*

The shelter is for privacy and protects the user and the latrine from the weather. The shelter can be made from any suitable materials and is placed on the base of the latrine. The shelter should be high enough for comfort, although the height will depend on the users of the latrine. Openings of 100 to 150 millimetres width should be provided at the top of the shelter walls for constant ventilation.

The roof should cover the shelter completely and have a large overhang to protect the mound and the walls from rain or roof drainage.

---

## *Use and daily maintenance*

Before using the compost latrine for the first time, put a large amount of leaves, grass, weeds, sawdust, horse and cow dung into the vault which is to be used. This will help to absorb odours and liquid.

To make the compost latrine work, organic waste, such as grass clippings, leaves, sawdust, and fruit and vegetable peelings, must be put into the latrine every day or at least once a week. These help the excreta to break down more quickly, stop odours and also make better compost. After each use, material such as ash, powdered horse or cow dung or sawdust should be thrown into the latrine to absorb odours. A sack of this material with a scoop should be left in the compost latrine shelter ready for use after defecation.

Once the vault in use is nearly full (about 0.5 metres below the squatting plate), the vault should be sealed and the second vault opened. The full vault should be left closed for at least two years to allow the compost to form. A cover should be placed over the hole in the slab of the vault not in use to prevent people using it.

Any grass or plants growing around the latrine should be kept well cut. Do not put cans, glass or plastic bottles into the compost latrine. These will not break down and will fill the compost latrine up more quickly. The cover slab and squat hole should be cleaned daily, for example with ashes.

During an epidemic, the floor and lid of the latrine should be cleaned daily with a disinfectant such as bleach (sodium hypochlorite).

---

## *Use of excreta as fertilizer*

After at least two years, the excreta can be dug out of the first pit and used as fertilizer. Fresh excreta contain many germs, but these die if the excreta are left in the pit for two years or more. Provided that no water is allowed to get into the pit, the excreta also become dry and odourless. To allow the composted excreta to break down completely in the soil, the compost should be buried in trenches and covered over with soil.

---

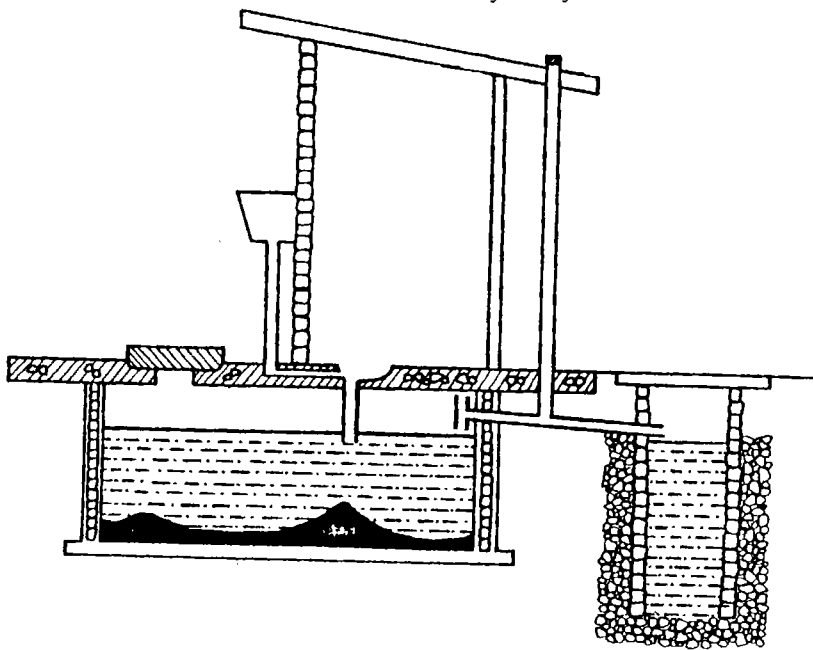
## *Care of the latrine*

A composting latrine can be pleasant to use and help to prevent the spread of infectious diarrhoeal diseases such as cholera, but only if it is kept clean. Clean the latrine floor daily with a brush (which should be kept in the latrine and used only for this purpose) and ashes, corn husks or similar materials.

# Aquaprivies

An aquaprivy is a tank filled with water into which excreta fall via a drop pipe. Aquaprivies use a simple water seal to prevent odours getting out of the tank and have a soakaway to dispose of sullage and effluent. It is important that the drop pipe reaches below the surface of the water in the tank to prevent the escape of odours. The tank should be watertight to prevent pollution of groundwater and requires emptying about every three years. An example of an aquaprivy is shown in Figure 1.

The advantages of aquaprivies are : they cannot be blocked with bulky anal cleansing material ; there should be few problems with odour or flies ; and they can be connected to sewerage systems at a later date. The disadvantages are : they are expensive to build ; they need large volumes of water to work ; the water seal can be hard to maintain where water cannot be added daily, or in cold areas where the water seal may freeze ; and the tank must be emptied about every three years.



**Figure 1. The aquaprivy**

## *Where is an aquaprivy appropriate ?*

Aquaprivies produce liquid effluent which must be disposed of by infiltration into the ground. The liquid effluent contains large numbers of germs which are dangerous. It is important that the effluent is only disposed of by infiltration ; aquaprivies should therefore only be built where the soil is permeable and the effluent produced can infiltrate into the soil. Where soils are very permeable, however, there is a risk of groundwater contamination, particularly where the water table is high.

The permeability of soil can be assessed by measuring the percolation rate, as described in Fact Sheet 3.6. If the percolation rate is 15 mm/h or more, then it is usually considered that the soil has sufficient percolative capacity for an aquaprivy soakaway or drainfield to be constructed. When the soil has a percolation rate of below 15 mm/h, then excreta disposal options which do not require soakaways or drainfields should be sought. Where results are marginal, local experience may indicate the appropriateness of these technologies.

---

### *Where to build an aquaprivy*

The aquaprivy should preferably be built downwind of the house to make sure that odours are not carried into the house.

The aquaprivy should be :

- Downhill and the minimum safe distance from any drinking water source. This is site specific and should be determined for each water source on the basis of local hydrogeological conditions. A distance of 30 metres has been suggested by some workers as standard practice. It is recommended that this

figure is taken as a guide to establishing a minimum safe distance, in the absence of local information.

The seepage pit should be :

- Downhill and the minimum safe distance from any drinking water source.
- At least 3 metres from the aquaprivy.

---

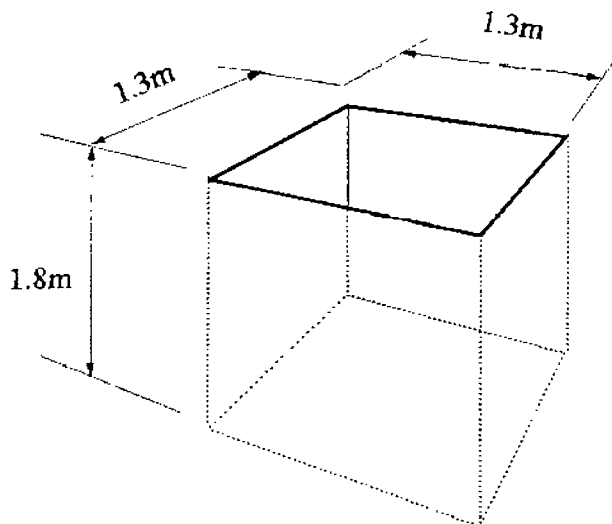
### *The tank*

The tank for an aquaprivy is directly below the cover slab. The tank should be about one metre square and 1.6 metres deep.

The tank should be lined to make it watertight, so preventing leakage of water and the breaking of the water seal. Suitable lining materials include, for instance, mortared brickwork which is plastered with a cement-rich mortar to ensure impermeability. It is, however, likely that some of the water in the aquaprivy tank will be lost each day through leakage, and it is therefore important to add some water daily, usually only one or two bucketfuls.

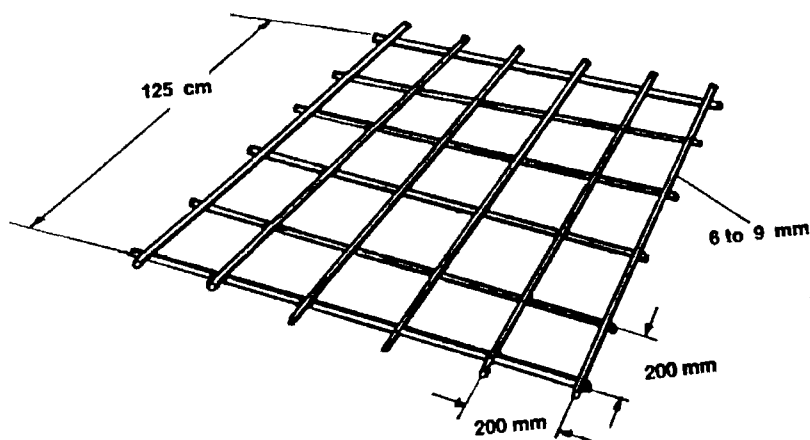
Construct the tank as follows :

- Dig the hole for the aquaprivy tank. Add 300 millimetres to the dimensions of the tank to allow for the walls and working space. The hole should therefore be 1.3 metres square and 1.8 metres deep (see Figure 2).



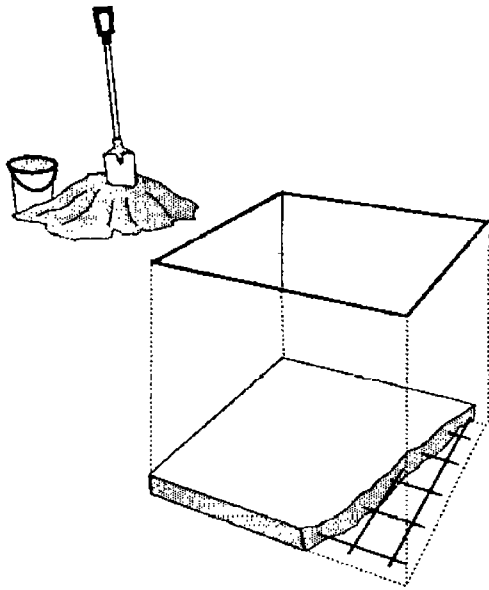
**Figure 2. The pit for the aquaprivy tank**

- Level and compact down the bottom of the pit.
- Make a grid for the floor of 6 to 9 millimetre iron reinforcing rods set 200 millimetres apart (see Figure 3).



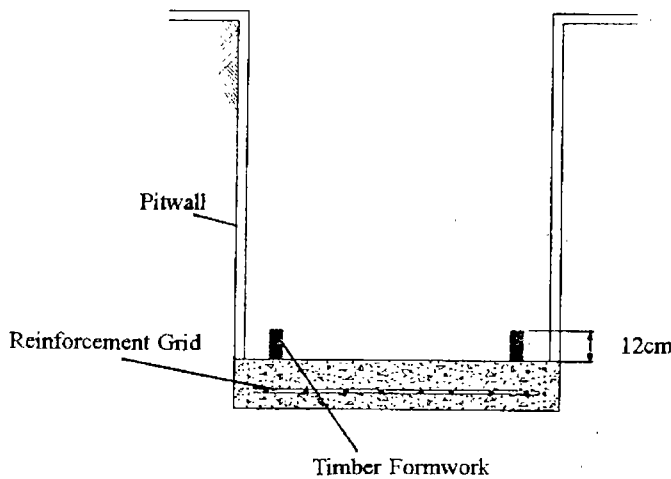
**Figure 3. The reinforcing grid**

- Support the grid on four small stones, one in each corner, to lift the grid 20-30 millimetres off the bottom.
- Mix cement concrete (1 shovelful of cement, 2 shovelfuls of sand and 4 shovelfuls of gravel, with water) and pour the concrete into the bottom of the hole to form a floor about 50 millimetres thick. The reinforcing grid should be in the middle of the concrete layer (see Figure 4).



**Figure 4. Laying the floor**

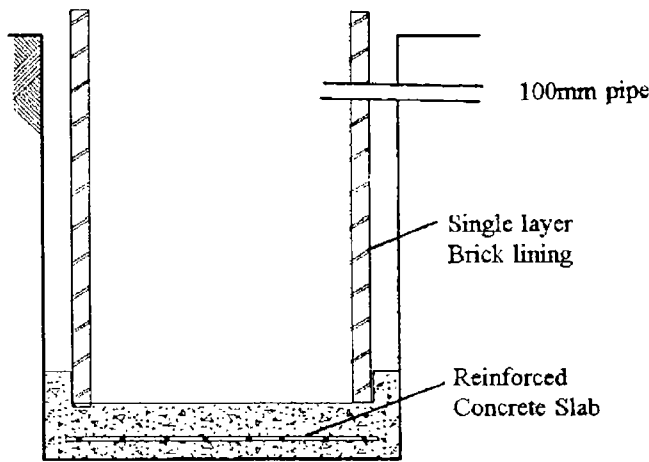
- When the floor has set for 3 hours, place the formwork 100 millimetres inside the edge of the floor (see Figure 5).



**Figure 5. Placing the formwork**

- Pour more concrete into the space between the formwork and the walls of the hole. This will form a lip on the edge of the floor.
- Cover the concrete floor and lip with old cement bags or grass, and leave to set for at least 5 days keeping the concrete damp to allow it to develop its full strength. Remove the timber formwork.
- Use well-fired bricks or concrete blocks to build the walls, and a cement mortar of one shovelful of cement and three shovelfuls of fine sand mixed with water. Build the walls inside and mortared up against the lip on the bottom.

- When the rear wall reaches 150 millimetres from the ground surface, place the outlet pipe (a length of 100 millimetres diameter PVC pipe) in the wall. Build the rest of the wall around the outlet pipe. Figure 6 shows the pit with lip, walls and outlet pipe in place.



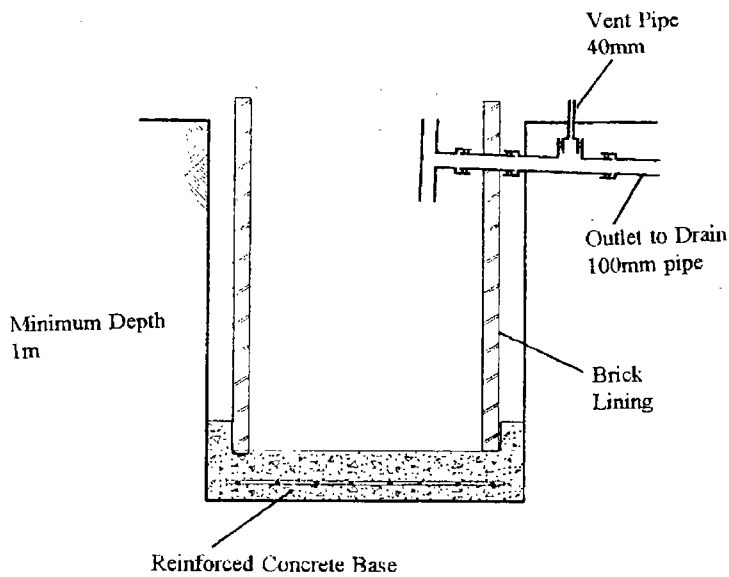
**Figure 6. Aquaprivy pit**

- To make sure that the tank is watertight, the inside of the tank must be plastered with a thin layer of a rich cement mortar using one shovelful of cement and two shovelfuls of fine sand mixed with water.
- Keep the tank covered and moist for five days until the cement plaster has set, then fill the tank with water to check the overflow and the watertightness of the plaster. Leave the tank full of water overnight to check leakage. Fill in the space around the tank walls with soil and pack down.

## Finishing the pipework

The vent pipe allows gas to escape from the tank and prevents odours entering the shelter. The vent pipe is connected to the outlet pipe. The vent pipe should be built using a 50 millimetre PVC pipe covered with a fly screen of stainless steel, aluminium or PVC-coated fibreglass. The pipe can be attached to the wall of the tank just below the slab.

A "T" is connected to the outlet inside the tank to prevent floating scum blocking the outlet or vent, or being carried out to the seepage pit. The final piping arrangement is shown in Figure 7.

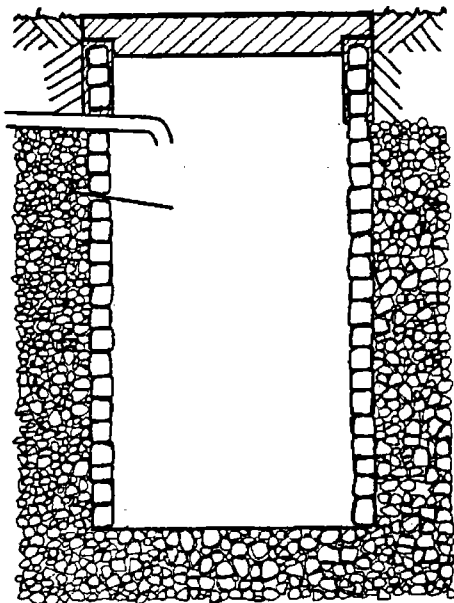


**Figure 7. Aquaprivy pipework**

### *Overflow and soakaway*

The overflow pipe should be laid with a slight slope (1 in 100) towards the soakaway. The soakaway must be at least 3 metres from the tank. For a family of nine people, the soakaway should be about one metre in diameter and two metres deep.

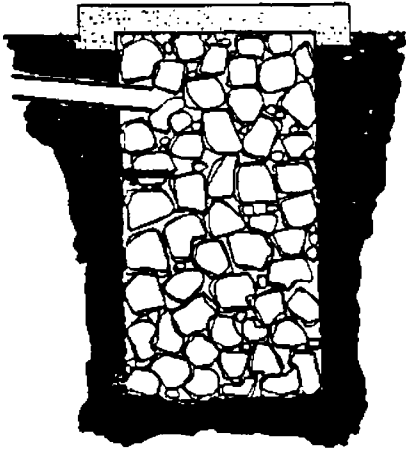
The soakaway can be lined with unmortared brick or stones (see Figure 8).



**Figure 8. Lined soakaway**

Alternatively, the soakaway can be unlined and back-filled with rocks or stone, as shown in Figure 9.



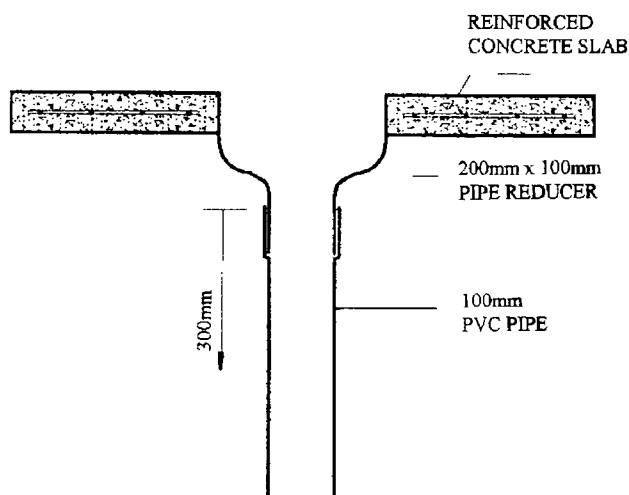


**Figure 9. Unlined, back-filled soakaway**

The soakaway should be covered with a concrete lid or with well-compacted clay or soil to stop flies getting into the pit. A splash plate should also be added to prevent erosion or boring in the soakaway, as well as to distribute the flow.

### *The squatting plate or floor*

The squatting plate for the tank should be made of reinforced concrete and be big enough to cover the tank. The cover slab should have a squat hole into which is set a 200 millimetre to 100 millimetre PVC reducer. A 300 millimetre length of 100 millimetre diameter PVC pipe is then glued to the reducer, as shown in Figure 10.



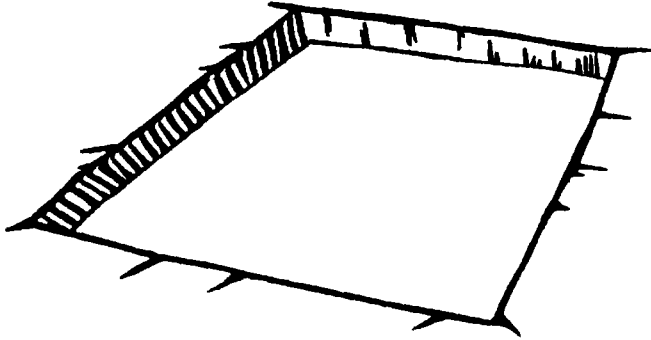
**Figure 10. Cover slab**

Ideally, the squatting plate should have foot rests, as the floor may become slippery. The squatting plate should also have a slope towards the pan to allow good drainage.

To construct a simple reinforced concrete covering slab :

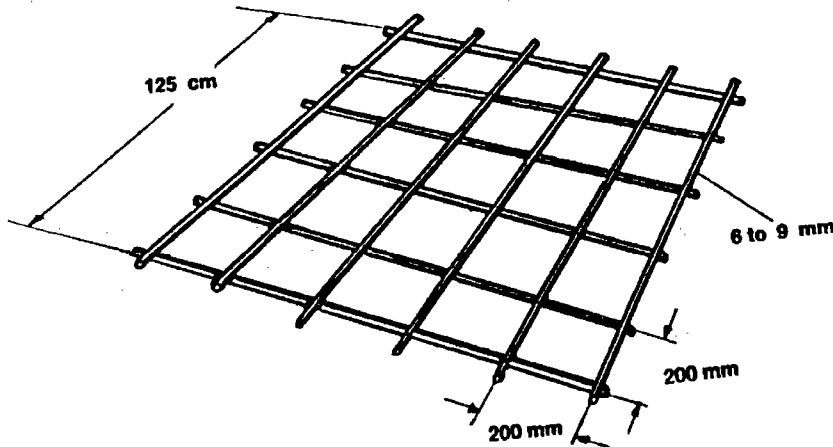
**Fact Sheet 3.8**

- Dig a square, shallow pit, about 200 millimetres wider and longer than the pit and 50 millimetres deep. Be sure that the bottom of the pit is level and smooth (see Figure 11).



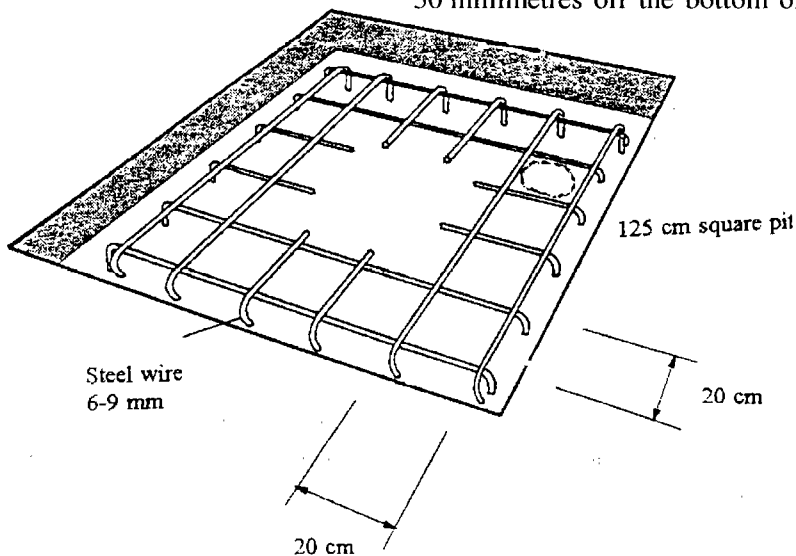
**Figure 11. Preparing a pit for cover slab casting**

- Make or cut a wire mesh or grid to lie inside the pit. The wires can be 6 to 9 millimetres thick and about 200 millimetres apart (see Figure 12). Cut a hole about 250 millimetres in diameter in the middle of the grid.



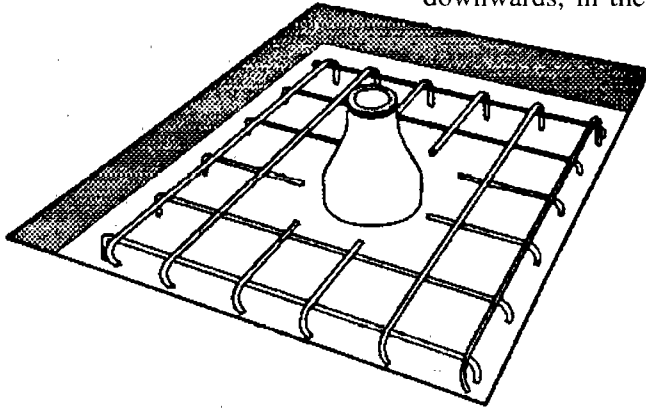
**Figure 12. Reinforcement grid**

- Put the grid in the pit. Bend the ends of the wires, or put a small stone at each corner, so that the grid stands about 20-30 millimetres off the bottom of the pit (see Figure 13).



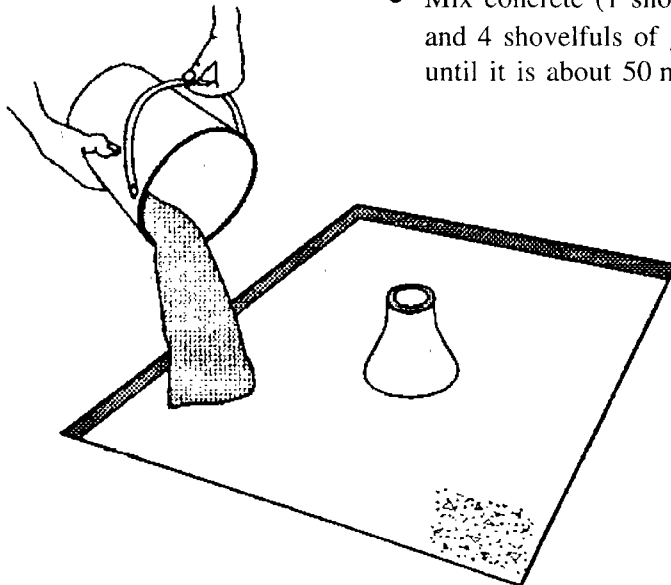
**Figure 13. Grid in the pit**

- Roughen the top 50 millimetres of the outside of a 200 millimetre to 100 millimetre PVC reducer. Place it, wide end downwards, in the hole in the grid (see Figure 14).



**Figure 14. PVC reducer**

- Mix concrete (1 shovelful of cement, 2 shovelfuls of sand and 4 shovelfuls of gravel with water) and pour into the pit until it is about 50 millimetres thick (see Figure 15).



**Figure 15. Laying the concrete**

- Cover the concrete with damp cloths, cement bags, hay or a sheet of plastic and keep it damp. It is important that the cement is kept damp for five days to reach its full strength.
- After five days, attach a 300 millimetre length of 100 millimetre PVC pipe to the small end of the reducer. Fill tank with water.
- Remove the slab and lay it over the pit. Check that the PVC pipe extends 100-150 millimetres below the level of the water. Remove the cover slab and place cement mortar along the top of the tank walls. Then lower the cover slab back into place.
- The surface of a slab produced in this way may be quite rough. It is best to mortar the surface of the slab to make it smooth, and so that it slopes down to the hole.

---

## *The shelter*

The shelter is for privacy and protects the user and the latrine slab from the weather. The shelter can be made from any suitable materials. The shelter is placed on the base of the latrine. The shelter should be high enough for comfort ; the height will depend on the users of the latrine. Openings of 100 to 150 millimetres width should be provided at the top of the shelter walls for constant ventilation. The roof should cover the shelter completely and have a large overhang to protect the mound and the walls from rain or roof drainage.

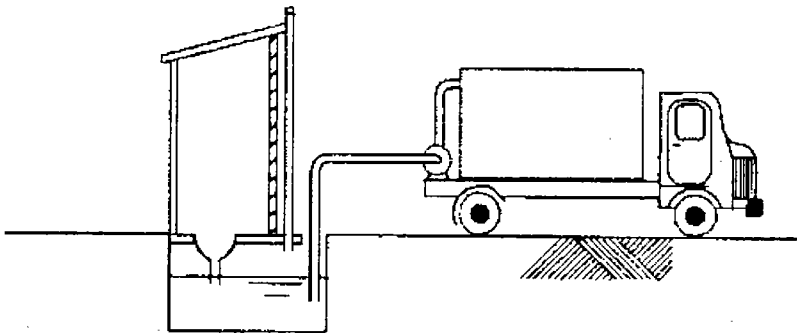
Water should be kept nearby to top up the tank daily. This will usually require one or two buckets (roughly 25 to 50 litres) per day, unless there is a leak. It is also a good idea to keep some water nearby to flush the pan after each use. This need only be a small amount of water to keep the aquaprivy clean.

---

## *Care of the aquaprivy*

An aquaprivy can be pleasant to use and can help to prevent the spread of cholera and other diseases, but only if it is kept clean. Wash the aquaprivy every day with a brush and soapy water. Water that has been used for rinsing clothes is ideal for this.

Aquaprivies fill slowly with sludge from the solid waste entering the tank. Every three years the tank must be emptied of sludge. This is usually done using a tanker with a suction pump, as shown in Figure 16.



---

**Figure 16. Desludging an aquaprivy with a tanker and suction pump**

The life of the soakaway will vary widely, largely according to the type of soil in which it is built. Most pits eventually fail. This can be recognized by the pit filling with water and often by problems of odours. When a soakaway fails it is necessary to build a new one to replace it.

Do not use strong alkalis or disinfectants such as chlorine bleach in an aquaprivy. These will stop or slow down the biological processes in the tank.

During an epidemic, the floor of the aquaprivy should be cleaned daily with disinfectant such as bleach (sodium hypochlorite).

# Septic tanks

---

## *Septic tanks*

Septic tanks are watertight chambers sited below ground level which receive excreta and flushwater from flush toilets and other domestic sullage (collectively known as wastewater). The solids settle out and break down in the tank. The liquid remains in the tank for a short time before overflowing into a sealed soakaway or drainfield where it infiltrates into the ground. A permeable soil is essential for the soakaway to function properly.

Septic tanks must be emptied periodically (for instance, every three years) and the solids disposed of hygienically. This is usually done with a vacuum tanker.

Septic tanks allow safe disposal of wastewater, particularly in rural areas where it might otherwise go directly into rivers. Septic tanks can also be used in urban areas (provided a suitable site for the soakaway is available) but other options such as pour flush latrines, aquaprivies or sewerage may also be selected, based on financial and technical factors. Septic tanks can be later connected to small-bore sewers if so desired. Further information concerning small-bore sewerage and other forms of sewerage are covered in Fact Sheet 3.11.

Septic tanks have the advantages of little maintenance, isolation and partial treatment of excreta, few odour or fly problems, and the possibility of subsequent connection to a sewerage system. Their disadvantages are high cost of construction ; the need for periodic mechanical emptying ; the need for large volumes of flushing water ; and the fact that soakaways can overflow if not designed, built and operated properly. Septic tanks are only suitable where flush toilets are used and there are reasonably large amounts of domestic sullage to be disposed of. They are therefore most likely to be built where there is a house connection to a water supply.

Septic tanks produce liquid effluent which must be disposed of by infiltrating into the ground. The liquid effluent contains large numbers of germs which are dangerous. It is important that they are only disposed of by infiltration, thus septic tanks should only be built where the soil is permeable and the liquid effluent they produce will infiltrate. Where soils are very permeable, however, there is a risk of groundwater contamination from soakaways, particularly where the water table is high.

The permeability of soil can be assessed by measuring the percolation rate, as described in Fact Sheet 3.6. If the percolation rate is 15 mm/h or more, then it is usually considered that the soil has sufficient percolative capacity for a septic tank soakaway or drainfield to be constructed. When the soil has a percolation rate of below 15 mm/h, then excreta disposal options which do not require soakaways or drainfields should be sought. Where results are marginal, local experience may indicate the appropriateness of these technologies.

## *Where to build a septic tank*

The septic tank should be :

- Downhill and the minimum safe distance from any drinking water source. This is site specific and should be established for each water source on the basis of local hydrological and hydrogeological conditions.

A distance of 30 metres has been suggested by some workers as standard practice. It is recommended that this figure is taken as a guide to establishing a minimum safe distance, in the absence of local information.

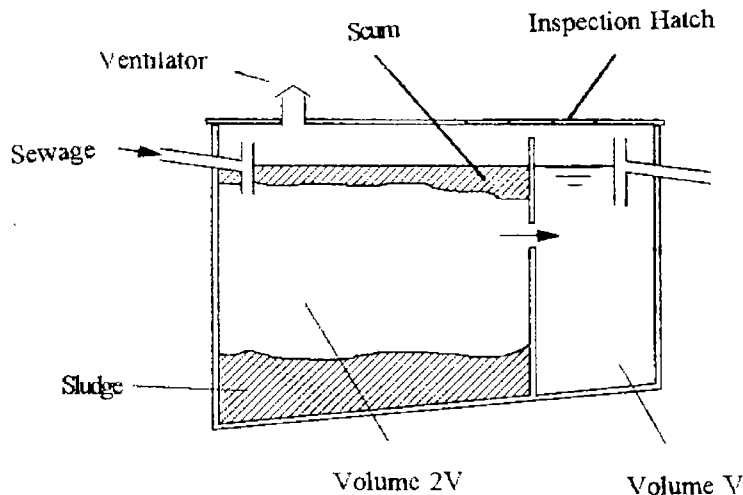
The soakaway should be :

- Downhill and the minimum safe distance from any drinking water source.
- At least 3 metres from the septic tank.

---

## *Building the septic tank*

The septic tank should be designed to hold three times the volume of waste water flowing into it every day. This allows the solid material to settle out. It is best to build a septic tank with two compartments, the first compartment being twice the size of the second (see Figure 1).

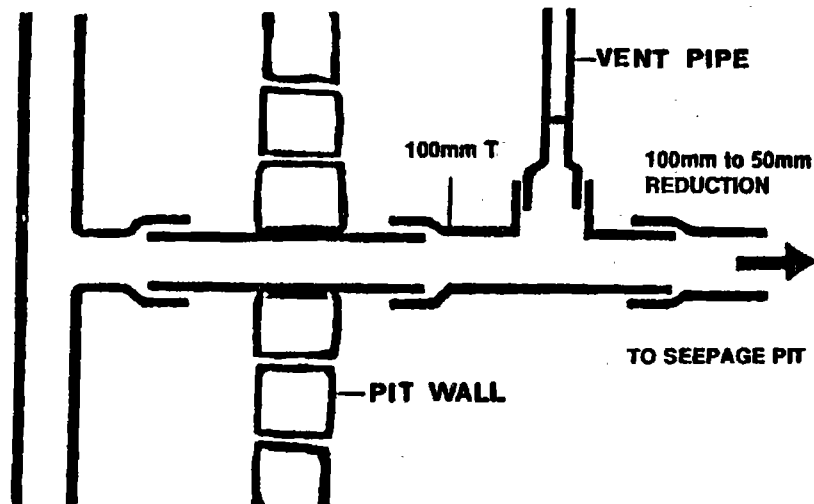


**Figure 1. Two-compartment septic tank**

The volume of the tank should be at least 1.5 cubic metres, with an additional 300 millimetres space above the water level.

Building a septic tank should be undertaken by skilled or semi-skilled individuals. Experience of working with concrete is essential. The general steps to be followed are described below :

- *Estimate the required volume. If it is possible to estimate the volume that will flow into the tank daily, then the tank should hold three times this volume of liquid. A family generally uses from 0.5 cubic metres to 1.5 cubic metres per day.*
- *Design the tank. There should be 300 millimetres of space between the level of the liquid and the roof, to allow for an overflow. There should be a wall dividing the tank into two compartments - the first being twice the volume of the second. The two compartments should be joined by a pipe at the level of the outlet. The inlet, compartment connector and outlet overflow pipes are generally of 100 millimetre diameter PVC pipe.*
- *Build a reinforced concrete floor. Build up the walls, including the dividing wall. Incorporate the inlet, outlet and compartment connector pipes in the walls as they are built. The walls are most commonly made of reinforced concrete, bricks or mass concrete. Mass concrete will be the preferred material, except for small septic tanks.*
- *The tank should be waterproof. Render the inside with cement mortar. Add "T" junction pipes to the inlet, outlet and compartment connector pipes, as shown in Figure 2. These are to protect against scum blocking the pipework or being carried over into the seepage pit.*



**Figure 2. Septic tank pipework**

- Add a reinforced concrete roof with an inspection hole over each compartment of the tank. Make reinforced concrete covers with handles for the inspection holes. The covers should either be of the sanitary type or be cemented into place using a very sandy mortar mix. This is to stop flies and vermin getting into the tank or odours getting out. The mortar can easily be broken to remove the covers.

### *Final disposal of liquid waste*

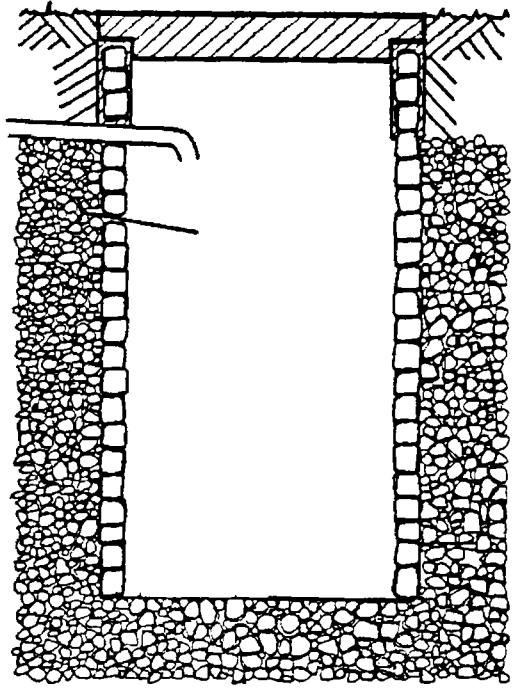
Care must be taken with the liquid part of the wastewater, as it contains many germs which are dangerous to health. The outlet of the septic tank should carry the liquid part of the wastewater to a soakpit or drainfield, where it will soak into the ground and any organic material in the effluent will be broken down by bacteria in the soil. The outlet pipe should be laid with a slight slope (1 in 100).

### *Soakaway*

A typical soakaway for a family septic tank would be about one metre in diameter, or square, and 2.5 metres deep.

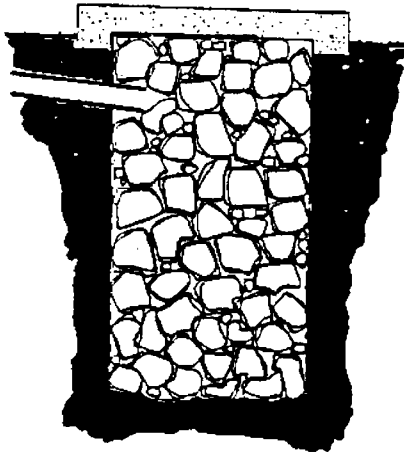
The soakaway can be lined with unmortared brick or stones as shown in Figure 3. A splash plate should be added to prevent cavitation or boring in the soakaway, as well as to distribute the flow.





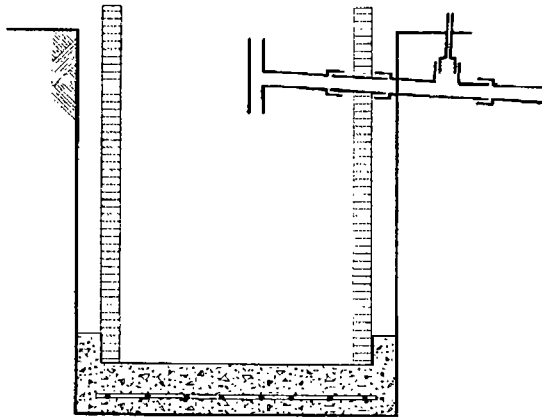
**Figure 3. Lined soakaway**

Alternatively, the seepage pit can be unlined and back-filled with rocks or stone, as shown in Figure 4.



**Figure 4. Unlined, back-filled soakaway**

The soakaway should be covered with a concrete lid, or with well-compacted clay or soil, to stop flies getting into the pit. The outlet pipe from the septic tank must enter the soakaway close to the top (see Figure 5).

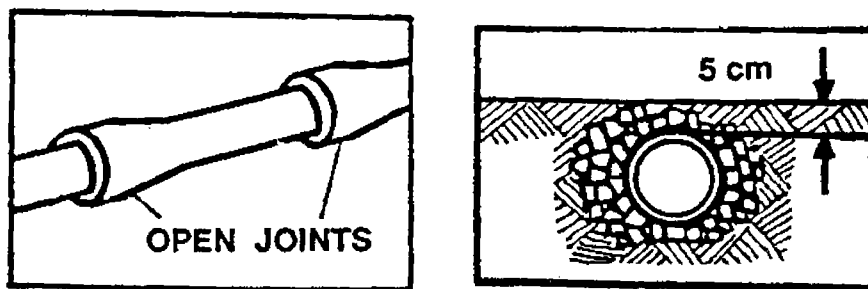


**Figure 5. Outlet from septic tank to soakpit**

## Drainfields

The liquid from a septic tank outlet can also be disposed of using drainfields. These are long lines of ceramic pipes with open joints buried in a trench just below the surface of the ground. The liquid seeps out of the joints and into the ground. Two trenches 450 millimetres wide, 450 millimetres deep and 30 metres long should be dug and then filled to a depth of 300 millimetres with gravel.

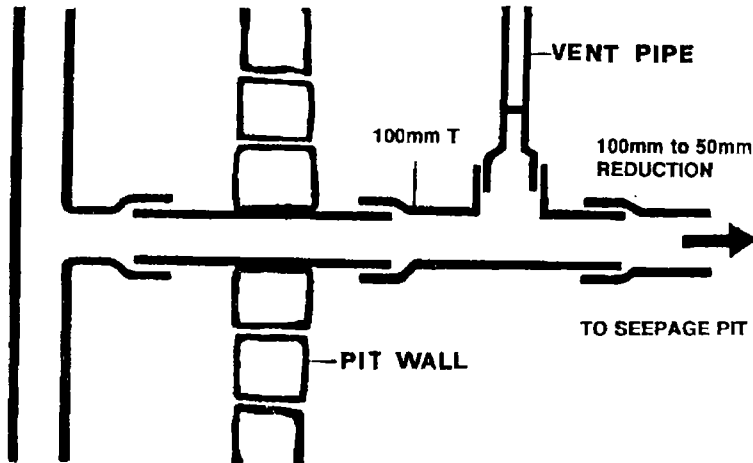
Ceramic sewer pipes, 100 millimetres in diameter, with bell and spigot joints, are the best type for building drainfields. A space of 6 to 12 millimetres should be left between pipes to allow the liquid to seep out. The pipes should be laid at a slight gradient (1 in 500 or 0.2 per cent) to help distribute the liquid to the whole length of the drainfield. After laying, the pipes should be covered with a layer of gravel to a depth of 50 millimetres above the pipes (see Figure 6).



**Figure 6. Drainfields**

## Vent pipe

A vent pipe is required to allow the gas, formed in the septic tank by breakdown of excreta, to escape. The vent pipe can be installed on the sewer pipe running from the house to the septic tank, using a 100 millimetre diameter PVC "T" and a PVC reduction from the 100 millimetre diameter sewer size to 50 millimetres in diameter. The vent pipe layout is shown in Figure 7. The vent pipe should be 50 millimetres in diameter, reach roughly half a metre above the top of the house and have a fly screen covering the end.



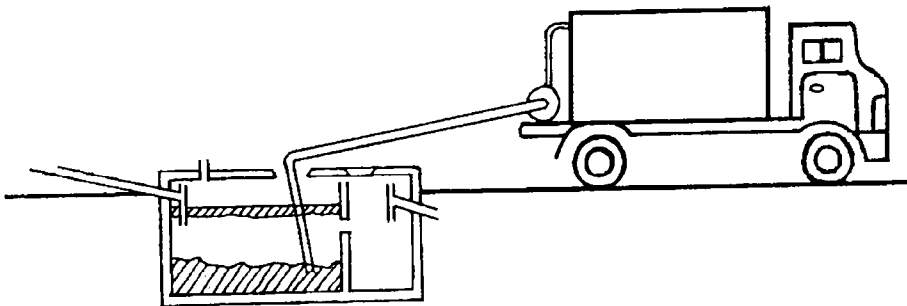
**Figure 7. Vent pipe**

### *Operating the septic tank*

Never use strong alkalis or disinfectants such as chlorine bleach in the septic tank. These chemicals will destroy or slow down the biological processes in the tank.

Before commissioning the septic tank, it should be filled with water up to the outlet level and, if possible, two buckets of sludge from a working septic tank or cow manure should be added to seed the tank with bacteria. This will make the tank more efficient from the start.

The septic tank fills slowly with sludge from the solid waste entering the tank. Every three to five years, the tank must be emptied of sludge. Usually this is done using a tanker with a suction pump, as shown in Figure 8.



**Figure 8. Desludging a septic tank with a tanker and suction pump**

Both soakaways and drainfields can block after a few years of use and the liquid will overflow. To stop this happening, the soakaway or drainfield should be checked every year and a new one built before the liquid starts to overflow and becomes a health hazard.

# Disposal of sullage and drainage

## *Why is it important to dispose of sullage ?*

Sullage is the used water resulting from washing clothes and kitchen utensils, shower or bath water and other domestic water not containing excreta. Sullage can have a lot of germs in it and so is dangerous for children who may play in it or even drink it. The quantity of sullage varies with the quantity of water supplied and certain local practices, such as whether personal and clothes washing is done at the home or at the water source.

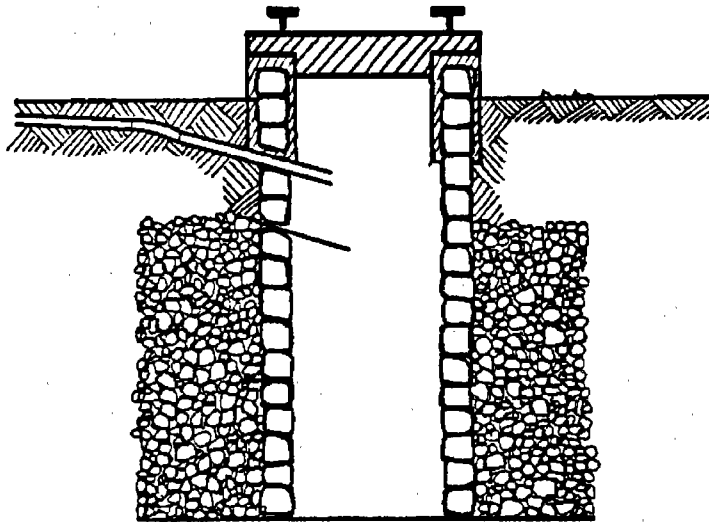
Sullage often collects in pools which then make good breeding places for flies or mosquitoes which may spread yellow fever and dengue fever. Some types of germs, such as cholera, can also grow and multiply in sullage pools and become a major risk to public health. Mixed sullage contains significant amounts of organic material and when this decays it may result in unpleasant smells.

Although sullage is not a primary contributor in the spread of cholera, it can help the spread of other diseases and should be disposed of carefully. Where water-flushed sanitation does not exist, domestic sullage should be disposed of separately from excreta. Any pools or areas where sullage collects should be kept dry by building permanent drainage and filling in any holes with earth or sand.

## *Disposal of sullage*

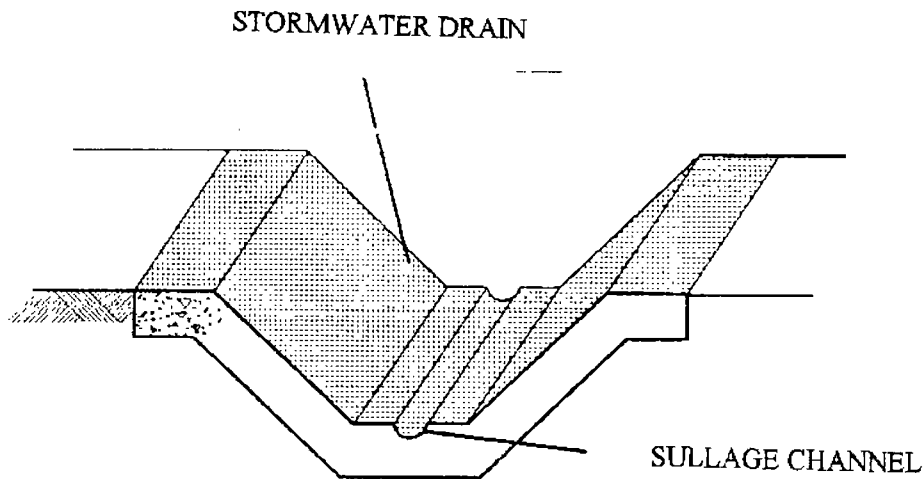
Sullage from the house can be disposed of in several ways :

- It can be used for watering garden crops, provided a suitable sized plot is available and the soil is sufficiently permeable. This method is particularly important in dry areas where sullage may be the only water available for small scale irrigation.
- Allow the sullage to flow into a septic tank if this is already built. Take care to fit water seals on sullage drains to stop any odours from the septic tank passing up the sullage drain and into the house.
- Construct a soakaway pit which allows sullage to soak into the ground (see Figure 1). This type of pit only works in absorbent soils such as sandy soil. Where soil contains a lot of clay, water will not seep into the ground and the pit will quickly fill up and overflow. Add a splash plate to prevent cavitation or boring, as well as to distribute the flow.



**Figure 1. Soakaway pit**

- Where the soil contains a lot of clay, sullage from a single household can be allowed to flow over the soil around crops, which helps to absorb the water. It is important to let the water flow over as large an area as possible by digging irrigation channels to stop the sullage forming in pools. This method does not usually work well in urban areas where many houses are producing sullage in a small area. In the wet season, when the soil is saturated, this method is not recommended.
- In urban areas where many people live close together, it may be best to lay a piped drainage system, such as small bore or conventional sewerage, to remove both sullage and effluent from toilets and septic tanks. Fact Sheet 3.10 describes lagoons and other forms of sewage treatment methods.
- Sullage may be discharged into stormwater drains. Careful hydraulic design is necessary if both sullage and stormwater are to be disposed of in the same drain, to prevent solids in the sullage being deposited in the drain and causing an obstruction to the flow. This can create ponds of sullage which will encourage the breeding of flies and mosquitoes. A minimum gradient of 1 :150 should be used to ensure adequate flow. The best solution is to construct the drain with a small channel on the floor of the drain to carry sullage. This removes sullage more efficiently than a simple large channel (see Figure 2). Open or covered drains may be used ; these should either be concrete lined or open jointed pipes which should be inspected and cleared regularly.



**Figure 2. Storm drain with sullage channel**

## Drainage

Good drainage is important to the health of communities because it prevents the breeding of flies in stagnant pools and it removes flood water. The removal of flood water is particularly important in low-lying urban areas. If there is inadequate drainage, pit latrines and other sanitation facilities can overflow during floods. There is also a risk that flood waters can contaminate drinking water supplies, burst pipelines and cause sewers to backflow or break. These situations present a major health risk, as excreta will be present in surface waters. Cholera epidemics are very common after natural disasters, such as major floods, when water supplies and sanitation services have broken down. Whilst drainage may not prevent all such events occurring, good drainage will reduce their severity and frequency, and is an essential component of disaster prevention infrastructure.

Poor drainage at communal sites, such as standposts and washing areas, can lead to unpleasant and insanitary conditions. If there are areas in a community where sullage or rain water collects regularly, then drains can be dug to make sure that these areas stay dry. Open or closed drains can be used to carry the water to an infiltration site, such as a soakpit or drainfield. Drains should be laid at a minimum gradient of 1 : 150 to ensure that no solids are deposited on the drain floor. A silt trap can be built at the infiltration site to remove any suspended solids. Drains should be inspected regularly and any debris blocking the drain removed.

There are numerous ways of installing a drainage system, from lined open drains to buried open jointed pipe drains. The latter are shown in Figure 3.

---

**Figure 3. Drain using open jointed pipes**

It is important to be sure, when laying drains, that the soil at the soakpit or drainfield is permeable enough to absorb the water. If it is not permeable enough, another site should be found. To assess the permeability and so the suitability of the soil, the following procedure should be followed :

- *Bore at least six holes of 10 centimetres diameter and 50 centimetres deep over the area proposed.*
- *Add about 5 centimetres of gravel to the bottom of each hole (to protect the bottom).*
- *Fill all the holes with water and leave overnight (to allow the soil to become saturated).*
- *Refill the holes with water to about 15 centimetres above the gravel.*
- *Measure the fall in water in centimetres after 30 minutes.*
- *Calculate the percolation rate as follows :*

$$\text{Percolation rate} = \frac{\text{Water level drop X 60 cm/h}}{30}$$

If the percolation rate is 15 mm/h or more, then it is usually considered that the soil has sufficient percolative capacity for a pour flush latrine, seepage pit or drainfield to be constructed. When the soil has a percolation rate of below 15 mm/h, then excreta disposal options which do not require seepage pits or drainfields should be sought.

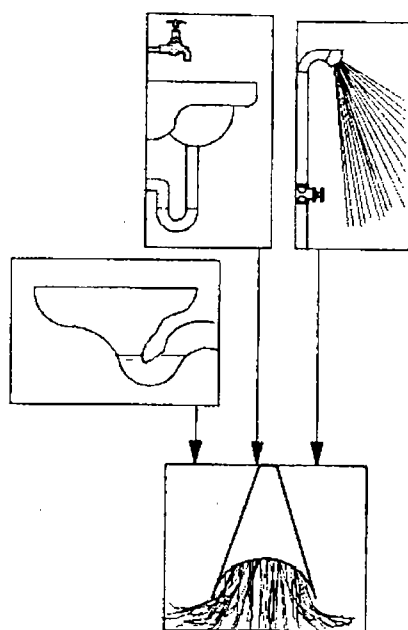
# Sewerage and sewage treatment

Sewerage is the removal of excreta, flushing water from toilets and household sullage through a pipe or sewer network to a treatment works or disposal point, as shown in Figure 1. When this is operated correctly and the waste is treated, sewerage is an effective method of excreta disposal. In many areas of the world, however, sewage is allowed to flow directly into rivers untreated, representing a major public health risk.

Sewerage is a high cost technology and requires water for flushing. It is probably best employed in urban situations or where sufficient finance is available for its proper operation and maintenance. Lower cost sewerage technologies, such as small-bore and shallow sewerage, do however exist. These provide the benefits of water-borne excreta disposal but offer greater potential for community management, as well as having a lower water requirement and thus lower costs.

Sewage should always be treated prior to discharge into any surface water body or disposal onto land. After treatment, sewage can be used for agriculture and aquaculture.

The advantages of sewerage are that it can remove large amounts of wastewater and it provides great user convenience. The main disadvantages are the high capital and operating costs, and the fact that the effluent still contains large numbers of germs. Sewage can be treated in lagoons, and this is generally an appropriate method. The reuse of treated wastewater is covered in Fact Sheet 3.13.



**Figure 1. Disposal of excreta by sewerage**



---

## *Modified sewerage*

There are two types of modified sewerage - shallow sewerage and small-bore sewerage - which work on similar principles to conventional sewerage.

Shallow sewers are laid at shallower depths and gradients than conventional sewers, and are generally of smaller diameter. Unlike conventional sewerage which aims to keep solids in permanent suspension, shallow sewers allow solids to move down the pipe in a series of movements. Each time a blockage occurs, water pools behind the solids until the pressure is sufficient to re-suspend them and move them further down the sewer. Shallow sewers are easier to maintain and cheaper to build than conventional sewers, and the potential for community participation in management is much higher. Sewage from shallow sewers still require treatment, and the cost of this must be considered when installing shallow sewerage.

Small-bore sewers use only short lengths of large diameter sewers to take sewage to an interceptor tank close to the household or main discharge point of a block which collects the solids. Beyond the interceptor tank, only the effluent is carried in small diameter sewers. The interceptor tanks are generally small and require regular emptying, usually by vacuum suction pump. The interceptor tank should *never* be emptied by hand, as it will contain raw excreta and be a significant public health risk. The frequent emptying raises recurrent costs, but as the main sewer is of small diameter and laid at shallow depths and gradient, and the interceptor tanks are small, this greatly reduces the capital costs of sewer installation.

---

## *Conventional sewage treatment*

Sewage can be treated in a conventional sewage treatment plant to remove the solid material in the sewage and also to make the liquid part of the sewage less harmful to humans and fish when it is passed into a river or the sea.

After treatment, the solid part of the sewage (the sewage sludge) can be used as a fertilizer for crops. The liquid part of the sewage (the sewage effluent) can be used for the irrigation of crops.

Conventional sewage treatment employs physical treatment, such as screening, sedimentation, filtration, aeration and drying ; and biological treatment using biofilters (for example, trickling filters and rotating biological contractors), activated sludge, oxidation ponds or lagoons, and aerobic and anaerobic digestion. The sewage sludge is usually treated using anaerobic digesters and thickeners, followed by drying beds.

The main drawback with using conventional sewage treatment is that the sewage effluent may still contain a very large number of pathogenic organisms after it has passed through the treatment plant.

Chlorination of sewage effluent before discharge to inactivate pathogens is not recommended, even if there is a serious epidemic in progress. It is expensive, rarely effective and furthermore may have a severe negative impact on health and environment.

The advantages of a conventional sewage treatment plant are :

- Can treat large amounts of sewage quickly.
- Uses a relatively small area of land.

The disadvantages of conventional sewage treatment include :

- The treatment plant is expensive to build and maintain.
- Sewage effluent may still contain large numbers of pathogens when it leaves the treatment plant.

---

### *Lagoons or oxidation ponds*

Lagoons are often considered as the cheapest and most effective way of treating sewage. The sewage flows into a series of large ponds which allow the solid part of the sewage to settle out and to break down.

The liquid part of the sewage flows into ponds where air and sunlight kill many of the harmful germs in the sewage and make the liquid less dangerous to plants and fish.

A lagoon system has all or some of the following parts :

- Anaerobic pond - a deep pond where most of the solid part of the sewage settles out to the bottom. As oxygen cannot reach down into the pond, the sludge breaks down without it or anaerobically.
- Facultative pond - a shallower but bigger pond which lets the remaining solid part of the sewage settle out, and also allows air and sunlight to kill harmful germs and to make the liquid part of the sewage less dangerous to plants and fish.
- Maturation (final) ponds - usually two or three ponds in a line which allow oxygen and sunlight to kill more harmful germs and to make the liquid safe for passing into a river or for irrigation of crops. Often the maturation ponds are used to breed fish. The more maturation ponds that are used, the cleaner the effluent becomes.

Lagoon systems are usually built in pairs (or in parallel) so that the anaerobic and facultative ponds can be drained down and the sludge dug out every few years. The sludge may be used as a fertilizer or soil conditioner.

The main advantages of lagoons are as follows :

### **Fact Sheet 3.11**

- Can be built and maintained with local materials and labour.
- Do not need expensive or imported equipment such as pumps.
- Can be used to breed fish.
- Sludge can be used as a soil conditioner and effluent can be used for irrigation (see Fact Sheet 3.13).

The disadvantages of lagoons are :

- Need large areas of land
- Need careful but not extensive maintenance, for example grass and plants have to be cut regularly from the edges of the lagoons to stop mosquitoes and snails breeding.

# Solid waste disposal

---

## *Household waste*

Although household refuse does not usually contain such large amounts of germs as excreta, it can cause a risk to public health by attracting flies, mosquitoes and rats, and allowing them to breed. This may encourage the spread of diarrhoeal diseases, as well as diseases like dengue fever, yellow fever, bancroftian filariasis and bubonic plague.

In some countries, used anal cleaning material and children's faeces are thrown away with other household rubbish. This represents a significant risk to public health.

It is better to throw the used paper and other cleaning material into the latrine or flush toilet, than to store it in the house where it is a serious health risk.

When refuse is stored in the home, even for only a few hours, it can attract flies and rats. Refuse must always be stored in a container with a tight fitting lid. The container should be emptied regularly and not allowed to overflow. When the refuse container is emptied, it should be washed with soap and water or cleaned with dry earth or sand.

In cities or large towns, the municipal authorities may provide a refuse collection service which takes household refuse away. In this situation, it is important that all households served have suitable containers for refuse to be stored in whilst awaiting collection. Public cooperation with organized refuse collection will require a considerable effort by community workers. It is important that households served understand fully the conditions of service, particularly when they are asked to use different bins for different wastes.

Where a refuse collection service is not provided, refuse should be divided into four groups which are disposed of separately :

- Vegetable wastes, such as fruit and vegetable peelings and leftovers. These can be composted with straw and grass to give a fertilizer for crops, fed to pigs or put in a biogas digester.
- Tins, glass bottles, and plastic bags and containers. Unless these can be washed and reused, they can cause problems because they do not break down very quickly, and also can hold water where mosquitoes and other insects can breed. These materials should be buried in a pit with a cover.

- Newspapers, magazines and other clean paper (for example letters and used drawing paper). These can usually be recycled or reused for lighting fires, where appropriate. If they must be thrown away, they can be put in the pit with tins, bottles and plastic.
- Batteries, old medicines, used motor oil and other dangerous waste, such as dirty kerosene and fuel. These wastes are dangerous to human health and must not get into groundwater or be dumped in rivers or streams. They must be disposed of in a pit which is covered and well away from any water sources. It is important that children and animals are not allowed near this waste.

---

## *Refuse pits*

Waste which cannot be recycled for other uses should be buried in a pit. Make sure that the pit is well above the groundwater level even in the rainy season, otherwise chemicals or other hazardous waste may contaminate the water supply.

A refuse pit should be located :

- The minimum safe distance from sources of drinking water. This is site specific and should be determined for each water source based on local hydrological and hydrogeological conditions.
- At least 20 metres from the kitchen or food preparation area.
- Not above any drainage pipe which discharges into surface water or a drainfield.
- Well above the highest groundwater level likely in the wet season. Where hazardous waste is being disposed of, the refuse pit should be situated on impervious rock or clay, or the pit should have a sealed base to prevent contamination of groundwater.

Care must be taken to cover all waste put into a refuse pit with a lid or soil. It is important that children are not allowed access to refuse pits, as they will be exposed to a major health risk. Animals should also be kept away from refuse disposal pits, as they may ingest hazardous waste which may be passed on to humans if the animals are eaten.

The life of the pit can be increased by compacting the refuse down using a heavy metal or wooden pole.

---

## *Sanitary landfill*

For large amounts of refuse, the sanitary landfill method is simple, and prevents flies and rats getting to the refuse. The refuse is spread out and compacted to a layer of not more than 0.6 metres thick. At the end of each day, the compacted layer of refuse is covered with 0.3 metres of earth and compacted to stop flies and rats getting at the refuse. Layers of refuse can be added up to a total depth of 2.4 metres and then finally covered with 0.6 metres of earth. A bulldozer or tractor is often used to manage sanitary landfill sites, but the work can be done by hand on small landfill sites.

Landfill sites must never be close to rivers, streams or any other source of water, as materials from the site can contaminate water supplies. Landfill sites should be situated on impervious rock or clay to stop any contamination reaching groundwater. Surface runoff from adjacent areas should be diverted to reduce the amount of water draining through the landfill.

---

## *Incineration*

Where there is a need to dispose of contaminated dry wastes and to kill harmful germs on syringes and needles, used drips, soiled bedding or clothing from health centres or hospitals, an incinerator may be the best option. During outbreaks of contagious diseases it is important that all health centres and hospitals dispose of contaminated dry wastes immediately by incineration. In these situations, contaminated wastes must not be stored or disposed of in pits as they are highly dangerous.

The best type is a commercial incinerator which reaches a high temperature and ensures that all waste is destroyed without producing contaminated smoke. In emergencies and inaccessible regions, a makeshift incinerator can be made using local materials. This should only be used as a temporary measure, however ; a more permanent solution should be sought.

# Reuse of sewage in agriculture and aquaculture

The reuse of wastes in agriculture and aquaculture is a sensitive subject and may be taboo in many cultures. Great care must be taken when introducing these techniques into areas where wastewater and excreta have not traditionally been used, to ensure that crops grown using human wastes as irrigation or fertilizer are acceptable to the consumers.

---

## *Health aspects*

There are some problems with the reuse of sewage for fertilizing and irrigating crops :

- Risk to health from germs in wastewater, which may contaminate the food and spread disease.
- Risk to health, particularly to field workers, from helminths (worms) and nematodes in sewage.
- Risk to health from chemical contaminants in wastewater, generally only in urban areas where factory wastes are discharged into the sewerage system.
- Some chemicals can be taken up by plants. The chemicals stay in the plant and are eaten by humans in the food produced.

---

## *Quality guidelines for the reuse of sewage*

There are set guideline quality standards for effluent and excreta used in agriculture and aquaculture. Effluent which is used to irrigate trees, industrial and fodder crops, fruit trees and pasture should have less than one viable nematode egg per litre. Effluent used for the irrigation of food crops, sports fields and public parks should have less than one viable nematode egg per litre and less than 1000 faecal coliforms per 100 millilitres.

Excreta and excreta-derived products (such as wastewater sludges, composts and latrine contents) which are applied to the field prior to crop planting do not have to meet quality guidelines provided that :

- Wastes are placed in a trench and covered with at least 25 centimetres of soil.

- Farm and sanitation workers are adequately protected during this process.
- Root crops are not planted directly over the trenches.

Where waste products are applied as a topsoil dressing, as in the case of composts, or are applied to the soil after planting, for instance as liquid sludge, the same quality standards should be observed as for effluent used to irrigate food crops. Thus there should be less than one nematode egg per litre or kilogram (wet weight) and less than 1000 faecal coliforms per 100 millilitres or 100 grams (wet weight).

Excreta and wastewater used in aquaculture should have less than 10 000 faecal coliforms per 100 millilitres or 100 grams, and zero trematode eggs per litre or kilogram.

---

### *Recommendations for the reuse of sewage*

Where households use non-sewered sanitation, the reuse of excreta is relatively straightforward. The sullage, *which should not contain any faeces or urine*, but only water used for personal hygiene, clothes washing and domestic cleaning, can be used directly for irrigation of food crops on a small scale. Where on-site systems exist for the safe storage of excreta, for example twin pit latrines (of whatever type) or composting latrines, excreta can be used as a fertilizer. Excreta should be left for at least two years before use in order for the germs and worm eggs to die. Using the excreta too early represents a major health risk to people emptying the pit, to people working in the fields and to consumers.

Where sewered sanitation systems are used, the sewage should not be used for irrigation or fertilization of food crops until it has been passed through a treatment plant, either a conventional sewage treatment plant or a lagoon system. In general, well managed lagoons give better quality final water than conventional sewage treatment. In order to remove helminths adequately, a retention time of 11 days in the lagoons is required. Depending on the temperature, twice as long is required to meet the bacterial guideline. It is important to improve quality control of the effluent water from both conventional and lagoon treatment plants to ensure the highest standard possible for wastewater which is to be used to irrigate food crops and sludge for fertilizer.

Use of disinfectants or other chemical treatments of wastewater to reduce the level of germs is not recommended, even in emergencies, as this type of treatment is expensive, rarely effective and could have a negative impact on the environment.

Where wastewater is used for irrigation or fertilization of food crops, the foods which present the greatest risk to health are fruit and vegetables which grow close to the soil, such as lettuce, strawberries and tomatoes, and which are eaten without peeling or cooking. If fresh fruit and vegetables are stored or in transit for at least 10 days under normal temperatures and humidities, the risk to health is low, but local health requirements should be complied with, for instance washing with chlorinated water before sale.



When irrigating using treated wastewater, the most appropriate method of water application should be used. Subsurface irrigation provides the greatest degree of health protection and efficiency, but is expensive and requires a high level of water treatment to prevent clogging of the emitters through which water is supplied. Bubbler irrigation avoids the need for emitters. Sprinkler irrigation should not be used when the bacteriological quality is not ensured, except on fodder crops and pasture. Under these conditions, flood (border) irrigation should not be used for vegetables. Furrow irrigation often provides the best method of water application, as it is more efficient than flood irrigation, and often sprinkler irrigation, but is less expensive than trickle or subsurface techniques.

Local residents should be fully informed of the location of all fields where human wastes are applied, so that they and their children may avoid them. There is no evidence that local residents are at significant risk from sprinkler irrigation, but sprinklers should not be used within 50-100 metres of houses or roads.

Fish which are bred in ponds using human wastes should be kept in clean water for at least two weeks before harvest to remove objectionable odours and reduce contamination with faecal bacteria. This will not, however, completely remove pathogens from the fish tissues and digestive tract unless contamination is very slight.

---

### *Freshening of products*

In many areas, fruit and vegetables are often soaked in water on the way to market to make them look more attractive. It is common to see this done in a river or stream. This practice is not recommended, as many rivers and streams have wastewaters discharged into them, which may contain faeces and urine. Market areas should, wherever possible, provide clean, disinfected water and facilities for freshening produce brought for sale, in order to discourage the use of local rivers and streams.

---

### *Health education*

When properly treated and applied, the use of wastewater and excreta in agriculture and aquaculture can be of great benefit to the farmer by increasing yields and the area cultivated. There is a health risk, however, to consumers, to people collecting the waste for reuse and to those working in the fields. Where the reuse of waste is practised, an education programme should be established to tell people about the risks and show them how to store and use wastes safely.

In conjunction with an education programme dealing with waste reuse, hygiene education should encourage good food hygiene and preparation in the home. This could greatly decrease the incidence of disease within communities.

# Sanitation in public places

---

## *Long-distance bus and train services*

Toilets should be provided on trains and buses, particularly if they are travelling over long distances. Normally, one toilet for every carriage or bus is enough.

- The toilets must have clean water and soap provided for hand washing, and be cleaned at least once every day with soap or disinfectant.
- Water for use on the journey must be stored in tanks. Chlorination of the water tanks may be practised if water does not meet local quality standards.
- Refuse must be stored on the train or bus until it can be disposed of safely. Bins with well-fitting lids or sacks are the most appropriate containers to stop flies and vermin being attracted to the refuse.

In many countries, toilets on trains allow the excreta to fall directly onto the ground below the train. This is a major hazard to public health, particularly in stations or in areas where people regularly cross or live close to the railway track. The disposal of sullage by this method is less of a risk. Wherever possible on trains and always on buses, excreta should be stored in a tank underneath the carriage, which must be emptied daily into a sewer or septic tank. The tank should be made of plastic or fibreglass or be lined with a waterproof material to stop corrosion in the case of metal tanks.

For workers emptying the tanks, extra safety precautions must be used :

- Pipes should be used to connect the tank to the sewer, to prevent splashing.
- A control valve should be used at the bottom of the tank to drain the tank into the sewer.
- Workers must wear gloves, eye protection and protective clothing when emptying tanks into the sewer.

---

## *Long-distance bus and railway stations*

There are usually large, continually changing groups of people in bus and railway stations. People in stations often have children with them and, because they have travelled for a long distance or are about to do so, they will have need of toilet facilities and running water.

- The station must provide enough toilets to cope with the *maximum* number of people in the station at any one time.
- With the large number of people using toilets in bus and rail stations, there should be at least one permanent member of staff present to clean the toilets and to ensure that there is enough soap, paper (if used) and clean water. Toilet facilities must be cleaned several times every day. A permanent attendant also reduces the chances of vandalism, and prevents the toilet facilities becoming fouled and a health hazard. Toilet facilities can often be made self financing by charging a small sum for their use.
- Water supply is very important and where water supplies are not reliable, water tanks should be built to store water when there is a lower demand, for instance at night. Chlorination of water tanks may be practised if water supplies do not meet local quality standards.
- Refuse collection must be organized, as a build-up of refuse will attract flies and vermin (see Fact Sheet 3.12).

---

## *Ships and ports*

On ships, there should be at least one toilet for every 25 passengers and the following basic rules should be adhered to :

- The toilets must have clean water and soap for handwashing, and be cleaned at least once every day with soap or disinfectant.
- Chlorination of water storage tanks may be practised if water does not meet local quality standards.
- Refuse must be stored on ships until it can be disposed of safely. Bins with well-fitting lids or sacks are the most appropriate containers to stop flies and vermin being attracted to the refuse.

On many ships, the excreta from toilets are allowed to flow straight into the sea, river or lake. Discharge into the open sea may not represent a significant risk to public health, but discharge into a lake, river, port or harbour could cause serious contamination to areas used for water collection, washing, fishing and recreation. Diarrhoeal diseases, such as cholera, could be brought from other areas by passengers on ships and then passed on to local people who swallow water whilst swimming near the ship.

The most practical solution is a storage tank for use when the ship is in port, which can be discharged once the ship is well out at sea. The tank should be made of plastic or fibreglass or be lined with water-resistant material to stop corrosion in the case of metal tanks.

Some large ships have a sewage treatment plant which purifies the sewage and allows the treated liquid to flow into the water. The solids are then pumped out of the ship into the sewerage system in port.

---

## *Cordon sanitaires*

In some countries and ports, a so-called *cordon sanitaire* has been operated or still operates. In these areas, people who are deemed to carry or are likely to carry the cholera virus are refused entry to the area. There is no evidence that this is effective in preventing the spread of cholera. People who carry the cholera virus often show no sign of illness ; such people are called healthy carriers or asymptomatic carriers. There is no practicable way of identifying all healthy carriers and it is not feasible to prevent their movement by restrictive measures. Even if formal traffic across borders is controlled, informal and illegal traffic invariably continues and cholera continues to spread.

Travel restrictions are expensive to maintain and often have adverse economic consequences, as they prevent normal trade and tourism. Travel restrictions, moreover, may encourage the suppression of official information about an outbreak and hamper collaboration on disease control between international agencies and countries.

Infectious diarrhoeal diseases such as cholera can only be reliably prevented by ensuring that all the population have access to safe drinking water and adequate sanitation facilities. This particularly applies to places where there are large numbers of people, where infection can spread rapidly through contaminated food and water.

---

## *Markets*

As food is handled and eaten by large numbers of people at markets, markets can be the centre for the spread of infectious diarrhoeal diseases such as cholera, typhoid and hepatitis A, if sanitation and hygiene is not properly planned.

There are a number of key points which should be adhered to when planning sanitation in markets.

- Toilet facilities in markets should be away from the food storage or display areas. It is normal to provide separate toilet facilities for staff in the market and for customers. Staff toilets must have an extremely high standard of cleanliness, as staff handle large quantities of foods during the working day.
- Handwashing basins with soap and running water should be provided, both in the toilets and near the market stalls. Chlorination of the water supply may be practised if water does not meet quality standards.

- Clean water facilities should be available for the freshening of produce brought for sale. Where these facilities do not exist, river water is commonly used to soak produce to make it look more attractive. This represents a major public health risk, as river water often contains faecal contamination.
- Refuse must be disposed of safely. Bins with well-fitting lids or sacks are the most appropriate containers to stop flies and vermin being attracted. Refuse must be removed regularly, preferably daily, from the market area to avoid build up of the refuse.
- All street-food handlers should be licensed, but prior medical examination (clinical and laboratory) should not be a condition for licensing or for subsequent renewal of license. The handler should provide personal particulars, intended type of business, and location or area of operation.
- Food handlers should be educated, encouraged or supervised to make sure that they stop their business promptly if at any time they suffer from diarrhoea or vomiting or have boils, sores or ulcers on exposed parts of the skin. Resumption of business after recovery may be subject to authorization by the appropriate food control authority.
- Food handlers should wear clean and proper clothing, according to prevailing local standards. Where feasible, food handlers should be encouraged to wear clean overall aprons, preferably white or light in colour.
- Food handlers should wash their hands with soap and water after handling raw foods, before handling cooked foods, after using the toilet, after handling unsanitary objects such as garbage containers, and after contact with toxic substances such as pesticides and disinfectants.
- In the preparation and sale of food, food handlers should refrain from unhygienic and unsightly practices, such as :
  - chewing or smoking tobacco, chewing betel nut or gum ;
  - touching mouth, tongue, nose, eyes, and so on ;
  - spitting, sneezing and coughing on or near food.

---

## *Schools*

Sanitation in schools needs to be sufficient for the number of students and staff members. One toilet cubicle for every 25 students is normally enough. Separate blocks for male and female students should be provided. Separate facilities are also commonly built for male and female staff.

There are a number of key points to be addressed when planning sanitation in schools.

- Handwashing basins with clean water and soap must be provided in each toilet block.
- Chlorination of the water supply may be practised if water does not meet local quality standards.
- Toilet facilities should be cleaned with soap or disinfectant at the end of every day. Cleaning duties can be the responsibility of the students, operating on a rota basis. If this is done, then a member of staff should supervise the students to ensure that the toilets are cleaned properly and the students wash their hands properly when they are finished. Alternatively, a cleaner can be employed if there are sufficient funds.
- Refuse must be disposed of safely. Bins with well-fitting lids or sacks are the most appropriate containers to stop flies and vermin being attracted to refuse. Refuse must be removed regularly and disposed of safely.

Schools can be instrumental in promoting different types of sanitation. Students can be involved in the design and implementation of sanitation construction projects. They can also take part in health education by designing posters and notices to reinforce hygiene education messages. Where it is possible, health education classes should be held regularly for all students to make them aware of the risks of poor sanitation and hygiene, and to teach good hygiene practices.

## Sanitation in hospitals and health centres

Hospitals and health centres have special requirements for sanitation as they may have to deal with patients who are infected with diseases such as cholera, typhoid and hepatitis A. Staff caring for these patients are exposed to a higher risk of infection than the general public, as are other patients who may be weak and unable to fight infection.

There are a number of key points which must be addressed when planning sanitation in hospitals and health centres.

- Toilets for patients with infectious diseases must be separated from toilets for staff and other patients. If possible, staff treating infected patients must not work with other patients who may be vulnerable to infection.
- Toilet facilities should be thoroughly cleaned several times during the day.
- It is very important that excreta and sullage from hospitals and health centres are correctly treated. Hospitals should generally have their own wastewater treatment plant (for further information see Fact Sheets 3.10 and 3.11. This may not be possible for small health centres, in which case it is important to ensure that excreta and sullage are disposed of safely where they cannot contaminate water supplies or areas of human activity, such as fields.
- Facilities for washing and sterilizing bedpans hygienically should also be available.
- Chlorination of water supplies and storage tanks may be practised if water does not meet quality standards.
- Refuse must be disposed of safely. Bins with well-fitting lids or sacks are the most appropriate containers to stop flies and vermin being attracted to refuse. Refuse must be removed regularly, at least daily, and disposed of safely.
- Any contaminated materials such as syringes, needles, drips or bedding should be collected separately from other waste and incinerated on the hospital site, well away from patients, to kill any germs present.

---

## *Disposal of human wastes at hospitals and health centres during cholera outbreaks*

During an outbreak or epidemic of infectious diarrhoeal disease, the treatment of stools and vomit is an important factor in controlling the spread of the disease. There are a number of ways of treating wastes from cholera patients.

- The simplest method for a family or small rural health centres is to put stools in a pit latrine or to bury them.
- In larger health centres and hospitals, the liquid and solid waste from cholera patients can be sterilised or buried. Stools and vomit can be sterilized using a disinfectant such as cresol or lysol. After sterilization, the waste should be buried or put into a toilet or latrine.
- Hospitals can use acid solutions which are mixed with the waste to lower the pH to below 4.5. Generally, after 15 minutes the waste will be safe for disposal in a toilet or latrine. *It is important not to use too much acid to lower the pH more than necessary. The toilet and other installations must be corrosion-resistant, or extensive damage may be done to the sewerage system. Acid should not be used where hospitals sewage is disposed of in septic tanks, as it will damage the function of the tank. The latter also applies to pit and compost latrines.*
- Semi-solid waste should preferably be incinerated, provided that the incinerator is designed for the destruction of wastes. This waste should be kept separate from other waste and put into single-use, moisture-proof bags if possible. The bags should be burnt at the same time as the waste. The waste may be taken to an on-site incinerator by handcart or to an off-site incinerator in a leak-proof container. Which-ever means is used, the equipment used to carry the waste should be cleaned after each use and regularly disinfected. If a handcart is used, it should be used solely for waste disposal.

The planning and emergency measures required to deal with outbreaks of cholera and other epidemic disease are covered in Fact Sheets 1.1 to 1.8.



---

## *Health education*

Hospitals and health centres are important places in which to base health education programmes. This is because people attending hospitals and health centres are generally more receptive, as they are either ill, with someone who is ill or having their children vaccinated. Eye-catching posters should be put up around the reception area and elsewhere to convey health education messages. Health education classes, using techniques such as role playing, can be arranged to coincide with particular clinics. These can target specific groups within the community, in particular women with young children.

A good time for health education is at vaccination clinics. Because groups of women with infants will present for some time at these clinics, a much wider range of health education techniques can be used, taking advantage of the static audience. Thus, in addition to posters with general information, more specific messages can be relayed using role playing, songs and group discussion. Emphasis can be placed on the need for good water, sanitation and hygiene to keep the children healthy.

# The role of hygiene education

---

## *The need for hygiene education*

In many settings, the provision of clean accessible water and ideal sanitation facilities is not within the community's reach. But communities and individuals can still adopt improved hygiene behaviours which can lead to better health. They can also work gradually to improve their sanitation and water facilities. Even when good facilities are available, they will not lead to a great improvement in health unless they are accompanied by changes in hygiene behaviours.

---

## *What hygiene education seeks to do*

A good hygiene education programme provides information and understanding about those behavioural changes which bring the greatest health benefits, and proposes gradual improvements both in practices and hygiene facilities. Hygiene education means helping individuals, families and communities to become aware of the links between poor hygiene behaviours and disease. It also means encouraging and helping people to improve those behaviours which, if changed, will lead to the greatest reduction in disease. At the level of households and communities, hygiene education will help people to find ways of improving their situation by designing and constructing their own improved facilities.

---

## *How hygiene education works*

Hygiene education and communication support should not solely be a device to make the community accept and use what sanitation technology is provided. It should promote *informed* decision-making and *empowerment* of communities to tackle the causes of cholera and other diarrhoeal diseases. This will involve giving the community opportunities to participate in decision-making and in the selection of sanitation technologies that are most appropriate to their needs.

---

## *Use of appropriate technologies*

Hygiene and sanitation technologies should be effective, acceptable and affordable to the local community. No attempt should be made to try to persuade people to carry out actions that conflict with their cultural beliefs. An appropriate sanitation technology should be compatible with the culture of the community, technically feasible using locally available skills and materials, require the minimum of user maintenance and be simple to use.

For example if initial investigations show that the community prefer to squat when using the toilet, then toilet designs with squat holes should be introduced. If seats are preferred, toilets should have seats. If there is a fear that children will fall into a latrine, the hole can be made small enough so that there is no danger of a child falling in.

It is important to emphasize technologies which provide the maximum public health benefit and take into account factors such as the users' ability to pay. The use of low-cost locally-available materials is preferable in many circumstances. If special materials are needed, it is important to make sure that they are available at affordable prices. When a financial contribution by the community is necessary, the level should be determined taking into account the ability of all sectors of the population to pay. Schemes such as credit loans may be considered to make the programme affordable.

---

## *Intersectoral collaboration*

Cholera prevention education programmes should be accompanied by action in complementary areas, such as water supply, housing, women's programmes and primary health care. People cannot be expected to practise good hygiene if they do not have enough water or live in poor housing. Another important resource is time, especially for women where they have a dual role, for instance in agriculture or industry and the home, and are expected to shoulder the considerable burden of improving home hygiene.

Achieving improvements in hygiene is a massive task to be shared between environmental health services, primary health care workers, schools, home economists and other services. Hygiene education is particularly vulnerable to divisions and lack of coordination between services. The community is often exposed to inaccurate and conflicting information from different agencies ; this should be avoided.

---

## *Community participation*

Community participation is not a way of making people do what someone else wants, but a process of partnership and sharing in decision-making. It is a philosophy which should be incorporated at all levels of the programme.

Community participation at the planning stage will eliminate inappropriate designs and anticipation of unrealistic behaviour changes. It will ensure, for instance, that latrines are used and maintained, and will provide a catalyst for the spread of new ideas through ordinary communication channels.

Careful planning is, however, needed to ensure community participation. The needs felt by a community cannot be determined at a single meeting. A process of active dialogue and *listening* is required. Educational methods should emphasize participatory learning methods that are open-ended and promote critical consciousness. Effective participation requires fieldworkers to spend a considerable length of time in a community, building up a relationship of trust and overcoming divisions and conflicts that may exist.

Staff and project donors should be briefed on the full implications of community participation. A programme should incorporate a realistic time-scale, open-ended objectives, an infrastructure of field staff and opportunities for training in communication skills.

---

## *Primary health care*

Cholera control activities should be integrated within a comprehensive primary health care approach. Primary health care emphasizes a decentralized approach to health care using appropriate technologies, community participation and health education. These are undertaken as part of a multisectoral approach which addresses social and economic issues, such as the need to provide food, water and sanitation and also to tackle poverty and inequality.

---

## *Planning cholera prevention programmes*

Planning a cholera prevention programme in a community involves taking the following steps :

- Dialogue with the community and local agencies.
- Selection of priority cholera prevention behaviours for change, based on surveillance data and the needs felt by the community .
- Analysis of influences on selected behaviours and implications for hygiene education.

Preparation of an *action plan* for hygiene education includes making the following decisions :

- How will community participation be achieved ?
- Who should the education be directed at (target group) ?
- What should the content of the education be ?
- Who should carry out the educational activities ?
- What educational methods should be used ?
- What accompanying social and economic programmes are needed ?
- What other fieldworkers or sectors should be involved ?
- How can technologies be designed to make them affordable and acceptable ?
- How will the programme be managed ?

# Focusing on key hygiene behaviours

---

## *Identifying the most important hygiene behaviours*

There are many transmission routes for cholera, all of which are influenced by different hygiene behaviours. A hygiene education programme, however, cannot concentrate on all behaviours immediately. It is important to rank behaviours in terms of their potential impact, and to target those hygiene behaviours which, if altered, will have the greatest effect in reducing the transmission of infectious diarrhoeal disease. In order to identify these behaviours, the community's current practices, the disease pattern and environment must first be studied.

In order to identify priorities, the following questions will need to be asked, among others :

- What is the evidence that the behaviour represents a problem in the community ?
- Which behaviour changes will have the greatest impact on improving health ?
- What are the specific behavioural requirements of the water supply or sanitation facilities that are being promoted in the community ?
- Which hygiene behaviours will be the easiest to change ?
- What do the community consider to be their needs and priorities ?

Based on an understanding of the community, it should be possible to identify the hygiene behaviours to be tackled. The community should have a say in deciding which behaviours should take priority. Hygiene practices which the community already sees a need for and which do not conflict with any traditions should be the focus for initial efforts. Hygiene practices which the community do not see as important or which conflict with their culture and traditions will require more effort to change.

---

## *Behaviours which together prevent the transmission of cholera*

---

### **Water sources**

- All children, women and men in the community should use safe water sources for drinking, washing of clothes and bathing.
- Water should be efficiently used and not wasted. Wastewater should be properly disposed of.
- Improved water sources should be used with care and maintained in a good condition. There should be no risk of contamination of water sources from nearby latrines, wastewater drainage, animals or chemicals.

---

### **Water treatment**

- If necessary, simple treatment procedures should be carried out. This will often mean the chlorination of drinking water supplies.
- If necessary, water should be filtered to remove any solid material before chlorination.

---

### **Water collection**

- Drinking water should be collected in clean vessels, without coming into contact with hands. Water should be transported in a covered container.

---

### **Water storage**

- Water should be stored in vessels which are covered and regularly cleaned.
- Drinking water should be stored in a separate container from other domestic water, wherever possible.

---

### **Drinking water**

- Drinking water should be taken from the storage vessel with a dipper or ladle so that hands, cups or other objects cannot contaminate the water.

---

### **Water use**

- Adequate amounts of water should be available and employed for personal and domestic hygiene. It is estimated that 30-40 litres per person per day are needed for personal and domestic hygiene.

---

### **Food handling**

- Hands should be washed with soap or ash before preparing or eating food.
- Vegetables and fruits should be washed with safe water, and food should be properly covered.
- Kitchen utensils should be washed with clean water as soon as possible after use and stored in a clean place.

---

### **Excreta disposal**

- All members of the community should use sanitary excreta disposal facilities at home, work and school.
- All faeces, especially those of babies, young children and sick people, should be safely disposed of.
- Latrines should be regularly cleaned and maintained.
- Latrines, seepage pits or drainfields from aquaprivies and septic tanks, should all be sited so that the pit contents cannot wash into water sources or enter the groundwater.
- Handwashing facilities, including soap or ash, should be available, and hands should always be washed after defecation, after handling the faeces of babies, before feeding and eating, and before preparing food.

---

### **Sullage disposal**

- Household wastewater should be disposed of or reused properly. Measures should be taken to ensure that wastewater is not left to create breeding places for mosquitoes and other disease transmission vectors or to contaminate water sources.

# Collecting information about current hygiene practices

---

## *Making a community diagnosis*

A community profile or diagnosis is needed to plan hygiene education activities. Planning the survey involves making decisions about :

- Û What information is required.
- Û How that information should be collected to obtain a true picture of the situation and to avoid bias and errors.

---

## *Types of information required for cholera prevention programmes*

---

### **Basic information on the community**

This will include : size and composition of the population, groups at risk, income, educational level, religion, and socioeconomic group.

---

### **Current hygiene practices**

Information gathered at the initial stage of making the community profile gives baseline data against which to set objectives and evaluate the programme.

---

### **Perceived needs of the community**

Health educators will use medical criteria to identify the needs of the community. They must, however, find out what members of the community feel are their priority health needs. These may be expressed needs that have already been put forward by the community or by the voluntary and government workers in the area, or felt needs that have not yet been expressed, and can only be determined when time is spent in discussion of these issues.

---

### **Existing channels of communication within a community**

These may be informal channels, such as neighbourhood social networks, opinion leaders, shopkeepers and tea shops, or formal channels, such as schools, health workers, community workers and youth leaders.

Also important are details of what media are available and popular, for example newspapers, magazines, and radio and television programmes.



Find out what health information is already being conveyed through these existing channels of communication. Does it agree with or contradict the needed health and hygiene messages? Can these communication channels be mobilized?

---

### **Influences on health behaviour**

Influences may operate at the individual, family, community or higher level. They include: the physical conditions of the area, such as housing and environment, and the availability and quality of services such as water supply, clinics and schools; the local norms, beliefs, attitudes, values and knowledge that make up the community culture; and the power structure, both formal through elected politicians and officials, and informal through community leaders, opinion leaders and others.

---

### *Data collection*

- Use more than one method or source of information and then check if the information obtained from the different methods agrees; this is called triangulation.
- Choose people to talk to (the sample) that are representative, in terms of age, sex, education, income and so on, of the group being investigated. Do not just interview people who are easier to contact because, for example, they live nearby or come to clinics. One way of sampling the population is to make a random sample. This can be done, for example, by writing down the names of all the people on separate sheets of paper and picking them out of a box.

Another simple approach is to select every third house (although this may sometimes result in bias).

- Take time to explain why the information is being sought. People are more likely to answer truthfully if they trust the interviewer and believe that he or she is going to use the information to help them. Be honest about how the information will be used and emphasize that any information provided will be confidential. It may be better to ask someone else to do the interviewing if it is likely to provide more truthful answers. For example, a young person can interview another young person; a woman can interview a woman; an older person can interview an older person.
- Find out whether, in the community, there are subjects that are considered taboo and impolite to talk of or ask questions about. If this is the type of information that is needed, careful consideration will have to be given to how to ask these questions. One approach is to emphasize the confidentiality of the information.

- Avoid leading persons to answer in particular ways by the questions asked. Explain that the point of the interview is to find out what they *themselves* think. Wherever possible, ask open questions that allow people to give frank opinions in their own words and say what *they* think is important.
- Involve the local communities themselves in planning the survey and doing the interviewing. This approach is called participatory research. This is a good way to encourage community participation and ensure that the community profile includes data that the local community feel are important.

---

### **Qualitative and quantitative methods**

Quantitative research methods collect specific information and facts that can be expressed as numbers. The numbers can then be treated mathematically to produce overall data for the community, for instance, the number of households with different types of excreta disposal facilities, the number of children, specific knowledge about nutrition, the number of people who hold a particular belief about the spread of cholera.

Quantitative information can be obtained through observation, by looking for specific practices. Quantitative data can also be obtained from questionnaires and interviews that ask closed questions. These are questions that have to be answered in a specific way, with numbers, by saying yes or no or agreeing/disagreeing with statements on a list.

Example of closed question :

Do you agree that cholera is prevented by hand washing ? Yes/no.

Example of open-ended question :

What do you think are the causes of diarrhoea ?

Qualitative research methods ask open-ended questions where the community answer in their own words and are given freedom to expand and give their thoughts on the subject. Interviews and observation are used, as well as focused group discussion.

Qualitative research methods can give rich insights into the local situation and peoples' feelings. It is, however, difficult to summarize the information obtained and to obtain a complete picture of a community. Interpretation of qualitative data depends a great deal on the honesty and skill of the person doing the interviews. It is easy to introduce bias by letting personal feelings and interests influence how the data are interpreted.

Qualitative research is particularly useful for rapid appraisals of the situation. It is also used a great deal in helping to develop appropriate communication messages. It can be of use, for example, to find out the views of young people, test out (or pre-test) media such as posters and radio programmes, and get a feel for the impact of a health education programme. Quantitative data are, however, necessary to get some idea of the size of a problem or to convince policy makers of the need to take action.

In practice, it is best to try to include a combination of qualitative and quantitative methods. One approach is to use qualitative methods to get a feel for the situation and to identify issues to include in follow-up quantitative surveys.

---

## *Sources of data*

***Published sources, records and interviews with field staff.*** Start with existing sources, such as the census, previous surveys, and records and files of agencies operating in the area. It is surprising how much useful information can be obtained from the most unlikely sources, such as government reports, minutes of meetings and newspaper reports. Much of the available information may, however, be of poor quality, irrelevant and out of date. Health data from clinic and hospital records can give a useful picture of the local situation, but only represent cases where people have come for treatment. They will miss out cases where people have been treated at home or taken to private or traditional healers.

Look out for field staff from health and other services who have worked in the community and can give the benefit of their experience. Try to meet them and find out what they feel, and compare this with what the community themselves say.

***Interviews in the community.*** The next stage of data collection is to go to the area and meet the people that live and work there.

A useful approach is to interview members of the community and workers in various government and voluntary organizations - the key informants. This both provides information about the area, and is an opportunity to introduce the researcher and present health education interests. Give careful thought to who can be interviewed to get a balanced and true picture.

***Focused group discussions.*** These are discussions with groups of people in the community carried out in a systematic way to provide information on a topic. Groups of people sharing the same characteristics are brought together. A group discussion is guided by questions asked by the interviewer. These should be open-ended and designed to make people respond and discuss. The involvement of the interviewer should be limited to that of a facilitator. Discussion *between* the group members should be encouraged so that the interviewer can observe the language used and the feelings of the group.

***Observation.*** Another way to get to know a community is observation. This involves casual observations and informal conversations with residents of the area on doorsteps and in public places and shops. It is also possible to have a structured observation, with a check list of points to look out for, so that the observation is carried out in a systematic way.

***Action-research approaches.*** The feelings of the community can be elicited by carrying out some health education and asking for comments and feedback. For example, people can be asked for their opinions about a leaflet, poster or film. The researcher might try setting up an advice stall and monitoring what requests for information come from the community.

---

## *Planning a survey*

Surveys can use any of the data collection methods described above on all, or a sample, of the people in a community. Before doing a full-scale survey of a community, it is better to carry out first a small scale pilot survey, such as interviews and focused group discussions. This will give an idea of what topics and questions to include in the larger survey. In planning the survey, the researcher can follow the steps outlined below.

---

## *Questions to ask in planning community health surveys*

---

### **Stage 1 : Define aims and scope of the study**

- Why is a survey needed ?
- What are the needs and problems to be investigated ?
- How will the information obtained be used ?
- Can the information be obtained in any other way ?

---

### **Stage 2 : Decide upon the information requirements**

- What information is required to deal with the community's needs and problems ?
- What information is needed for proposing a solution or for allocating resources to health and community needs ?
- What do the local fieldworkers feel should be included in the survey ?
- What does the community feel should be included in the survey ?
- If funds are limited, what are the most important questions to ask ?

---

### **Stage 3 : Find out whether the required information is already available**

- Has a survey already been carried out in the community which might contain useful information ?
- Are there any books or published reports which deal with similar issues in other communities, at a regional or national level ?

---

#### **Stage 4 : Assess whether the survey can succeed**

- Will a survey provide the information needed ?
- Are there sufficient resources (money, field staff) and time to carry out the survey ?

---

#### **Stage 5 : Making decisions on data collection, sampling and implementation**

- How will the data be collected - observation, interviews, focused group discussions ?
- If using observation, what will be on the check list ?
- If asking questions, what wording will be used and how will the questions be tested to make sure they are understood and acceptable ?
- How are the communities and people in the sample to be selected ?
- How many are to be included ? How long will each interview/observation visit take ?
- When will the data collection take place - time of day, day of week, season ? How long will the survey take to complete ?
- Who will carry out the interviewing ?
- Can local fieldworkers, volunteers or members of the community be involved ?
- Will they need training ?
- What arrangements are needed to get the interviewers to the field ?
- How is the community going to be involved in the survey ?
- How much time is needed to complete all the fieldwork, including visiting and interviewing ?
- How will the data be analysed and presented ?

---

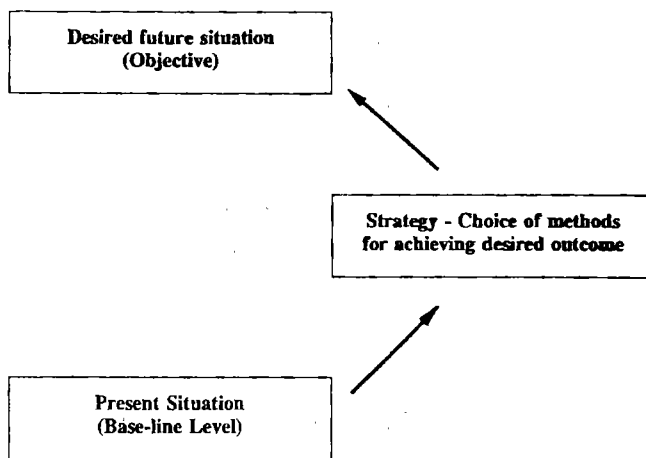
#### **Stage 6 : Estimating the cost of the survey and preparing a budget**

- How much will it cost to undertake the survey, including transport, staffing and other help ?
- Are there non-essential questions that can be left out of the survey to reduce the cost ?
- Could the number of people or geographical area of the sample be reduced ?

# Planning and organization of an education programme

## Planning

When planning a hygiene education programme, the starting point is the present health situation in the community. The planning process is illustrated in Figure 1, below.



**Figure 1. The planning process**

From the information on the current situation, an assessment can be made of the level to which immunization, water supply and sanitation, and so on are required to improve. Then a decision can be taken on what strategy, or method, will be used to reach this level. Finally, the programme should be evaluated to find out whether or not it has reached its target.

In planning the programme, four questions will need to be answered :

- Where are we now ?
- Where do we want to go ?
- How will we get there ?
- How will we know when we get there ?

In other words, planning will have to encompass the present situation, the desired future outcome, the method or strategy by which that outcome is to be achieved, and a way of evaluating the success of the programme.

## *Community participation*

The community should be involved in the decision-making process. This will ensure that programmes are meeting local needs and are seen to be relevant by the community. If the community is involved in decision-making, the programme will be more acceptable and there will be greater participation in programme activities.

---

### *Stages in the community participation process*

There are no fixed rules for developing a community participation programme. Many programmes have, however, followed the steps described below.

***Getting to know the community*** : learning about the community, its structure and leadership pattern ; initial contacts with families, leaders and community groups ; dialogue and discussion on concerns and felt needs.

***Organization building*** : strengthening of community organizations ; establishment of new structures, for instance cholera action committees and women's groups ; educational activities within community structures ; decision-making on priorities ; and selection of community members for training, for instance as water minders or pump caretakers.

***Initial action*** : action in the community on achievable, short-term goals that meet felt needs and bring the community together ; reflection on initial activities ; and setting of priorities for future activities.

***Further actions*** : further activities and expansion of activities, with the community taking a greater share of responsibility for decision-making and management of activities.

The community may already be highly organized and taking action on health issues. It will then only require a few visits by field staff to introduce the concepts of diarrhoeal disease control and involve the community in activities for the prevention of diarrhoeal diseases. The community may, on the contrary, not have a well developed structure ; sections of the community, for example women, may be poorly represented, and there may be disagreements and divisions. In this second situation, setting up community participation will take more time and require many visits. It will be necessary to bring people together, resolve differences, agree on common aims and take action. Even after the community has started activities, further visits will be needed to provide support and encouragement, and to ensure that any new structures which have been created continue to operate.

---

### *Setting objectives and choosing timing*

Setting objectives is an important part of the planning process and is described in detail in Fact Sheet 4.6.

It is important to plan both time and work. This helps in using time efficiently, spreads the workload, anticipates needs, and avoids last minute panic. A simple workplan can be created by writing intended activities on a calendar and circling important days. A year planner can be bought or drawn up. This is a large sheet with a square for each day of the year. Key activities can be entered, using different colours to indicate particular tasks.

One useful approach is to set out programme objectives as a table or a bar chart (sometimes called a Gantt chart), indicating dates for completing planned activities. Another approach is to set out a workplan as a table that shows, for each planned activity, the person responsible for carrying out the activity, the date for completion, and how its achievement and cost will be measured.

When deciding on the timing of the different activities, consideration will need to be given to how long each will take, the availability of staff, and the order in which tasks should be carried out. Consideration will also have to be given to seasonal effects on activities, bearing in mind the wet season, the time when diarrhoea is at its peak, and the periods of the year that people are less busy and can spare time for discussions, meetings and cholera prevention activities.

## *Setting a budget*

It is important to assess needs for money, personnel, facilities, equipment and supplies. The budget should be enough to carry out the proposed tasks. Allowance should be made for increases in prices of goods, and there should be a contingency of at least ten per cent to cover unforeseen costs. Consideration should be given to how funds will be managed, including book-keeping, issuing of petty cash and payment of bills.

## *Effective management*

Effective management requires making decisions on :

- How to *coordinate and support* the activities of the different field staff and organizations taking part and involve them in decisions on future activities ?
- How to *communicate to field staff* new information, skills and changes of policy ?
- How to *monitor progress* and make sure that findings from monitoring and research activities are acted upon as quickly as possible ?
- How to *maintain community participation* throughout the programme ?

Meetings will have to be set up once or twice a year with senior persons in the various agencies participating in the project and the funding body. This formal management group should review progress, and receive reports and financial statements.



It is important to decide who will be responsible for each activity and to describe the nature of any steering group or management committee. A good way of showing this is to draw up an organization diagram or organization chart that shows the different individuals and groups involved, and the lines of responsibility and communication. It is also helpful to describe the role that key persons can play in the programme and to provide job specifications.

A common problem in health education is that fieldworkers give different and conflicting advice to the community, so the community becomes confused as to what they should do. It is important, therefore, that all field staff are briefed to give the correct information.

---

## *Implementation*

At the outset of the programme, it is a good idea to run a training workshop to brief those involved, provide any necessary information and give an opportunity to learn any new communication skills.

It is important to maintain the momentum and enthusiasm of the programme. People are more likely to give support to the programme and put effort into activities if they feel that someone is taking an interest in what they are doing and helping them.

One way to keep in touch is to arrange a regular schedule of visits to different groups. The amount of travelling can, however, be reduced if people are brought together for regular meetings to introduce new ideas, review progress and decide on future actions.

---

## *Monitoring and evaluation*

Suggestions on monitoring and evaluation are given in Fact Sheet 4.13.

# Selecting target groups for hygiene education

---

## *Target groups in cholera prevention programmes*

Cholera prevention programmes involve two kinds of target groups :

**Primary target groups** are the members of the household - children, parents, grandparents, child carers.

**Secondary target groups** are people who should be involved in the programme because of the influence they have in the community, for example local leaders, field staff from other agencies, politicians and traditional healers.

A single hygiene education message will not be enough. It is important to consider the separate needs of each target group in the community, taking into account their educational level, culture, experiences and concerns.

Few people make decisions or perform actions without considering the opinions and views of those around them in their social network. Exactly who has the most influence will depend both on the particular individual and the culture of the community. For example, in some societies the mother-in-law is particularly influential ; in others it may be the elders, including uncles.

The influential people in a community are called opinion leaders. How people respond to issues will depend on whose opinions have the most influence on them. For example, a woman may believe that her friends and the health worker wish her to build a latrine, but her father and husband do not. She is likely to conform to wishes of those most important to her.

---

## *Questions to ask to find out about social pressures :*

- Who are the most influential people in the community ?
- Are there informal leaders who are looked to for decisions, although they remain in the background ?
- What qualities tend to make people's opinion carry weight in the community (money, children, age, education, cattle, wives) ?
- In what areas of life, for example economic, child care, or food production, do the various leaders have influence ?

## Fact Sheet 4.5

- Which leaders within the community are most likely to make decisions that influence community health, the delivery of health care in the area, or various aspects of the health programme ?
- What do they think about the practices which are being promoted ?
- Are there differences of views amongst the different leaders ?
- Could local leaders be involved in the health education programme ?
- What is the best way to communicate with them ?
- How important is family membership in community life ?
- How are families and kinship groups typically organized within the culture ?
- What roles do the father, mother, son, daughter, grandparents (or other persons typically part of the family within a certain culture) commonly play within the family ?
- Where and how does each member typically spend his or her time ?
- How and by whom are family decisions typically made ?
- Who is consulted ?
- What is the typical timing for various types of decisions ?
- Where does the power within the family appear to lie ?
- How do they feel about outsiders ?
- Who generally makes various health-related decisions within the family - what do the family do when a member is sick, who decides whether to take certain preventive measures, what the family will eat, what money can be allotted for health-related expenses, whether a sick member may follow certain medical advice ?
- Do children ever make health-related decisions ? Are they taken seriously if their views differ from their parents ?

---

## *Target groups for diarrhoea education programmes*

---

### **Health services**

Doctors and nurses in primary health care  
Midwives  
Health visitors  
Public health nurses  
Medical assistants  
Nutrition workers  
Home economists  
Village health workers

---

### **Informal processes in the community**

Elders  
Parents and child-rearing adults  
Traditional birth attendants  
Traditional healers  
Village leaders  
Religious leaders

---

### **Public health services**

Public health inspectors  
Water supply technicians  
Sanitation engineers  
Hygiene inspection field staff  
Refuse collection officers

---

### **Education services**

Teachers in primary and secondary schools  
Adult educators  
Literacy teachers  
Pre-school organisers  
Vocational trainers

---

### **Agriculture and socioeconomic development**

Agricultural extension workers  
Community development officers  
Nutrition workers  
Cooperative organizers  
Women's programme workers

# Setting objectives for hygiene education

---

## *Aims and objectives*

An aim is a general statement of what is to be done. An objective is a more precise statement of what is planned over a fixed time period. An objective should be *measurable*. The most important part of planning a programme is setting the objectives. Setting measurable objectives will help to :

- Let others know exactly what is being planned ;
- Make decisions about implementation ;
- Evaluate the programme.

Another word for objective is *target*.

---

## *Intermediate and outcome objectives*

Objectives can be set for the intended *outcomes* of the programme. It is also useful to set objectives for *intermediate stages* on the way to reaching the desired outcome. These are sometimes called operational - or intermediate - objectives. This Fact Sheet shows how these intermediate objectives can be displayed on a workplan and bar chart, and used to monitor a programme.

---

### **Outcome objectives :**

- Improvements in health, for example diarrhoea incidence ;
- Changes in behaviour, for instance handwashing ;
- Changes in knowledge, beliefs and attitudes.

---

### **Intermediate objectives :**

- Initial surveys ;
- Formation of an organizing committee ;
- Training of key workers ;
- Field visits ;

- Broadcasting of radio programmes ;
- Testing of educational materials ;
- Printing of publications ;
- Purchase of equipment ;
- Completion of health education activities ;
- Evaluation surveys.

---

**The objective of using a specific communication or message should specify :**

- The intended change in a detailed measurable form, for instance : acquire facts ; develop decision-making ability ; change beliefs ; change behaviour ; learn a practical skill ; and completion of the training programme.
- The amount of change above the initial baseline level, for instance : the percentage of people able to demonstrate to the interviewer how to make up oral rehydration solution correctly should increase from 10 to 50 per cent.
- Who the communication should be directed at (including where they live). This is often called the target group, for instance : grand-mothers in Eastern Province, adult men in Lusaka, church ministers in the whole country, teachers in Chingleput District, women with one child in Yunan Province.
- The time scale over which the desired change should take place, for instance : over the next twelve months.
- Changes that are relevant and realistic.

---

**Examples of objectives :**

The percentage of children between 3 and 15 years in Bangara District using latrines, as determined by household survey, will increase from the current level of 20 per cent to a level of 70 per cent over the three years between 1994 to 1997.

The percentage of women aged 18-45 years in the six project villages in Tilar District who, on being asked ways to prevent cholera, will include handwashing as one of their responses, will increase from the current level of 10 per cent in 1994 to a level of 80 per cent by 1997.

---

*Workplans*

It is important to set out the general aims of a cholera prevention programme in a table specifying aims, target group, method and accompanying materials. The table can be made into an even more useful planning tool by expressing the aims as measurable objectives and giving dates for the reaching of targets.

# Developing hygiene education messages

---

## *Composition of messages*

Fact Sheet 4.1 discusses the question of how to decide which behaviours should be changed in order to prevent cholera outbreaks in a community. Once that decision has been made consideration will have to be given to what to include in the message in order to influence that practice.

A message is made up of the following parts :

- The *advice* being provided ;
- The *beliefs, values and other factors* to be influenced in order to promote the behaviour ;
- The *language and pictures* that will be used to carry the message ;
- The *appeals* that will be used to persuade people to act.

---

## *Advice*

The advice should be kept to the minimum necessary and should be made as easy to carry out as possible. The enabling factors, such as money, materials and time to carry out the behaviour, should already be available. There may be a tendency to try to ask the community to do more than is really necessary. A good example is the frequently delivered and usually ignored call to boil drinking water. Boiling water takes time, uses scarce fuel and is only relevant when the drinking water is contaminated. Other household water treatment may therefore be preferred because of local conditions.

Advice given in messages should have the following characteristics :

- Result in improved health ;
- Affordable ;
- Require a minimum of effort/time to put into practice ;
- Realistic ;
- Culturally acceptable ;
- Meet a felt need ;
- Easy to understand.

## *Beliefs and values*

The messages in diarrhoea prevention programmes should be based on an understanding of the factors that influence the behaviour of the community in general and the influential persons. These include the beliefs and attitudes that the community hold about the hygiene behaviours - especially perceived benefits and disadvantages of taking action and their understanding of health, disease and hygiene (see Fact Sheet 4.3).

---

## *Language and pictures*

The words used in messages should be simple to understand and familiar to the audience. It is a good idea to use the everyday terms that the community use for the subject themselves. Keep technical words and jargon to a minimum, and try to avoid a literary style. Keep sentences short.

Pictures add interest to leaflets and posters, and can help to explain difficult points and show what things look like. But take the following precautions :

- Make sure that the pictures are accurate ;
- Keep drawings simple - but include enough detail to ensure that they can be recognized ;
- Avoid distracting backgrounds ;
- If colours are used, make them accurate ;
- Symbols may not always be understood ;
- Show things their real size ; be careful with enlargements ;
- Always *pre-test* pictures to make sure that they are understood and arouse interest.

---

## *Appeals*

The appeal is the way the contents of a message are organized to convince or persuade someone.

Many health educators make the mistake of relying too much on medical facts. People, especially those without much education, are often more convinced by a simple emotional appeal. Humour can sometimes help to add interest to the subject. It is a common temptation to try to frighten people into action with symbols such as death, skulls and other fear-arousing images. However, this can run the risk of leading to panic and anxiety, and should be avoided. Avoid negative advice that tells people not to do things. It is always best to be positive and tell people what they can do.



It is also better to be honest and give both advantages and disadvantages of taking action. Leaving out any drawbacks can make people suspicious and think that an attempt is being made to hide something.

---

### *Pre-testing the message*

No matter how well a community is understood, there may be parts of the message that are misunderstood or interpreted differently from the original intention. Always *pre-test* the message with a group of people of similar age, educational level and culture to those the message is trying to reach. This will involve showing them the leaflet or poster, or letting them hear the radio broadcast. They should then be asked :

- Did you understand the message (could you say it aloud correctly) ?
- Was it interesting enough to hold your attention ?
- Did it tell you what you wanted to know ?
- Was the advice acceptable, realistic and believable ?
- Was there any further information that you wanted ?

## Selecting appropriate communication methods for hygiene education

---

### *Communication*

Communication involves sharing information between people and reaching a common understanding. Good communication is a *two-way process*. Planning effective communication involves deciding :

- *Who* is the audience or target group ;
- *Who* should do the communication ;
- *What* should be communicated ; that is, what the message will be ;
- *How* will it be communicated ; that is, what methods will be used.

*Target groups and messages* are discussed in Fact Sheets 4.5 and 4.7.

---

### *Methods of communication*

The choice of communication method and supporting learning aids will depend on what is to be achieved, the nature of the audience and what resources are available. The starting point for choosing methods should be an analysis of what is to be conveyed. Is it necessary to change a belief - and will it be a weakly-held one or a strongly-held one rooted in culture or experience ? Is the purpose to give simple facts, explain complicated ideas or teach a skill ?

Each method has its advantages. For example, to show someone what an improved latrine *looks* like it will require a method that has a visual dimension.

Mass media are the best methods for rapid spread of simple information and facts to a large population at low cost. If the advice is realistic and the message pre-tested, the message can be

accurately transmitted without the distortions that can sometimes take place when relying on word-of-mouth.

In addition, consideration will have to be given to practical considerations such as cost, the need for maintenance, electricity black-out and the ease of use. In a remote area, there may not be access to mass media, such as radio or newspapers. In a city and without a large team, there may be little choice but to use methods such as radio, leaflets or posters that do not need field staff.

A useful guide to planning hygiene education is to start with simpler methods first, such as radio, leaflets, posters and public meetings, and see if they are effective. Only if the simple methods do not work, should there be recourse to the more expensive methods involving extensive use of fieldworkers. Short-term approaches can be accompanied by longer-term strategies, such as working through schools and the workplace (see Fact Sheets 4.10 and 4.12).

---

## *Participatory learning*

In carrying out your hygiene education, emphasis should be placed on *participatory learning methods* which can include small group teaching, simulations, case studies, group exercises and role play. When using participatory learning methods, it is important to remember the following points :

- Avoid formal lecture presentations ;
- Encourage discussion between participants ;
- Encourage active movement and talking during the sessions ;
- Use a variety of games, puzzles and exercises ;
- Use learning aids that stimulate discussion and comments.

Participatory learning methods have many advantages : the participants are active so they are more likely to remember what was introduced during the session ; the participants draw from their own experience ; they are allowed to discover principles for themselves ; opportunities are provided for learning problem-solving skills and empowerment of communities - building confidence to tackle problems and improve their conditions.

---

## *Popular media*

Traditional media, such as drama, songs and story-telling, offer rich potential and have been used for sanitation and hygiene education. They can combine entertainment with practical advice, and can be used to stimulate discussion and community participation. They can be performed by a hygiene or health worker but it is usually better to provide basic information on hygiene and health to the actors and musicians, and let them develop a performance that is entertaining and understood by the community. Another approach is to involve members of the community in performances (see Fact Sheet 4.11).

---

## *Demonstrations*

One of the most powerful forms of communication is through demonstration with real-life examples, such as a demonstration latrine in a well-chosen location and examples of model practice. Demonstrations are most powerful if you can show observable benefits in the short term. Unfortunately the health benefits from sanitation and hygiene can take time to materialize, so it is best to emphasize immediate benefits such as convenience, comfort and, where appropriate, freedom from flies and smells.

---

## *Satisfied acceptors*

Another valuable method is the use of satisfied acceptors. These are persons who have improved their sanitation or practised hygiene measures and are pleased with the results. They are the best people to explain the benefits to the others. They will use everyday language and will have more credibility with the community.

---

## *Communication support materials*

A range of learning materials, such as flipcharts, leaflets, posters and models, can be developed to support education work. These should be pre-tested on a sample of the intended audience to ensure that the pictures and words are easily understood, and that the advice is relevant and meets the community's needs. A useful approach is to use local artists and to encourage them to work with the community to prepare materials (see Fact Sheet 4.11).

---

## *Training of field staff*

It is best to use educational methods that are already familiar to field staff and the community. There will, however, probably be a need to build in some training for field staff and volunteers in communication techniques, especially when using some of the newer participatory learning methods.

---

## *Effective hygiene education*

The characteristics of effective hygiene education may be summarized as follows:

- Promotes actions that are realistic and feasible within the constraints faced by the community.
- Builds on ideas, concepts and practices that people already have.
- Is repeated and reinforced over time using different methods.
- Is adaptable, and uses existing channels of communication - for example songs, drama and story telling.
- Is entertaining and attracts the community's attention.
- Uses clear simple language with local expressions and emphasizes short-term benefits of action.
- Provides opportunities for dialogue and discussion to allow learner participation, and feedback on understanding and implementation.
- Uses demonstrations to show the benefits of adopting practices.

## **Teaching and learning methods for hygiene education**

---

### *Teaching and learning*

- People will learn more easily if the information presented to them is linked to their experiences and builds on what they already know. Always ask questions at the beginning to find out what people know, think and feel about the topic.
- The audience will only pay attention if the content of the teaching is relevant to what they want to know about, is put across in an interesting way and uses a variety of teaching styles.
- Complicated information should be introduced step by step, in a logical organized way. Learning can be helped by well-chosen visual aids. Essential information can be presented in a handout, and the time saved used for discussion.
- Take care not to overload the students with too many new ideas in one session, as there is a limit to the amount of information that can be absorbed at one sitting. Use a range of teaching approaches, such as talks, discussion, exercises and active learning methods. Build in frequent breaks between sessions where people can relax and stretch their legs. Twenty minutes at a time is probably the most people can keep up their concentration.
- Information presented in a teaching session is quickly forgotten. Some further input, either by the student's own reading or reminders by the teacher, is needed for the information to be retained in long-term memory.
- The audience may have enjoyed themselves and express appreciation, but may not have learned anything. The only way to find out whether learning has taken place is by obtaining some feedback - either by asking questions or observing students' performance to see if they have changed.
- Opportunities should be provided for students to practice their newly-acquired skills in a safe, friendly and tolerant environment where they can make mistakes and receive helpful criticism without feeling threatened.

- People learn better if they are allowed to discover principles for themselves and if activities are built into the learning process.

*More active methods* include : practice in real situations with supervision ; practice in class situation, for example role play ; and discussion.

*Less active methods* include : observing a drama or demonstration ; looking at pictures ; studying examples ; paper and pencil exercises ; individual reading.

---

## *Principles of good teaching*

- *Active learning* - make students think and apply the knowledge through a task.
- *Be clear* - use visual aids, speak clearly, use simple language.
- *Make it meaningful* - explain in advance what you are going to teach, explain all new words and ideas, relate what you teach to students' lives and work, give examples, summarize the main points at the end.
- *Encourage participation* - stimulate discussion and involve the group in the learning.
- *Ensure mastery* - check understanding and competence reached.
- *Give feedback* - tell the learners how far they have progressed.

---

## *Participatory learning*

A serious criticism of many health education programmes is that they rely too much on traditional, formal teaching methods where the audience is passive and simply listens. More emphasis is now placed on participatory learning methods and dialogue, such as small group teaching, simulations, case studies, group exercises and role play.

Participatory learning methods have many advantages. The participants are active so they are more likely to remember what was introduced during the session. They draw from their experience. They are allowed to discover principles for themselves and can develop problem-solving skills. Participatory learning methods are especially relevant for those who did not do well at school. Other advantages of using a participatory approach are :

- It makes people think for themselves and less dependent on the teacher ;

- It gives people greater pride in what they can do for themselves ;
- The teacher can discover the beliefs and practices of people in the community ;
- It creates a close feeling between the teacher and the group ;
- It shows the teacher's interest and respect for the opinions of the community ;
- It also makes health education more enjoyable.

---

### *Learning aids*

Well chosen learning aids can help hygiene education activities in many ways. They can be used to :

- Keep the group's interest, arouse curiosity and hold attention ;
- Emphasize key points - when key headings are written out ;
- Allow step by step explanation and sequencing of information ;
- Show how something appears rather than just telling people - for example, what a dehydrated person looks like, the structure of a latrine, transmission routes for diarrhoea ;
- Provide a shared experience for discussion and questions.

---

### **An appropriate learning aid should be :**

- Relevant to the learning objectives ;
- Affordable ;
- Easy to make and use ;
- Well understood by the audience ;
- Interesting and entertaining ;
- Encouraging to participation and discussion.

# Using the mass media for hygiene education

---

## *Mass media*

Face-to-face education in the community can be supported by mass media such as radio, television and newspapers if initial surveys show that they are watched, listened to or read by the community. Carefully designed and tested mass media, such as radio, can be used for rapidly spreading simple information to large numbers of people, increasing awareness and interest in improved hygiene.

Mass media include broadcast media (radio and television) as well as print media (newspapers, books, leaflets and wall posters). Television involves both sound and visual dimensions. Radio involves sound only. Radio ownership is high, even in countries where television is uncommon, which makes it a particularly valuable medium where literacy is low. Print media, such as newspapers, books and leaflets, use the written word and require familiarity in understanding pictures, thus they are only appropriate for audiences who can read.

---

## *Formats on radio and television*

There are many different formats which can be used in radio and television, including dramas, quizzes, songs and interviews with members of the community.

**News.** On most radio and television stations, news bulletins are an important part of the daily output. If it is a local radio station, local news will also be included. To have a health education activity mentioned in a news bulletin is highly desirable because it gives it widespread coverage, credibility, importance and does not cost anything.

**Spot announcements.** These can be public service announcements, such as clinic opening times, immunization sessions and emergency announcements. They will usually be broadcast free. On commercial stations it is also possible to buy time in the form of commercials. This could be useful for a campaign.

**Slogans and jingles.** Slogans are catchy short sentences, designed to attract attention, usually based on well known sayings or rhymes. They can help to identify a campaign. Jingles are slogans set to music. They can make a slogan more memorable and be used to identify a programme, person, radio station or theme.



**Discussions.** There are many kinds of discussion programmes. The one most commonly used on radio is the group or round table discussion. A group of people of different opinions, and possibly from different backgrounds, discuss a common subject under the guidance of a chairperson.

**Phone-in programme.** A programme in which listeners ring in to the studio, either “live” or “off the air”, and give their views, ask questions or ask for advice. Their calls are dealt with either by the broadcaster alone, by an expert in the studio or by a panel involved in a discussion.

**Interview.** A discussion in question and answer form between the broadcaster and one (or two) guests. The interview can also be used to find out opinions of ordinary people either in a studio situation or outside in the community (when it is then called “vox pop”).

**Talks and documentaries.** A 5 to 15 minute talk by one person is occasionally used, but unless the broadcaster is very skilled, it can be boring. Documentaries explore a single topic and include different effects, for example, drama, music, interview, story telling, descriptions and sound effects.

**Drama.** This includes long or short plays, “soap opera”, comedy sketches, serials and drama documentaries. “Soap opera” is the name for a weekly or even daily drama series using the same characters. Drama has enormous potential for health education because the audience can identify with the characters and their problems. “Soap operas” are even more powerful because the characters can become like family friends.

**Music.** Music is an essential part of broadcasting whether it is traditional music, or popular local music, musical jingles or background music to programmes. Music will attract people to watch and listen, and “spot” announcements, public service messages and slogans can be inserted in music programmes. Jingles or songs with a message can become very popular, and people will sing them and remember the message.

**Quizzes and panel games.** Quizzes with panels of guests are popular, and most people watching or listening try to answer the questions themselves and learn something from the answers. One useful method is to ask questions and invite listeners to write in with the correct answer for a prize. This gives feedback on how many people heard the programme and understood the message.

**Magazine programme.** This popular format combines different short elements: music, drama, stories, sketches, interviews, comedy and discussion. They are linked by a presenter and are sometimes aimed at a particular audience, such as women, farmers or young people.

---

## *Audiocassettes*

As mass media are aimed at a large audience, it is difficult to make the message specific to local communities. A useful approach is to prepare radio programmes on cassettes that can be played to small groups or through loudspeakers in public places.

---

## *Getting the press to cover activities*

It is worthwhile trying to encourage newspapers, radio and television to take up diarrhoea prevention in their general news and programme content. To receive media coverage two conditions will have to be fulfilled : the activity has to be something that the media will see as newsworthy ; and the media have to be told what is happening.

Look out for activities in the diarrhoea prevention programme which might be of interest to the media. It is even possible deliberately to include media events in the programme to attract the press. Media events should be fun, lively and of general interest. Some examples of what can be done are : a ceremony with invited guests to launch a new campaign ; a celebration with invited guests to mark an anniversary - for instance the first year free of cholera or the hundredth latrine to be completed ; an exhibition with an official opening ceremony ; and a presentation of prizes for a competition.

Look for ways of making activities visually interesting so that newspapers will want to include a photograph. People can be dressed in costumes ; there can be a procession carrying a coffin bearing the number of children who have died of the disease ; or a latrine or toilet can be carried on the back of a truck through the town.

As part of the media event, there could be a press conference. This is a meeting where journalists can ask questions and find out information. It is always a good idea to put important information on a sheet of paper, as reporters can easily make mistakes in reporting technical information.

The best way to let the media know what is being done is by preparing a press release. This is a written document of not more than one page in length, neatly typed, with an attention-getting headline. It should provide information on what is being done by answering these questions :

- *What* will be happening ? Describe the event. Give names of important people participating and details of activities which might make a good photograph.
- *Why* will it take place ? Give background details and explain why the activity is taking place. Supply some facts and figures that they can quote in a story - for example how many children died of cholera last year in that community.

- *Where* will it take place ? Give precise details of how to get there.
- *When* will it take place ? Give the date and time of day.

Besides background information on the topic, the press release should also give an address and telephone number of someone to contact if they need further information.

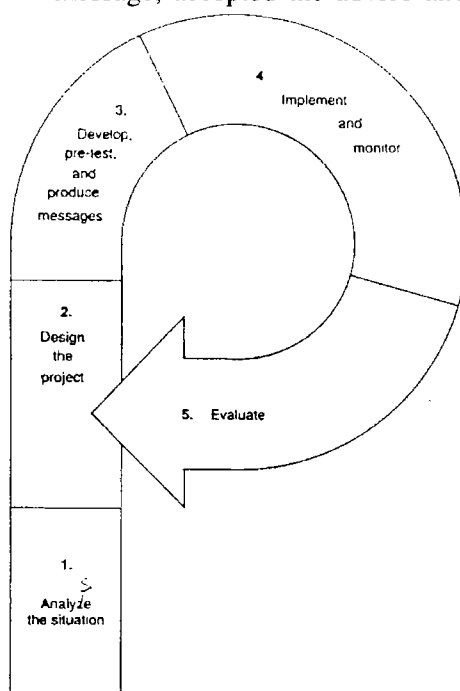
---

### *General guidelines on mass media*

- Decide at the outset what can be realistically achieved by each medium and what cannot. Aim for what can be achieved. Set specific, measurable objectives.
- Base the programme on an analysis of the health issue and its causes. Make sure that the advice given is accurate, relevant and feasible.
- Decide which sections of the public to try to reach and find out what media they watch, listen to and read. Carry out a simple study on what they believe, feel and know about the health issue. Use this information to make the message specific to the particular audience's needs and to decide on the timing, location and content of activities.
- Make friends with journalists and media producers. If they can be provided with interesting stories, they will report the activities and provide free publicity.
- Make the programmes entertaining and avoid preaching. Include popular media such as songs, drama and puppets (see Fact Sheet 4.11). If dramas and stories are used, build up the characters and human interest first before including health messages. Wherever possible, involve people with experience in media in producing programmes. Use sources that are trusted by the community.
- Do not put too many messages into each programme. Always pre-test the programmes and messages with a sample of the target audience before they are broadcast to make sure they are properly understood and accepted.
- Broadcast programmes as often as possible. Make them available in other formats - distribute the radio programme on audio-cassettes, the TV programme on video, the newspaper article as a leaflet.
- Try to identify person-to-person advice systems in the community that could be mobilized to reinforce the media activities. Hold discussions with them before the campaign and, if necessary, arrange for some training. Provide written materials to accompany the broadcasts, such as a

leaflet.

- When using radio or television, prepare reinforcing media such as listening guides, workbooks or simple booklets. A multi-media approach will usually do better than a single channel.
- Always include a way by which the audience can obtain help or further information - either an address to write to or a telephone number.
- Try to build in some mechanism for audience feedback, such as letters, and include some method of evaluation. In the short term, try to find out how many watched, heard or read about the programmes and understood the messages. In the longer term, find out if people remembered the message, accepted the advice and if any change in behav-



our took place.

---

## Planning media production using the “ P ” approach

The “ P ” approach is a helpful guide to remembering the steps in preparing media communication. It was developed by the Population Communication Center at Johns Hopkins University in the United States, and is as follows :

---

### Analysis

- Review potential audiences,
- Assess existing policies and programmes,
- Select sponsoring institutions,
- Evaluate communication resources.

---

## **Design**

Decide on objectives,  
Identify audiences,  
Develop messages,  
Select media,  
Plan for face-to-face reinforcement,  
Draw up action plan.

---

## **Development, pre-testing and revision**

Develop message concepts,  
Pre-test with audience,  
Complete message and materials,  
Pre-test with audience.

---

## **Implementation**

Implement action plan,  
Monitor outputs,  
Measure impact.

---

## **Review and re-planning**

Analyse overall impact,  
Re-plan future activities,  
Adjust for changing audience needs.

## Using popular or people's media for hygiene education

---

### *What are popular media ?*

Traditional or popular media, such as drama, singing, dancing, story-telling and proverb telling, exist in many communities worldwide. Community gatherings, religious meetings and ceremonies can provide opportunities for health education.

The most important characteristic of popular media is that they are enjoyed today. They are living traditions, enjoyed by many people and :

- They are entertaining.
- They cover ideas and issues of universal concern, such as love, marriage, honour, failure, success, jealousy, revenge, wealth, poverty, power, family and group conflicts, and religion.
- Even though they are based on tradition, they change and adapt with the times to deal with new situations and incorporate the issues and concerns of the day.

Folk media that have been used in health education include :

*Story-telling* - both oral and written ;

*Drama* - theatrical performances, participatory theatre and puppets ;

*Song* - pop and traditional song types ;

*Pictures* - art and cloth designs ;

---

### *Story-telling*

Stories are an enjoyable way of learning about subjects. Many countries have a rich oral tradition of stories and legends. Story-telling is a good way of reaching both children and adults. Ideas can be presented in human terms and people can identify with the characters. Stories are an especially good way of introducing ideas about health and hygiene to children.

Stories build on the impact of the spoken word. Abstract ideas can be conveyed in everyday terms. People can identify with the characters and remember the lessons. After telling the story, the audience should be given a chance to discuss the story and ask questions.

---

## *Theatre*

Theatre, or drama, is a valuable approach for hygiene education. Its impact has both a spoken and visual dimension.

In developing stories and dramas, it is important to spend time with the community asking them what they think and feel about the topic. These ideas - and the language that the community use to describe them - can all be put into the drama. One way to get the best impact on hygiene education from theatre is to use the following procedure :

- Have a dialogue with the community ;
- Build into the drama local concerns and issues ;
- Perform the drama at a time when most people can come ;
- Ask questions afterwards to stimulate discussion and to check that the main points are understood.

---

## *Music and dancing*

These can be used on their own or combined with drama for extra impact. Music is an important form of communication in many societies. Music can arouse emotions and strong feelings. Music can be traditional music, where local singers have been directly involved in the selection of songs and words that have both appeal and carry health messages. Some countries have also used modern pop music to appeal to young people. Music can be performed live, but it can also be recorded and played in public places or broadcast on radio.

---

## *Puppets*

Puppets are another form of theatre that can attract a crowd, and be an entertaining way of introducing ideas on health and nutrition. Puppets are a good way of raising sensitive issues surrounding faeces and personal hygiene that might not be acceptable if actors were used in a drama.

---

## *Other popular media*

One good approach is to look around for examples of oral communication in the community. Poetry and proverbs have been used in health education programmes. Traditional medicine sellers, magicians, fortune tellers, town criers and market traders have all been used to get health messages across in interesting and entertaining ways.

---

## General guidelines

Look out for folk and popular media in the community and see whether they can be mobilized for health education. Folk media have enormous potential for health education and health promotion. In using popular media, consider the following :

- Brief the artists, actors and musicians, but let them put the health topics in their own words.
- Any health education carried out through folk media should be based on some initial research on what the community know, feel and believe about the topic. Pre-test any folk media with a sample of the intended audience before using it.
- Involving communities themselves in putting together a drama can be a powerful stimulus for developing community awareness and raising consciousness. It also makes sure that the ideas presented are meaningful and relevant and are more likely to be understood and acted on.
- Performing live in front of an audience has more impact, especially if there is an opportunity for discussion and dialogue between actors and audience. Well planned and properly tested folk media can, however, still have a valuable impact when broadcast through mass media such as film, television and radio and played on audio and videocassettes.
- In using folk media for health, avoid moralizing and preaching. Do not destroy their essential characteristics : their popular nature, their entertainment value, and their ability to deal with social issues.



# Hygiene education for young people

Working with young people involves two groups of activities : school-based and out-of-school activities.

---

## *School-based activities*

Schools can be used for promoting health in three different ways : through improvements in the school environment, provision of school health services and health education.

---

### **School environment**

Children learn from what they see about them. The environment of the school should reflect the aims of the hygiene education programme. This includes the provision of water and toilets, promotion of handwashing, the general cleanliness of the school surroundings, and clean facilities for preparation and serving of school meals.

---

### **Hygiene education in schools**

Hygiene education can take place in the classroom, and through activities in the school surroundings and community. Hygiene education can be taught both as part of a health education programme and as part of other subjects, such as language, mathematics, art, science, music and drama.

Hygiene education should be integrated within a broad-based health education programme that is based on the health needs of the community. This should provide a foundation of ideas about health in the first years of school that can be built upon with more detailed discussion of health and disease with the older school child.

---

## *Examples of hygiene education through different subjects.*

Topic : children should be able to establish the relationship between polluted water and disease.

Oral expression

Telling about the sickness.

Question children about their opinion.

---

## Educational games

Sequence of pictures or comic strips about the different phases of diarrhoea : a child drinks polluted water, has stomach pains, has diarrhoea.

Visits

Go to the health centre, question the nurse.

---

## Mathematical activity

Ask children about diarrhoea among their younger brothers and sisters.

Graphics

Plot the results on a histogram to show how common it is.

Symbolic games

Ask children to draw pictures of themselves when sick.

Drama

Mime sickness in a simple play.

Make puppets and prepare a show.

Play a scene about the disease and how to treat it with oral rehydration solution.

Songs and stories

Make up a song about water and health.

Reading

Read story from Child-to-Child reader about dirty water.

Science - practical activity

Discuss nature of water, salts and sugars.

Make oral rehydration solution up for a child with diarrhoea.

---

## *Recent approaches in school health education*

Hygiene education should do more than just give children facts. Children should be equipped to make decisions, explore attitudes and values, and adopt healthy practices both now and in their future lives. Recent approaches to school health education emphasize the following :

- ***Child-centred approach*** - placing the emphasis on meeting the needs of the children, starting with the child's perception of a healthy lifestyle and recognizing that children learn at different rates.
- ***Active learning methods*** - that encourage exploration and discovery, and relate the information presented to everyday life, bridging the gap between home and community.

- **Problem-solving or issue-based** - learning which organizes the learning around issues or problems, rather than traditional subject disciplines. In this approach, students usually take a health topic and carry out a range of activities in the classroom, at home and in the community. Their finished project might include : songs, drawing, arithmetic, science experiments and story writing.
- **Decision-making methods** - role playing and exercises where children learn to take decisions. This might include role playing where a young person has opportunities to try out different responses to a situation ; for example, a cholera outbreak or case of diarrhoea in the family.
- **Peer teaching methods** - which encourage the use of older respected children as peer models ; for example an older child showing by example the importance of handwashing and using toilets.
- **Teacher-based approaches rather than relying on external visitors** - teachers are in the school all the time and know the children better than visitors. Emphasis should be placed on using the teachers themselves as much as possible, rather than external visitors, to do the health education.

---

## Child-to-Child

The Child-to-Child programme is a global network of organizations promoting activity-based health education in schools. The following are examples of active learning methods for use in schools.

---

### Some Child-to-Child methods for school health education

**Chalk and talk** : using the blackboard or chalkboard ; make lists, for instance of foods at the market ; classify information ; prepare action plans, for instance for a clean-up programme ; write out instructions ; measure things and summarize information on a graph or chart.

**Picture talks** : drawing pictures on a chalkboard or on paper ; cutting out pictures for flannelgraphs, flipcharts and comic books ; story rolls ; asking questions about each picture ; making a mural (large wall painting).

**Story telling** : telling stories in class, at school assemblies or whilst waiting at health centres ; telling stories to younger children ; making pictures to accompany stories ; putting pictures in flipcharts and flannelgraphs.

**Songs** : making up songs about health topics.

**Dramatizations** : acting out stories ; dressing up and performing plays ; using role play to imagine what it is like being in a situation ; making and performing puppet plays for other children and the community.

*Reading and writing* : reading health stories in comics, newspapers, magazines, posters and pamphlets ; writing health stories and messages ; writing letters about local activities ; making health posters ; making record cards ; preparing school newspapers and notice boards.

*Experiments and demonstrations* : making, doing, growing, weighing and measuring things ; observing things, discussing them, telling others about them ; portraying them in dramas, plays, puppet shows or exhibitions.

*Projects and campaigns* : in the school and community.

---

## *Reaching children out of school*

Out-of-school children include :

- School children in their spare time.
- Children who have left school early and are now working, for instance children of poor landless families in rural areas who are needed for daily activities, such as collecting firewood, looking after animals and caring for younger children.
- Children who have never gone to school at all. These could be children orphaned by wars and disease ; deserted by their parents through poverty ; or, also important, the growing numbers of street children in cities of Latin America, Africa and Asia, who earn money from petty trading, parking cars, and in some situations theft and child prostitution.

Young people out of school are among the most difficult groups to reach. If they attend youth clubs or church groups, educational activities can be carried out in these informal locations. Many young people do not, however, attend clubs, and special approaches are needed to reach these groups.

Some promising approaches for working with young people are to :

- Use people that young people look up to, such as singers or football players, to speak on health issues.
- Ask popular music groups to perform songs about health issues.
- Use young people as fieldworkers that youths will listen and respond to.
- Involve young people themselves in producing a drama about their lives and situation.
- Train a group of young volunteers to carry out informal health education in the bars and discos where the young people go.

# Evaluation of hygiene education programme

Evaluation has been defined as “ the systematic and scientific process determining the extent to which an action or set of actions were successful in the achievement of pre-determined objectives. It involves measurement of adequacy, effectiveness and efficiency of health services. ”WHO (1969).

Some important terms used in evaluation are given below :

- *Effectiveness* - whether or not a programme achieves its stated objectives ; that is, did it work ?
- *Efficiency* - the amount of effort in terms of time, staffing, resources and money required to achieve the objectives ; was it worth the effort ?
- *Formative evaluation* - monitoring progress during the programme, involving measurement of intermediate objectives ; that is, what has been achieved so far ?
- *Summative evaluation* - measurement of impact or change at the end of the programme ; have the objectives been achieved ?

So evaluation involves showing that :

- *Change* has taken place.
- The change took place as a *result* of the programme.
- The amount of *effort* required to produce the change was worthwhile.

One reason that evaluation is difficult is that it is often only at the end of a programme that thought is given to how the programme should be evaluated. It is important to plan at the beginning how to evaluate the work.

---

## *Communication stages and evaluation*

By asking the questions listed below, it is possible to find out at which stage a failure in communication took place. The fault can then be corrected and the programme improved.

---

## *Questions to ask when evaluating communication activities*

---

### **Were the communication activities carried out ?**

How many radio programmes were broadcast ; talks or training sessions given ; community meetings held ; leaflets distributed ; posters put up ?

---

### **Did the intended audience see or hear the message ?**

How many people saw the posters ; were able to receive the radio broadcasts ; came to the talks ; passed by the exhibition ?

---

### **Did the intended audience pay attention to the communication ?**

What was the coverage of the programme - how many people saw the poster ; listened to the radio programme ; stopped to look at the exhibition ; were paying attention at the meeting ?

---

### **Did the intended audience understand the messages ?**

How many people could correctly repeat back the messages of the posters, radio programmes, talks, meetings ?

---

### **Did it convince the audience ?**

How many people accepted and believed the message ?

---

### **Did it result in a change in behaviour ?**

How many people changed their behaviour as a result of the communication ?

---

### **Did it lead to improvements in health ?**

How many people's health improved as a result of the programme ? What changes in the level of disease incidence or prevalence took place ?

It is best to be realistic when selecting changes to be measured in an evaluation. Changes in knowledge, understanding, awareness and belief might take place soon after the communication. Changes in behaviour and health, however, usually take longer. It is a good idea to carry out a *short-term evaluation* fairly soon after the activity and a *follow-up evaluation* later to look for long-term changes.

---

## *Choice of indicators for evaluation of diarrhoea programmes*

---

### **Health outcome**

- mortality from diarrhoea ;
- morbidity from diarrhoea.

---

### **Behaviours**

- disposal of faeces ;
- water handling ;
- breast-feeding ;
- oral rehydration therapy.

---

### **Preconditions for behaviour change**

- ability to prepare oral rehydration solution ;
- recognition of symptoms of cholera ;
- belief that dehydration is dangerous ;
- acceptance of importance of oral rehydration therapy ;
- exposure to education on cholera ;
- knowledge of cholera control measures.

---

## *Showing that change took place because of your programme*

If the objectives have been clearly defined at the outset it is not usually difficult to show that change has taken place in a community. It is, however, much more difficult to show that it took place *because of the programme's intervention and efforts*, and not for some other reason. There are two ways of showing that change was caused by the programme's intervention (this is called proving causality).

---

### **Using controls**

Another group can be set up, for instance another classroom, group of mothers, or village, as a **control group** who do not receive the education. The two groups should be as close as possible in age, education and income. If the group that received the educational programme achieves a better performance than the control group, this will provide strong evidence for the success of the communication activities.

---

### **Indirect method without controls**

If it is not possible to set up a control group, an indirect method will have to be used for excluding other reasons for any changes. One way is to look carefully at what has taken place - could there be any other possible explanation for the changes that took place? Another way is to interview samples of the community and ask them why they changed their behaviour - was it because of the activities or were there other reasons that were unrelated to the activities?

---

### *Two approaches to evaluation*

Evaluation may be carried out in two ways, as indicated below.

Using controls

- Measure baseline at the beginning (“pre-test”).
- Test group receives education.
- Control group does not receive education.
- Measure levels at the end of the programme (“post-test”) of test group and control group.

---

### **Indirect evaluation without a control**

- Measure baseline at the beginning.
- Give education.
- Measure levels at the end. Ask questions to find out why people changed and find out if it was because of educational efforts.

*Participatory evaluation.* Involvement of the community in evaluation helps to create a bond of trust with the community. It gives an opportunity to find out their feelings about the benefits and weaknesses of the activities, and to draw on their experiences and insights on what has happened. Evaluation becomes a learning process, and the community are able to reflect on their experiences and plan future activities.

---

### *Summary guidelines for evaluation*

- Decide at the beginning of a programme how it is going to be evaluated.
- Prepare a set of realistic, achievable and measurable indicators for success. Consult employers, funding bodies and the community when deciding on objectives.



- Wherever possible, set up control groups who do not receive the education. Make sure that these controls are similar to the test community. If controls are not possible, collect data that will help to show that it was the education that led to improvements.
- Look for changes in the short term as well as the long term. Find out if any benefits are long-lasting.
- Do not limit the evaluation to just finding out if the objectives have been achieved - look out for any unplanned benefits or unexpected problems.
- Look out for ways of involving the target groups in all stages of the evaluation process, including setting objectives, collecting data, judging outcomes and deciding on future activities.
- Learn from failures as well as successes. Find out why programmes succeeded or failed and what lessons can be drawn for the future.
- Share the successes or failures with others. Tell others about what has been done ; circulate any reports and look out for newsletters and journals to send articles to for publishing.