

TED

Technologies
for Economic
Development



BORDA



www.ted-biogas.org
www.borda-sadc.org

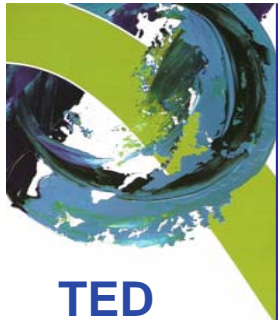

TED

Technologies
for Economic
Development



BORDA



www.ted-biogas.org
www.borda-sadc.org

Decentralized Wastewater Treatment



DEWATS is an approach, rather than a hardware package

Guided by following principles:

- Reduce sewer networks
- Simplify sewer by applying **SOLID-FREE SEWER**
- Involve **local labour and material** available
- Construct what requires **low maintenance and no energy**
- Generate **Biogas for energy**
- Generate **water and nutrients for irrigation** in agriculture and food-garden

Applicable for households, settlements, institutions, hospitals, schools,...and small and medium sized enterprises (SME) for the treatment of domestic and organic industrial wastewater

→ Up to 2,000 households per DEWATS unit



TED

Technologies
for Economic
Development



BORDA



www.ted-biogas.org
www.borda-sadc.org

DEWATS fills a Gap

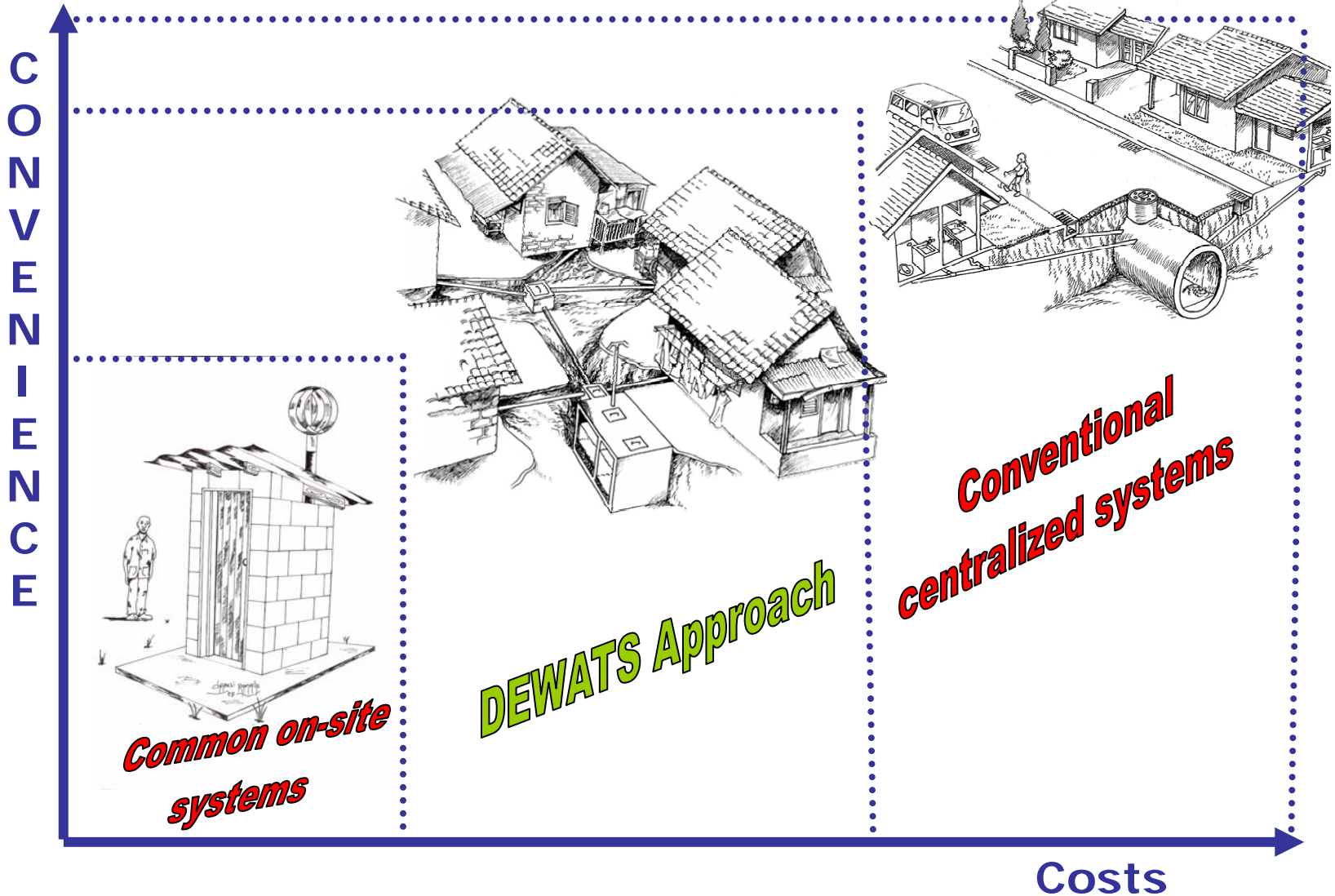

Common on-site systems

DEWATS Approach

Conventional centralized systems

Costs



TED

Technologies
for Economic
Development



BORDA



www.ted-biogas.org
www.borda-sadc.org

Decentralized Wastewater Treatment

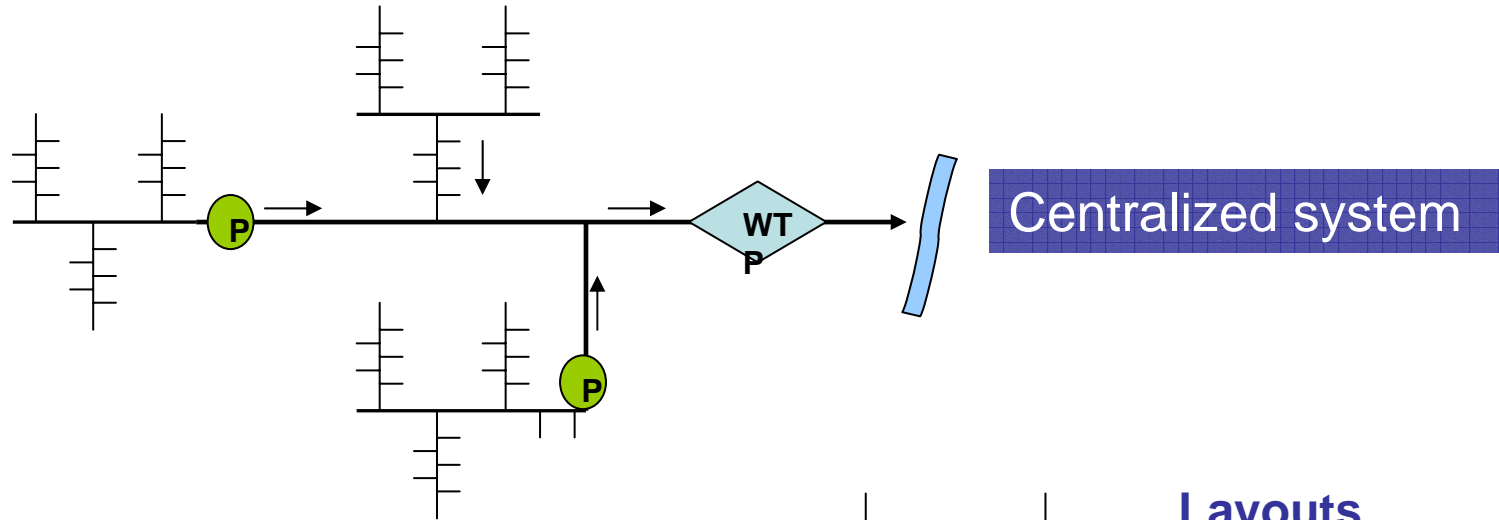

Single House

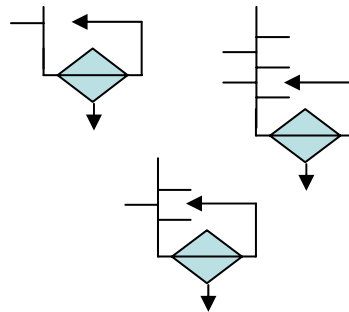

Decentralized system

Layouts

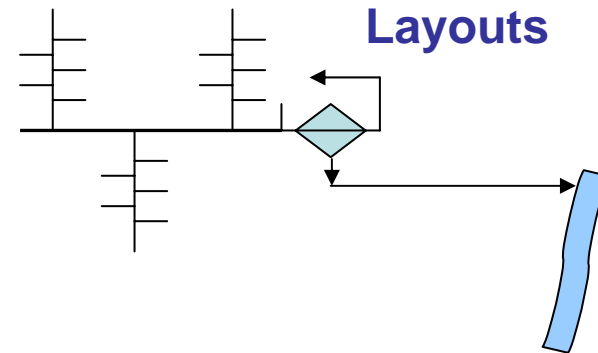

Housing Colony



TED

Technologies
for Economic
Development



BORDA



www.ted-biogas.org
www.borda-sadc.org

Decentralized Wastewater Treatment



Advantages-Decentralization

- ★ Is beneficial from the point of construction & maintenance of sewer system
- ★ Size of sewer pipe and depth of construction is lesser, hence not expensive
- ★ Re-use of the treated wastewater in agriculture and food garden
- ★ Integration of local construction & operation capacities and job creation
- ★ Collection and utilization of biogas for cooking and heating

Disadvantages-Decentralization

- ★ More maintenance on decentralized level
- ★ Cost and area required for the treatment infrastructure is more

Compare investment and O&M cost of a decentralized and centralized approach

...and then decided for your project

Decentralized Wastewater Treatment

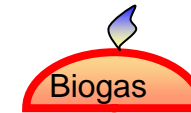

Sanitation with biogas & water recycling

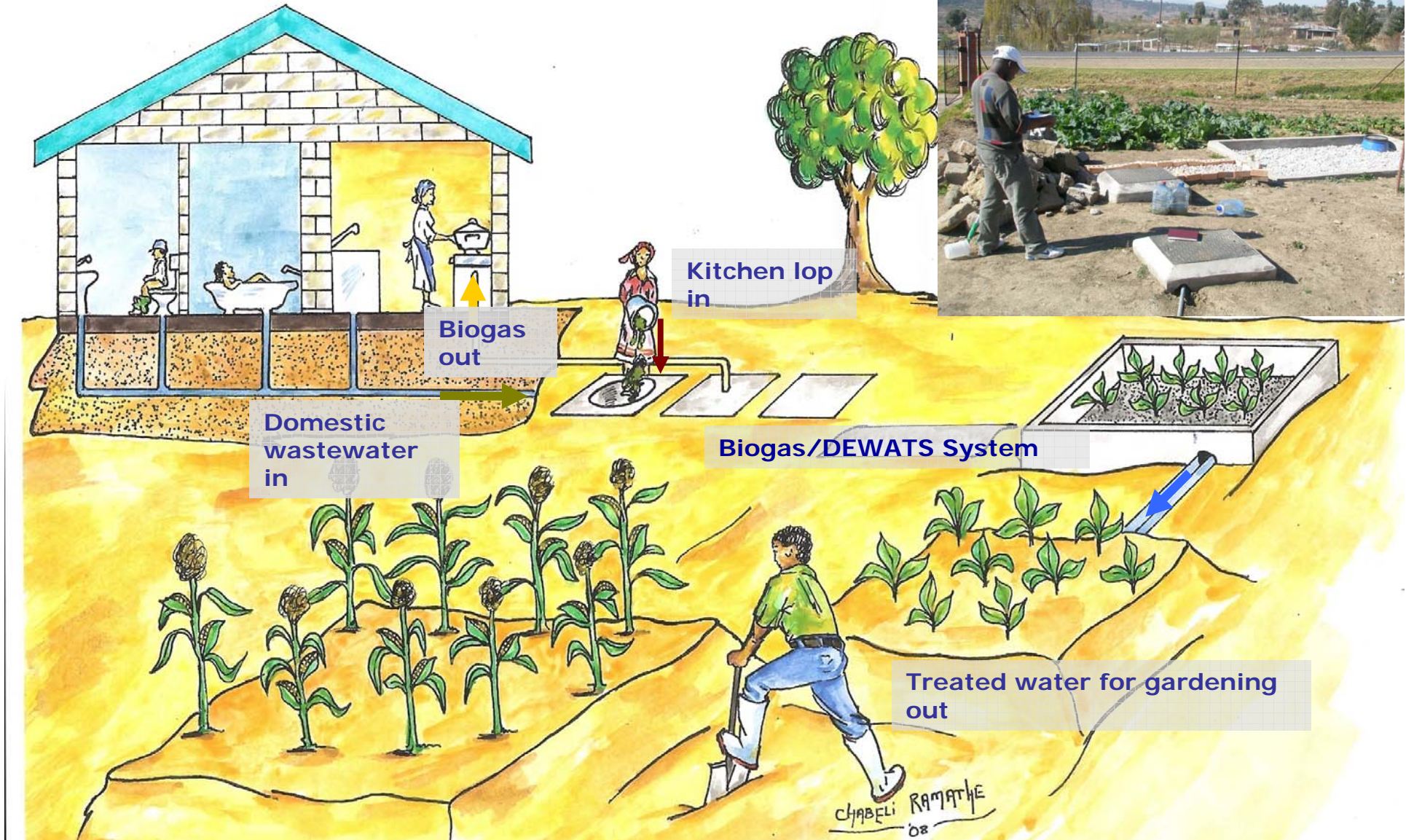



TED

Technologies
for Economic
Development



BORDA



www.ted-biogas.org
www.borda-sadc.org

Decentralized Wastewater Treatment

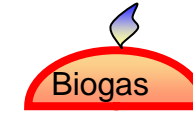

DEWATS modules

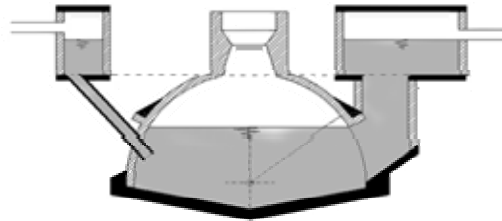

biogas plant

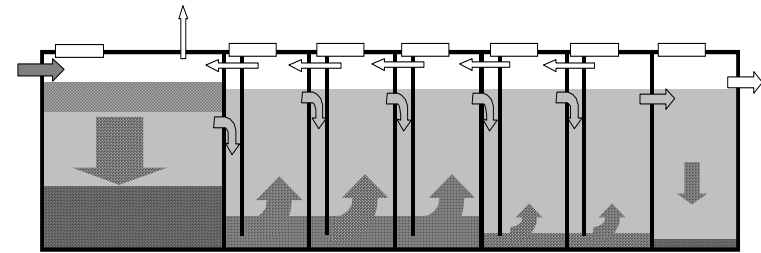

anaerobic baffled reactor

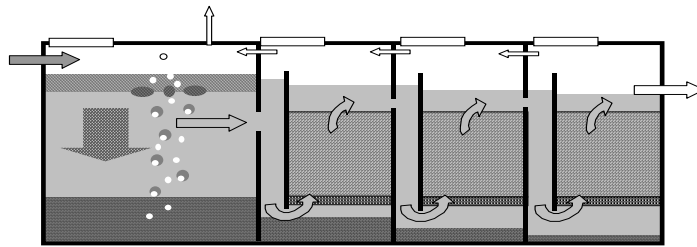

anaerobic filter

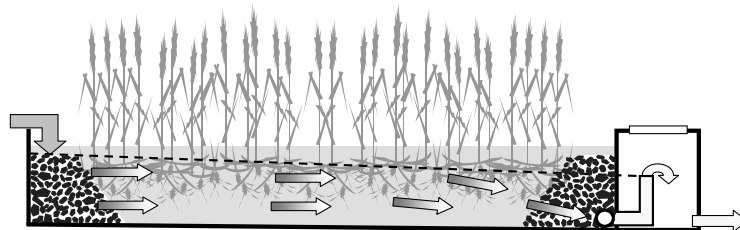

planted gravel filter





Decentralized Wastewater Treatment

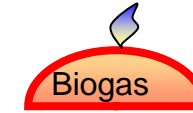

DEWATS effluent quality

TED

Technologies for Economic Development



www.ted-biogas.org
www.borda-sadc.org

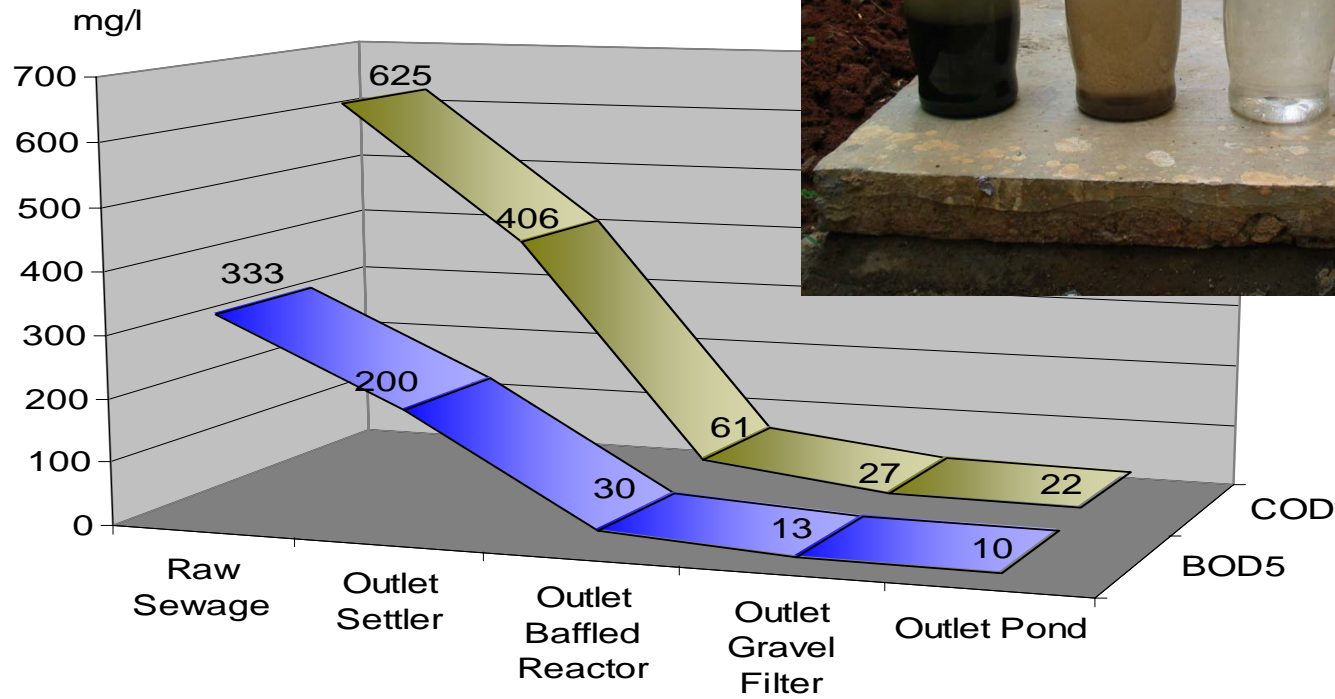

Decentralized Wastewater Treatment

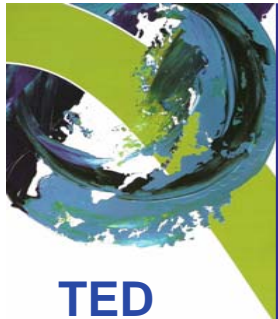
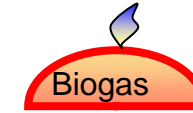

TED

Technologies
for Economic
Development



www.ted-biogas.org
www.borda-sadc.org

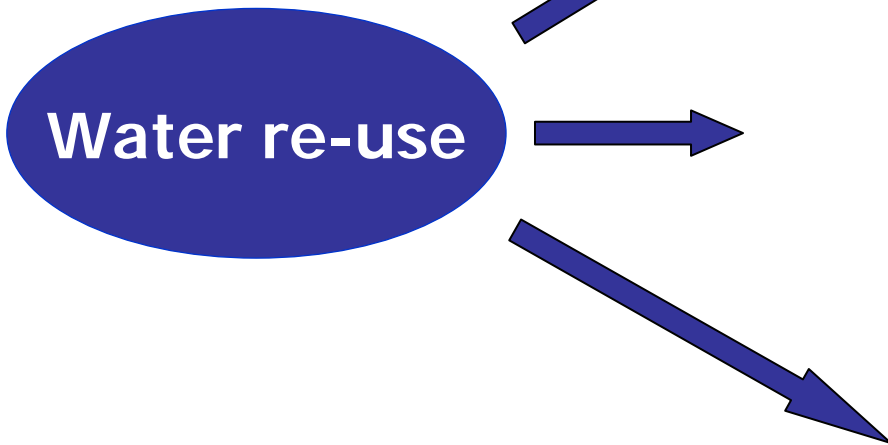



TED

Technologies
for Economic
Development



BORDA



www.ted-biogas.org
www.borda-sadc.org

Decentralized Wastewater Treatment

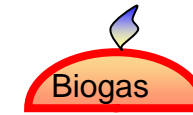

- Biogas yield 8 – 10 l per capita per day
- Gas pressure 30 – 100 cm water column
- Biogas consumption of a ordinary one flame stove 300 l per h
- Applicable for cooking and heating lightning

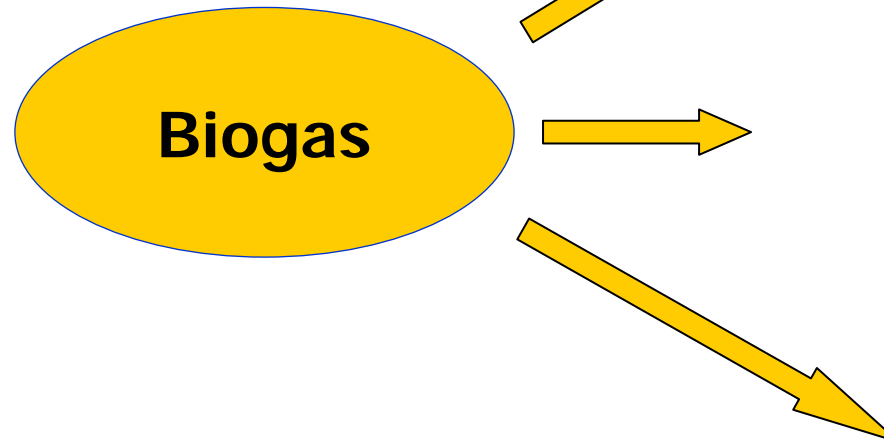

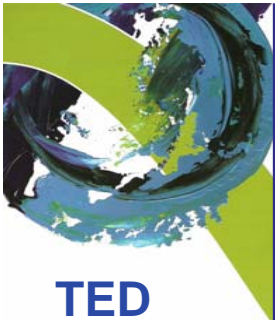

TED

Technologies
for Economic
Development



BORDA



www.ted-biogas.org
www.borda-sadc.org

Decentralized Wastewater Treatment

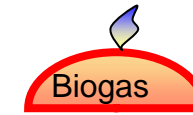

DEWATS figures

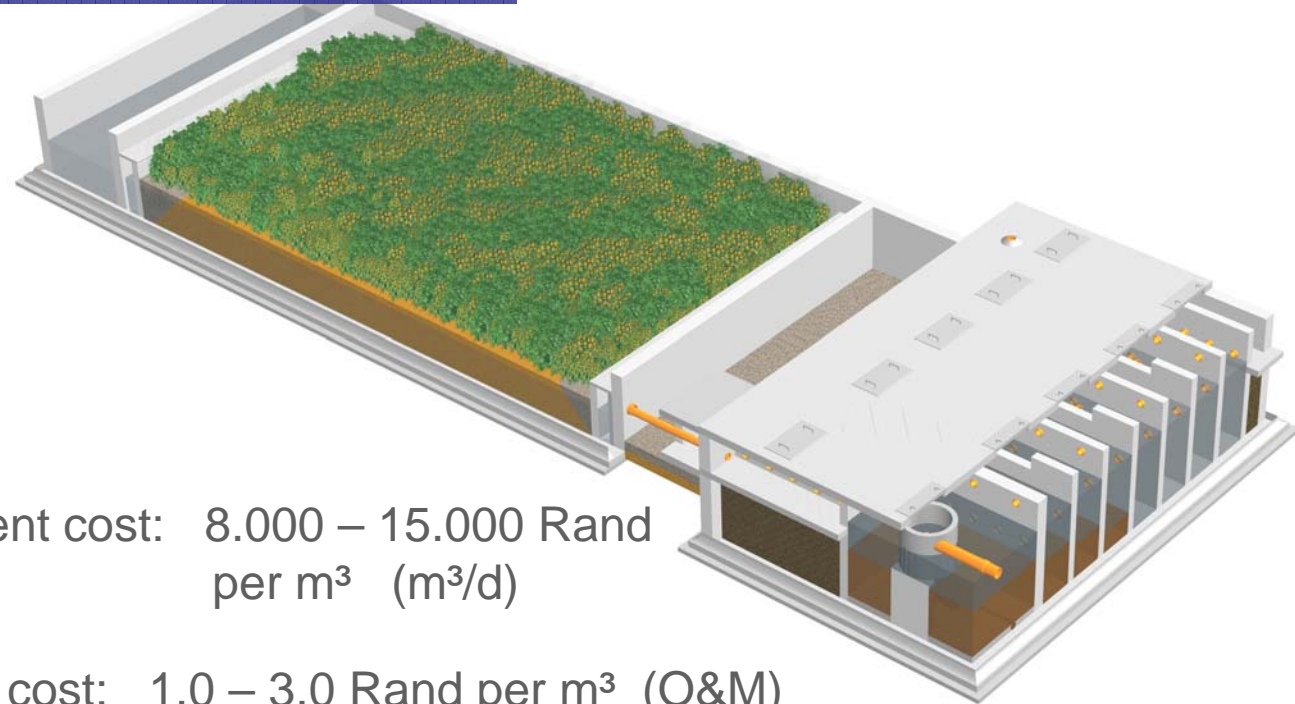

Investment cost: 8.000 – 15.000 Rand
per m³ (m³/d)

Running cost: 1,0 – 3,0 Rand per m³ (O&M)

Required area: 10 – 25 m² per m³

Type of wastewater: domestic, organic food industry WW

Treatment capacity per unit: up to 150 m³ per day

Life time: 30 – 40 years

Decentralized Wastewater Treatment

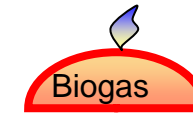

TED

Technologies
for Economic
Development



BORDA



Construction of Biogas plants



www.ted-biogas.org
www.borda-sadc.org



Decentralized Wastewater Treatment

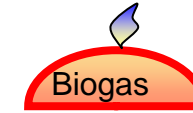

TED

Technologies
for Economic
Development



BORDA



Biogas/DEWATS plants for households



www.ted-biogas.org
www.borda-sadc.org



Decentralized Wastewater Treatment

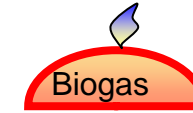

TED

Technologies
for Economic
Development



BORDA



Construction of ABR reactors for institutions and settlements

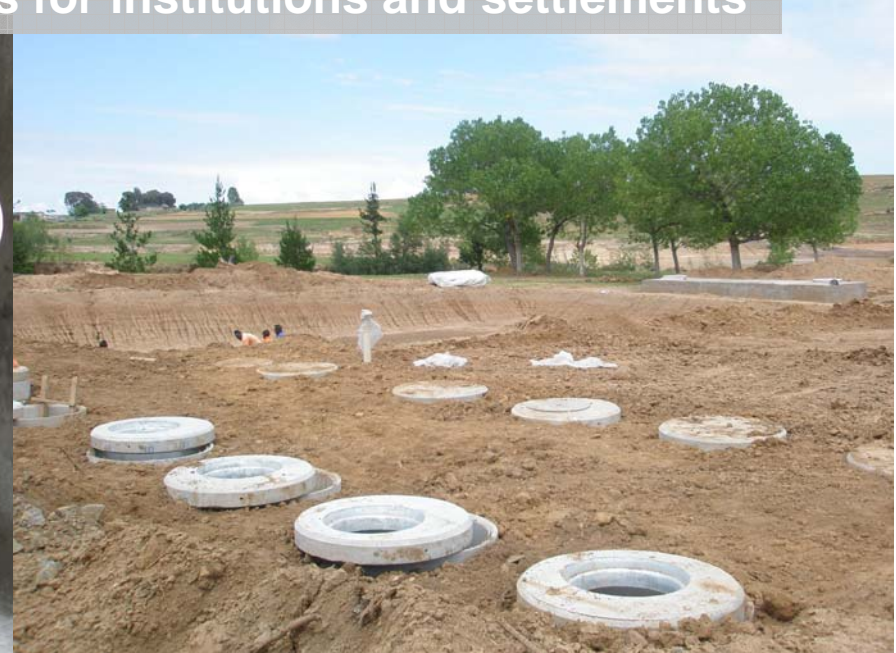



Decentralized Wastewater Treatment

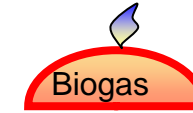

TED

Technologies
for Economic
Development



BORDA



Construction of horizontal filter (PGF) for institutions and settlements





TED

Technologies
for Economic
Development



www.ted-biogas.org
www.borda-sadc.org

Decentralized Wastewater Treatment



References

- Lesotho 28 Biogas/DEWATS plants for 6-2,000 people are constructed and in operation; 6 plants in planning
- South Africa 2 DEWATS plants in planning (Durban and Waterberg)
- Zambia > 20 Biogas/DEWATS plants in planning
- World wide more than 700 DEWATS plants for operation through the BORDA network



TED

Technologies
for Economic
Development



BORDA



www.ted-biogas.org
www.borda-sadc.org

DEWATS pilot project at Newlands Mashu / Durban



A cooperation project with eThekweni Municipality (EWS), UKZN & Newlands Mashu

Goals: → Piloting DEWATS and → agriculture research on treated wastewater

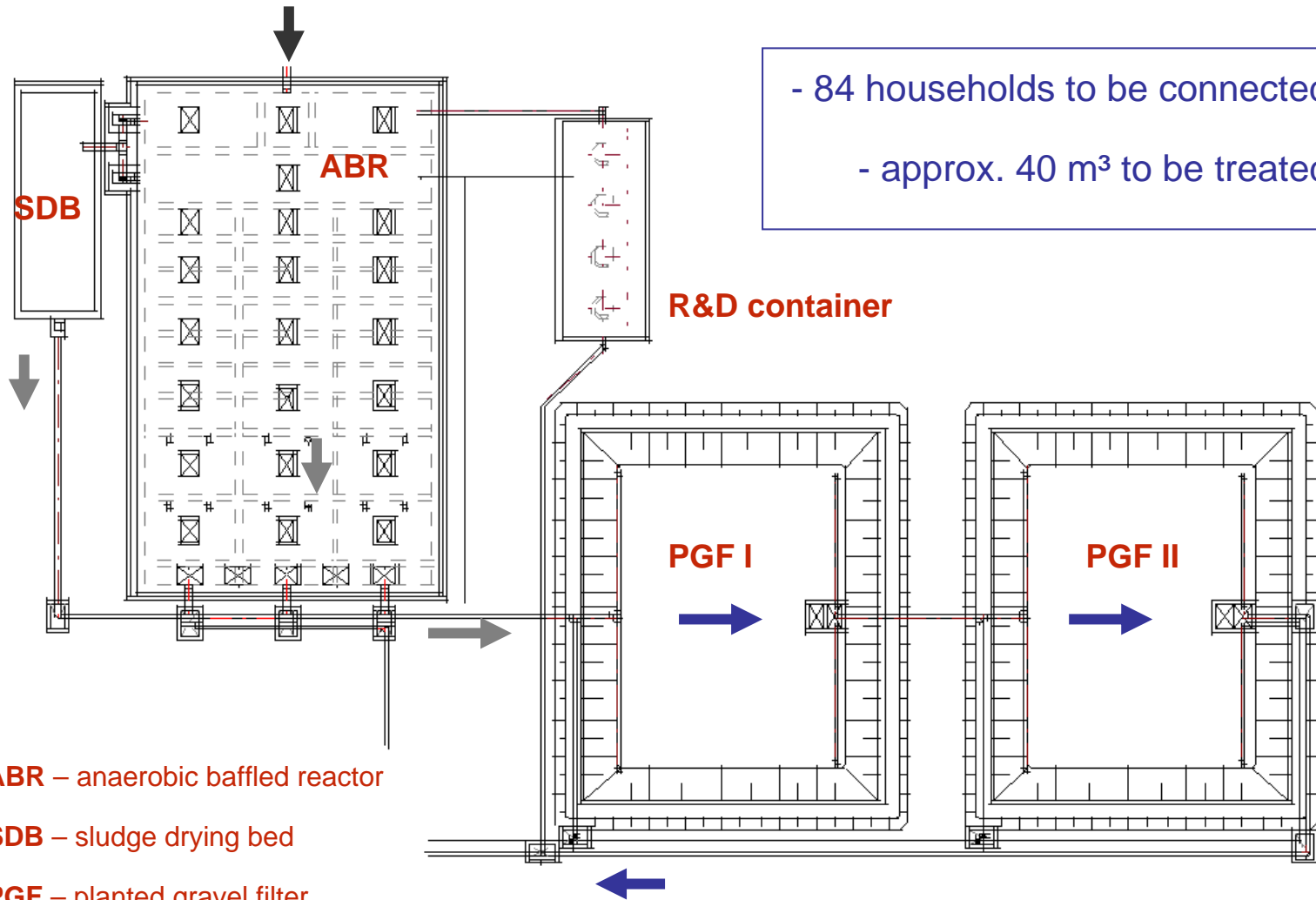



Technologies
for Economic
Development



www.ted-biogas.org
www.borda-sadc.org

BORDA Head Office

Industriestr. 20
28199 Bremen

fon: +49 421 137 18
fax: +49 421 165 5323
eMail: office@borda.de
Internet: www.borda-net.org

BORDA-SADC

TED-BORDA Project Office
P.O. Box 1172
100 Maseru, Lesotho
+266 2232 5621
+266 2232 5621
schmidt@borda.de
www.borda-sadc.org

„Thinking long-term - Acting Now“