

Rural Water Supply Technology Options

Handpumps, Mechanised Pumps and Surface Water

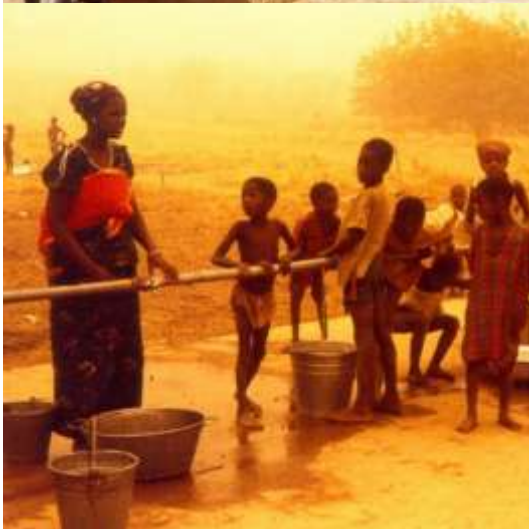

Handpumps

Included in the chapter of Handpumps (Human Powered Pumps) are:

Reciprocating Handpumps

- A) **Suction Pumps**
 - A1) No. 6 Pump
- B) **Direct Action Pumps**
 - B1) MALDA Pump
 - B2) NIRA AF-85
 - B3) TARA Pump
- C) **Lever Action Pumps**
 - C1) JIBON Pump
 - C2) WALIMI Pump
 - C3) INDIA Mark II Pump
 - C4) INDIA Mark III Pump
 - C5) U3M Pump
 - C6) AFRIDEV Pump
 - C7) BUSH Pump
 - C8) VOLANTA Pump

Rotary Handpumps

- A) **ROPE Pumps**
 - A1) Nicaragua ROPE Pump
 - A2) Madagascar ROPE Pump

Displacement Handpumps

- A) **Diaphragm Pumps**
 - A1) VERGNET Hydropump
 - A2) Progressive Cavity Pumps

Technology Selection

Motorized Pumps

- Submersible Pumps
- Line Shaft Pumps
- Jet Pumps
- Solar powered Pumps
- Wind powered Pumps

Surface Water

- Rainwater
 - Rainwater Harvesting
 - Rainwater Storage
- INTake Structures for Rivers, Lakes and Dams
 - Direct Intake
 - Infiltration Intake
 - Bottom Intake
 - Side Intake
 - Floating Intake

For more information:

check the RWSN Website www.rwsn.ch
or send your enquiry to RWSN@skat.ch

Reciprocating Hand Pumps

The majority of handpump types used world-wide belong to the group of the **Reciprocating Pumps**. The water is lifted by a piston that is raised and lowered inside a valved cylinder. The piston (or plunger) is moved by a pumprod connected directly to a T-handle or a Lever handle at the pump head. In some pump types, a flywheel with crankshaft is used to create the reciprocating movement of the piston. Included in the group are reciprocating handpumps are:

- A) Suction Pumps
- B) Direct Action Pumps
- C) Lever Action Pumps

The function of the reciprocating pumps is caused by the principle that water flows from areas of high pressure to areas of low pressure. The reciprocating pumps create an area of sufficiently low pressure above the body of water, thus causing it to flow upward.

A reciprocating piston pump consists essentially of a long vertical pipe, called rising main. This rising main extends into the cylinder (the area in which the piston/plunger moves up and down). Near the bottom of the cylinder, a non-return valve is fitted, called footvalve. The footvalve allows the water to flow from the lower part of the pump into the cylinder, but prevent it from flowing back into the well.

A second non-return valve is situated in the piston/plunger. The piston/plunger and the footvalve will alternatively divide the pump into an upper part or a lower part. The lower part of the pump always extends into water body of the well.

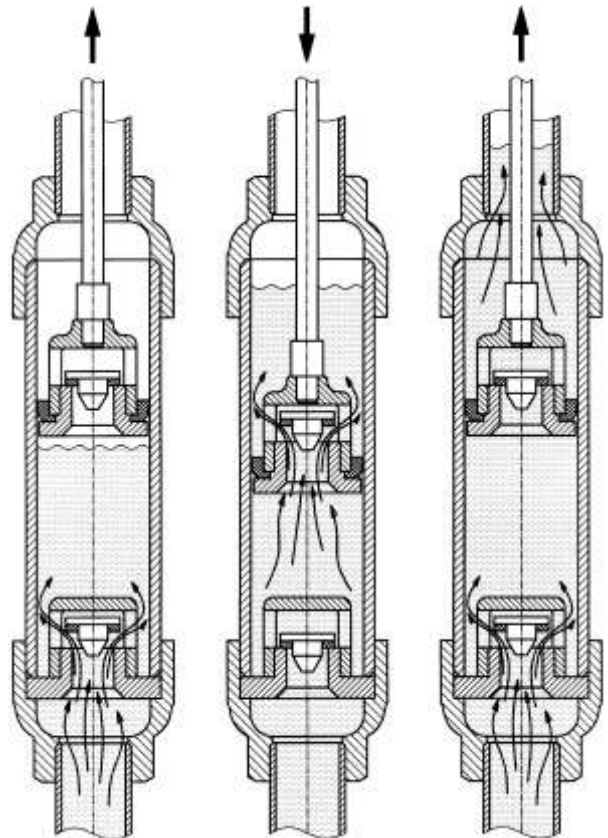

When the operator lowers the piston, the atmospheric pressure acts equally on all water surfaces.

The footvalve stays closed preventing water from being pushed back into the well. The non-return piston valve opens allowing water to flow through the piston. The piston presses down on to the water until it gushes up through the valve in the piston. At the lowest point of the stroke, the movement of the piston is reverted. The pressure of the water column above the piston causes the piston valve to close. This effects two things:

- a) The water above the piston starts rising. It can not flow backwards and will rise in the rising main until it reaches the top of the pump; flowing out by the spout, and
- b) Because the piston stops pressing on the water below it, the pressure in the lower part of the cylinder drops; a vacuum is created. The water in the well is still under atmospheric pressure and will push its way past the footvalve into the cylinder.

A) Suction Pumps

In a “suction” pump, the cylinder is above the water table, usually near the top of the pump head.

The rising main extends below the water table.

When the pump is operated, during the upwards stroke it appears that water gets “sucked up” through the rising main into the cylinder.

In fact, the atmospheric pressure forces the water into the area of low pressure underneath the piston.

The theoretical limit to which the atmospheric pressure can push up water is 10 meters. In practice, suction pumps can be used to lift water up to about 7 to 8 meters.

A suction pump needs to be full of water before it can be operated. That means the pump need to be primed.

In regular practice, water has to be pored into the pump head by the operator, every time the pump is emptied by a leaking footvalve.

Thus, the danger exists that the well can be contaminated through polluted water used for priming.

The advantage of suction pumps is that the cylinder is normally above the level of the soil (above ground).

For maintenance, the replacement of seals and valves can be easily performed with few tools.

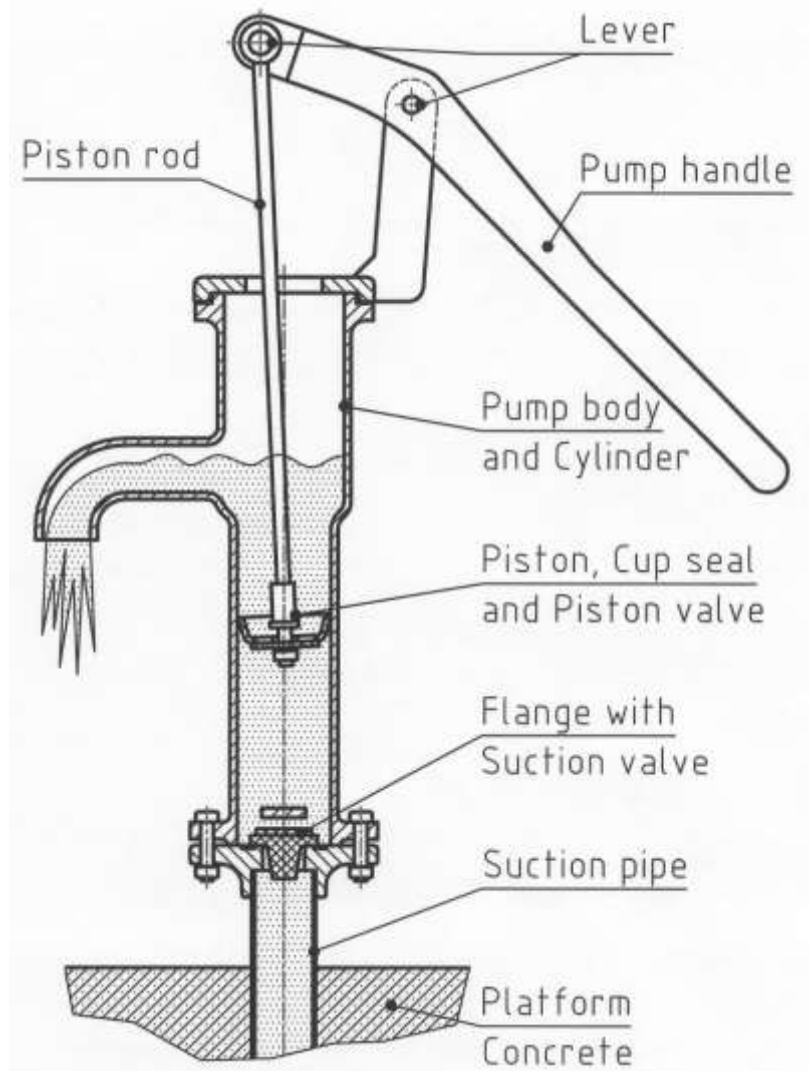

A1) No. 6 Pump

Description

The No 6 Pump is lever operated suction handpump. Typically, No 6 Pumps are installed in collapsible tube wells with the screen extending to the coarse sand aquifer.

Technical data

Cylinder diameter:	89.0 mm
Maximum Stroke:	215 mm
*) Approx. discharge, (75 watt input, at 5 m head)	4.5 m ³ /hour
Pumping lift:	0 - 7 m
Population served:	50 - 100 people
Households:	5 - 10 households
Water consumption:	20 - 25 l/per capita
Type of well:	collapsible tube well or dugwell



Material

Pump head, handle and cylinder are cast iron, pump rods are of mild steel, suction pipe is of PVC pipe, Plunger and check valve are of brass. This makes the No. 6 Pump reasonably corrosion resistant.

Local manufacturing

The No 6 Pump has an excellent potential for local manufacturing.

Installation

The installation of the No 6 Pump is easy and does not need any lifting equipment or special tools. The drillers who sink the tube well with the "sludger method" also install the pump.

Maintenance

This pump has an excellent "Community Management Potential". Only two spanners are needed to repair plunger and footvalve. A village caretaker can perform all maintenance operations.

Remarks

This pump is like all Suction pumps limited to pumping lifts of a maximum of 8 m. It is recommended not to go deeper than 6-7 m. The No 6 Pump is not designed for a high daily output, but rather a family or small community pump.

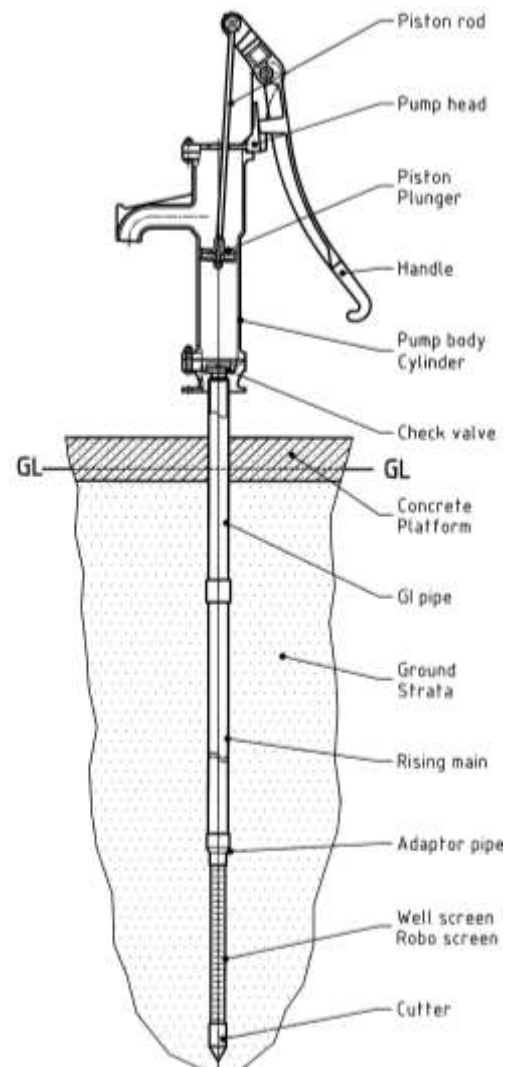

B) Direct Action Pumps

In most direct action handpump designs, the up and down movement of the piston is made by the pumprod with a T-handle directly connected at the upper end. The "pumprod" is made of plastic pipes, which are connected by threads and each pipe length is sealed air-tight. With this system, the pumprod pipes are floating in the water of the rising main and therefore reducing the force needed on the up-stroke. Because of the narrow clearance in diameter between pumprod and rising main (approx. 6 to 10 mm), the pumprod is displacing water during the down-stroke. This gives the advantage of a water delivery during up- and down-stroke.

Direct action pumps are very simple to handle by the community. Once the riser pipes and pumprod pipes are connected, disconnection for maintenance is not required because these pipes are flexible enough to be pulled from the well or borehole in a big bow.

All "down hole components" are made of plastic with few rubber parts, which makes the installation easy (light-weight) and completely corrosion resistant to aggressive waters.

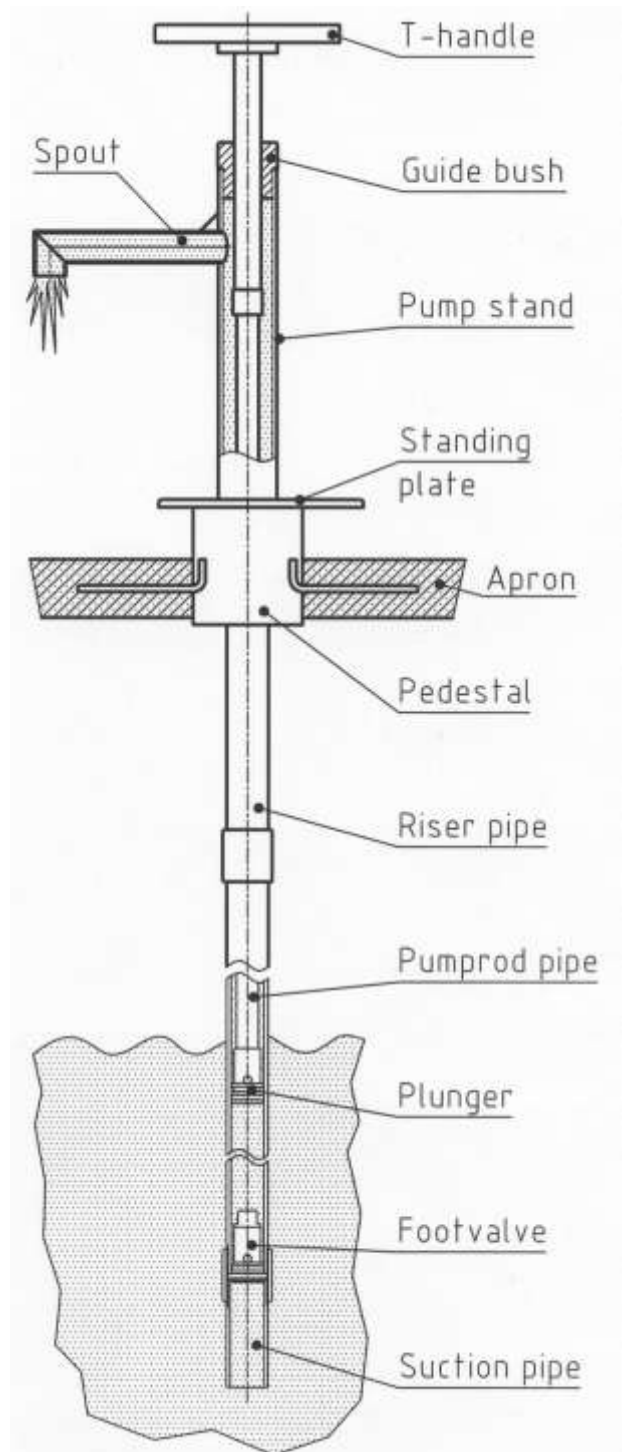

B1) Malda Pump

Description

The MALDA Pump as a direct action pump is based on a buoyant pump rod that is directly articulated by the user, discharging water at the up- & down stroke.

Technical data

Cylinder diameter:	50 mm
Maximum Stroke:	410 mm
*) Approx. discharge,(75 watt input)	
at 5 m head:	3 m ³ /hour
at 10 m head:	1.8 m ³ /hour
at 15 m head:	1.2 m ³ /hour
Pumping lift:	1 - 15 m
Population served:	- 300 people
Households:	30 households
Water consumption:	15 - 20 l/per capita
Type of well:	borehole or dugwell



Material

Pump stand, standing plate and handle are made of galvanized steel, wearing sleeve of stainless steel, pump rods and rising main of HDPE pipe and plunger & footvalve are also made of HDPE. This makes the MALDA Pump completely corrosion resistant.

Local manufacturing

The MALDA Pump is specially designed to be produced in various developing countries.

Installation

The installation of the MALDA Pump is very easy and does not need any lifting equipment or special tools. The rising main with footvalve and pump head as well as the pump rod with handle and plunger can be assembled on the ground. When laid next to each other, the correct length can be checked. For installation both, rising main and pumprod do not need to be dismantled again.

Maintenance

This pump has an excellent "Community Management Potential". Only simple tools are needed to pull out the entire pumping element as well as footvalve and rising main.

Remarks

This pump is like most of the "Direct Action Pumps" (DAP) limited to pumping lifts of a maximum of 15 m. It is recommended not to go deeper than 12 m.

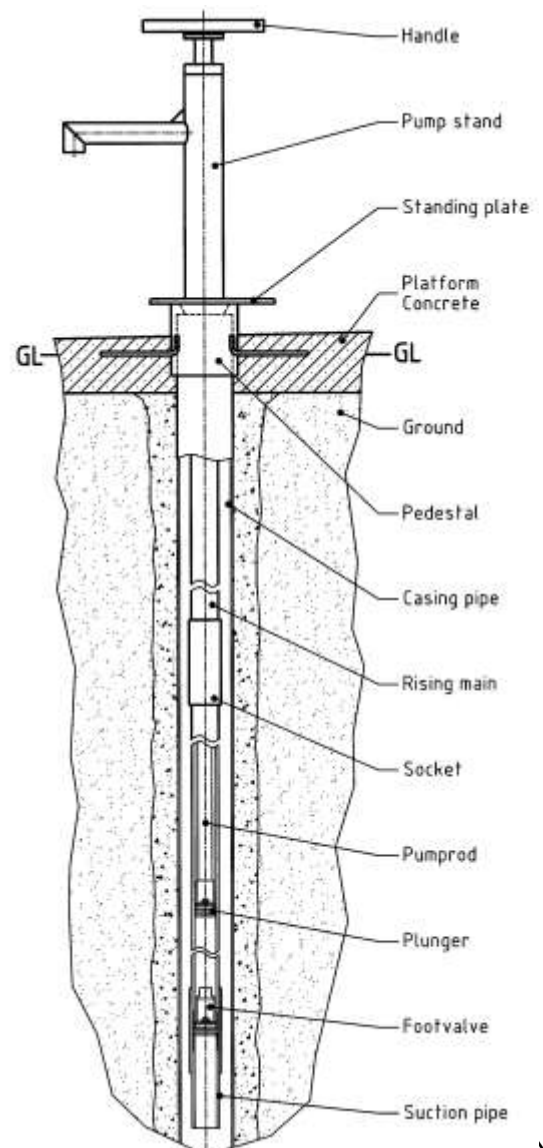

B2) NIRA AF-85 Pump

Description

The NIRA AF-85 Direct Action Handpump is based on a buoyant pump rod that is directly articulated by the user, discharging water at the up- & down stroke. The NIRA AF-85 Pump is completely corrosion resistant.

Technical data

Cylinder diameter:	50 mm
Maximum Stroke:	410 mm
*) Approx. discharge,(75 watt input)	
at 5 m head:	3 m ³ /hour
at 10 m head:	1.8 m ³ /hour
at 15 m head:	1.2 m ³ /hour
Pumping lift:	1 - 15 m
Population served:	- 300 people
Households:	30 households
Water consumption:	15 - 20 l/per capita
Type of well:	borehole or dugwell

Material

Pump head and standing plate are made of galvanized steel and the handle of stainless steel. Pump rods and rising main are made of HDPE pipe, plunger and footvalve of HDPE material. This makes the NIRA AF-85 Pump completely corrosion resistant.

Local manufacturing

The NIRA AF-85 Pump is a protected product and is not intended for local production. Although, besides the main company in Finland, there is one branch in Ghana (Ghanira) and one in Tanzania (Tanira) producing this pump.

Installation

The installation of the NIRA AF 85 Pump is easy and does not need any lifting equipment or special tools.

Maintenance

This pump has an excellent "Community Management Potential". Only simple tools are needed to pull out the entire pumping element as well as the footvalve and rising main. This pump is reliable and popular with the communities.

Remarks

This pump is like most of the "Direct Action Pumps" (DAP) limited to pumping lifts of a maximum of 15 m. It is recommended not to go deeper than 12 m.

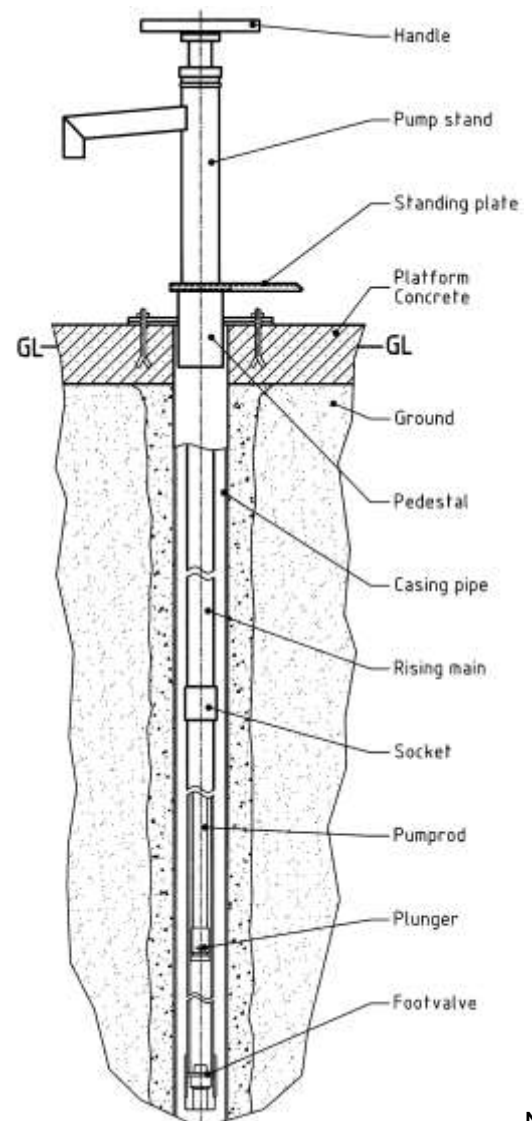

B3) TARA Pump

Description

The TARA Pump as a Direct Action Handpump is based on a buoyant pump rod that is directly articulated by the user, discharging water at the up- and down stroke. TYPICALLY, TARA pumps are installed in collapsible tube wells with the screen extending to the coarse sand aquifer.

Technical data

Cylinder diameter:	54.2 mm
Maximum Stroke:	600 mm
*) Approx. discharge,(75 watt input)	
at 5 m head:	3.5 m ³ /hour
at 10 m head:	1.8 m ³ /hour
at 15 m head:	1.2 m ³ /hour
Pumping lift:	1 - 15 m
Population served:	- 100 people
Households:	10 households
Water consumption:	15 - 20 l/per capita
Type of well:	borehole or dugwell

Material

Pump head and handle galvanized steel, pumprods, rising main and cylinder PVC pipe, plunger, footvalve of different materials
The TARA Pump is corrosion resistant.

Local manufacturing

The TARA Pump has an excellent potential for local manufacturing.

Installation

The installation of the TARA Pump is easy and does not need any lifting equipment or special tools. Drillers who sink the tube wells with the “sludger method” are also installing the pumps.

Maintenance

This pump has an excellent “Community Management Potential”. Only simple tools are needed to pull out the entire pumping element and the footvalve. A village caretaker can perform all maintenance operations.

Remarks

This pump is like most of the “Direct Action Pumps” (DAP) limited to pumping lifts of a maximum of 15 m. It is recommended not to go deeper than 12 m. The TARA Pump is not designed for a high daily output, but rather a family or small community pump.

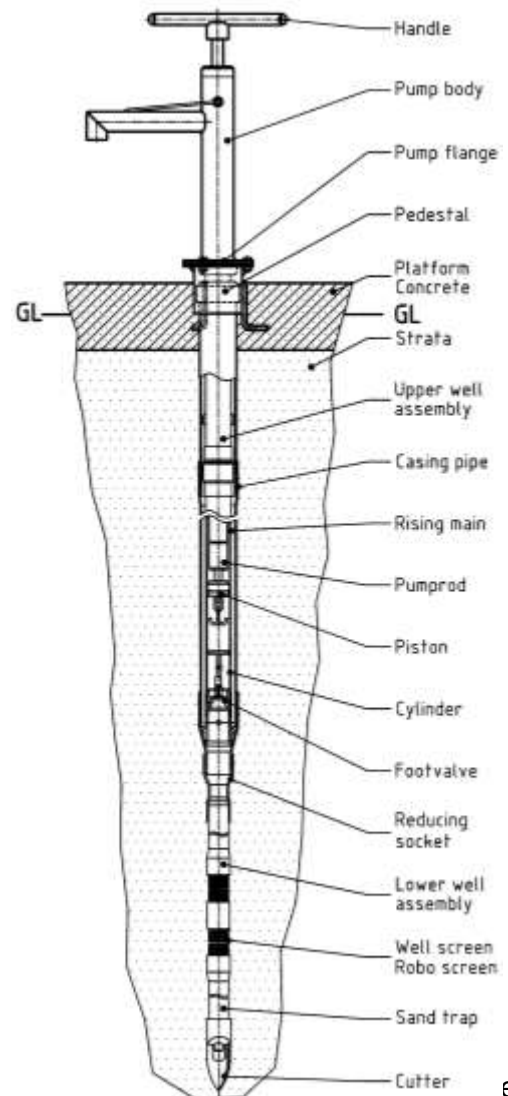

C) Lever Action Pumps

Deepwell handpumps are normally conventional lever action pumps. The increasing length of the water column requires more effort to draw water and the lever of the handle makes the operation easier.

Besides the conventional handle, there are also pump designs, which are using a flywheel to operate a crank shaft for transforming the rotation into an “up- and down” movement.

Lever action pumps consist of

- a) above ground components like pump head, pump stand and handle, which are usually of welded mild steel components, preferably with a corrosion protection of hot-dip-galvanized zinc layer and
- b) down hole components like rising main, pumprods with plunger, cylinder and footvalve.

The configuration of the down hole components can include an “open top cylinder”; the plunger and the footvalve can be removed from the cylinder without dismantling the rising main – or they can feature the conventional configuration with a small diameter rising main and a bigger cylinder diameter, which requires dismantling of the rising main for repairs on plunger or footvalve.

Riser pipes are made of GI pipes, PVC-U or stainless steel.

Pumprods are made of mild steel, stainless steel or fibre reinforced plastic rods (FRP).

Joining of pumprods is preferably made with threaded connections. Pumping elements like plunger and footvalve are made of brass or engineering plastics.

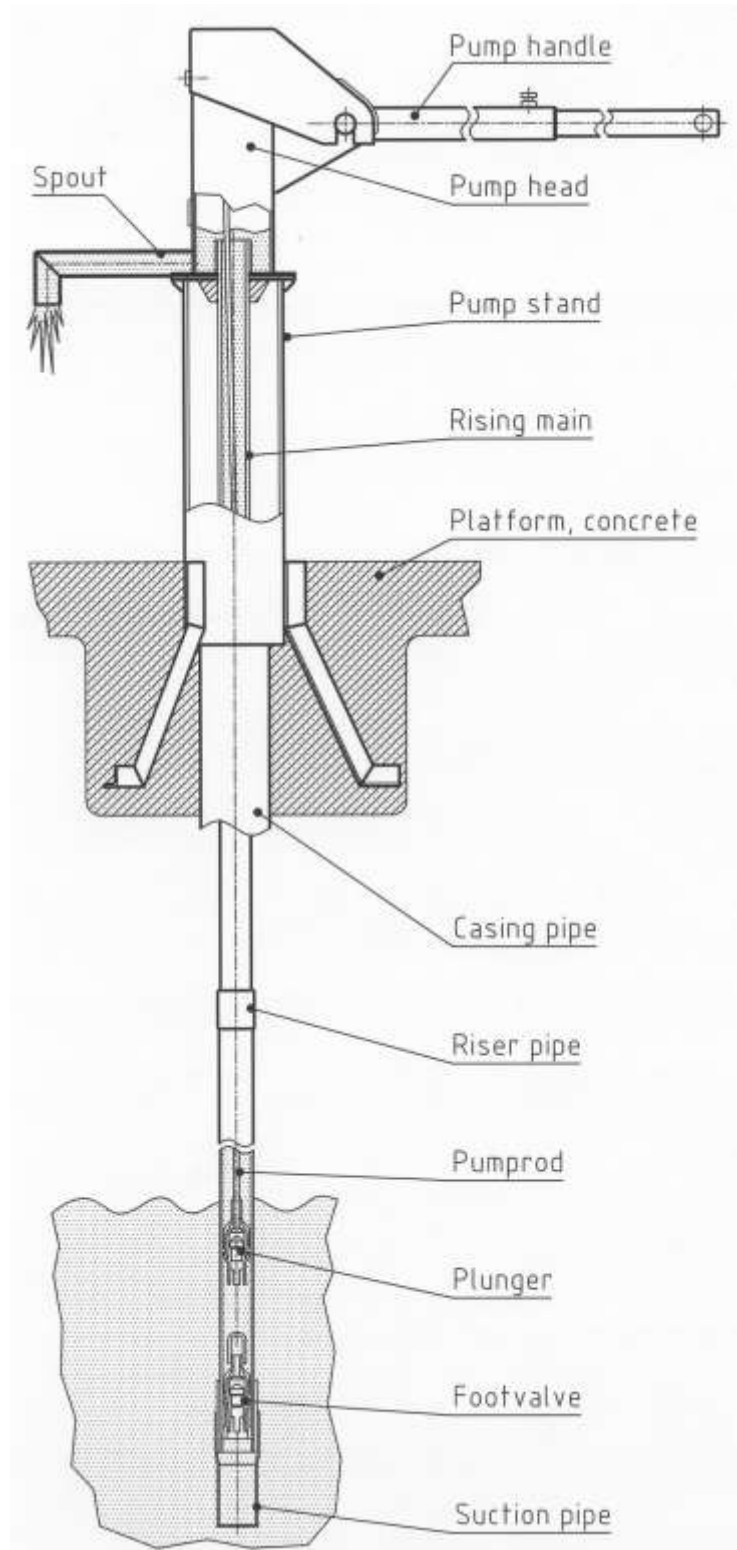

C1) Jibon Pump

Description

The JIBON Pump is a lever operated deep set pump. Typically, JIBON Pumps are installed in collapsible tube wells with the screen extending to the coarse sand aquifer.

Technical data

Cylinder diameter:	54.0 mm
Maximum Stroke:	215 mm
*) Approx. discharge,(75 watt input)	
at 5 m head:	3.0 m ³ /hour
at 10 m head:	1.8 m ³ /hour
at 15 m head:	1.2 m ³ /hour
Pumping lift	1 - 15 m
Population served:	50 - 100 people
Households:	5 - 10 households
Water consumption:	20 - 25 l/per capita
Type of well:	borehole or dugwell

Material

Pump head and handle are made of cast iron, pump rods are of FRP-material (fiber glass reinforced plastic), rising main and suction pipe and robo screen are of PVC pipe, plunger and footvalve are of PVC, stainless steel and rubber. This makes this pump reasonably corrosion resistant.

Local manufacturing

The JIBON Pump has an excellent potential for local manufacturing.

Installation

The installation of the JIBON Pump is easy and does not need any lifting equipment or special tools. The drillers who sink the tube wells with the "sludger method" are also installing the pumps.

Maintenance

This pump has an excellent "Community Management Potential". Only two spanners are needed to repair the plunger and the footvalve. All maintenance operations can be performed by a village caretaker.

Remarks

This pump is limited to pumping lifts of max. of 20 m. It is recommended not to go deeper than 15 m. The JIBON Pump is not designed for a high daily output, but rather a family or small community pump.

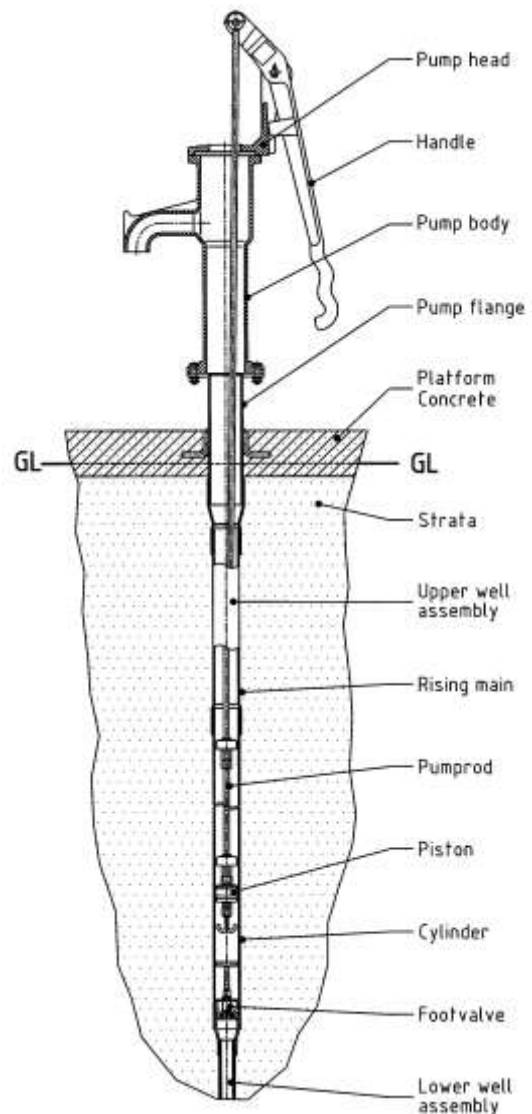

C2) Walimi Pump

Description

The WALIMI Pump is a conventional lever action handpump. The riser pipes are made of PVC-HI and are connected by threads. The bearings for the lever action are made of specially treated hardwood. Cylinders are available in 2" and 3" diameter.

Technical data

Cylinder diameter:	50.0 mm
Maximum Stroke:	170 mm
*) Approx. discharge,(75 watt input)	
at 5 m head:	2.0 m ³ /hour
at 10 m head:	1.3 m ³ /hour
at 15 m head:	1.0 m ³ /hour
Pumping lift	2 - 40 m
Population served:	- 300 people
Households:	30 households
Water consumption:	15 - 20 l/per capita
Type of well:	borehole or dugwell

Material

Pump head, handle and pump stand are made of galvanized steel, pumprods are of stainless steel, rising main and cylinders are of PVC-HI pipes and the "down hole components" are made of plastic, stainless steel and rubber components. This makes this pump reasonably corrosion resistant.

Local manufacturing

All steel parts of this pump have a potential for local manufacturing. Local companies who manufacture PVC-HI pipes and have the knowledge of machining engineering plastics are able to produce the "down hole components". The cost of the tooling requirement is substantial and therefore the number of manufacturer will be limited.

Installation

The installation of the WALIMI Pump is not difficult and does not need any lifting equipment.

Maintenance

This pump has an excellent "Community Management Potential", it is reliable, easy to repair by a village caretaker.

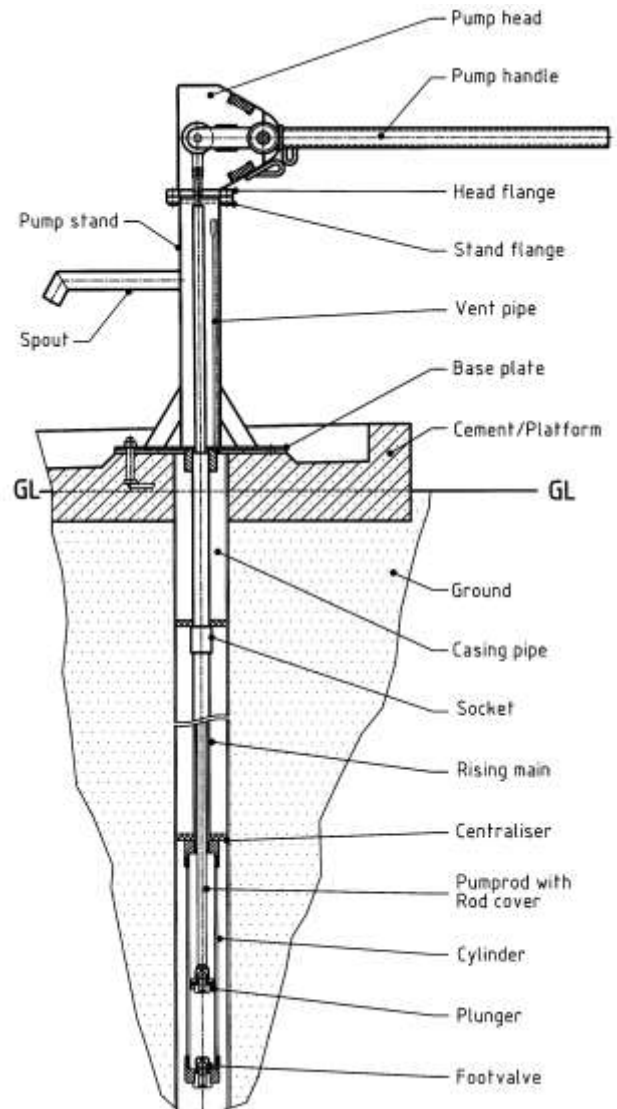

C3) India Mark II Pump

Description

The INDIA Mark II Pump is a conventional lever action handpump and is subject to Indian Standard IS 9301. The down hole components exist of a brass lined cast iron cylinder and the brass plunger has a double nitrile rubber cup seal. The rising main is of Ø32 mm GI pipe and the pumprods are of galvanized steel with threaded connectors.

Technical data

Cylinder diameter:	63.5 mm
Maximum Stroke:	125 mm
*) Approx. discharge,(75 watt input)	
at 10 m head:	1.8 m ³ /hour
at 15 m head:	1.3 m ³ /hour
at 20 m head:	1.0 m ³ /hour
at 25 m head:	0.9 m ³ /hour
at 30 m head:	0.8 m ³ /hour
Pumping lift	10 - 50 m
Population served:	- 300 people
Households:	30 households
Water consumption:	15 - 20 l/per capita
Type of well:	borehole or dugwell

Material

Pump head, handle, water tank, pump stand and pumprods are made of galvanized steel, rising main of galvanized GI pipe, pump cylinder cast iron / brass, plunger and footvalve of brass. This pump is not corrosion resistant and should not be used in areas with aggressive water (pH value < 6.5).

Local manufacturing

All "above ground components" have a potential for local manufacturing, all other parts need a high degree of quality control to ensure a reliable operation. The cost of the tooling requirement is substantial and therefore the number of manufacturer will be limited.

Installation

The installation of the INDIA Mark II Pump need well trained area mechanics or a mobile team with lifting tackle and comprehensive tool kit.

Maintenance

This pump has limited "Community Management Potential", but it is reliable and popular with the communities. To service the INDIA Mark II Pump skills and tools are needed which exceeds the ability of a village-level caretaker. However trained area mechanics can successfully maintain the pump.

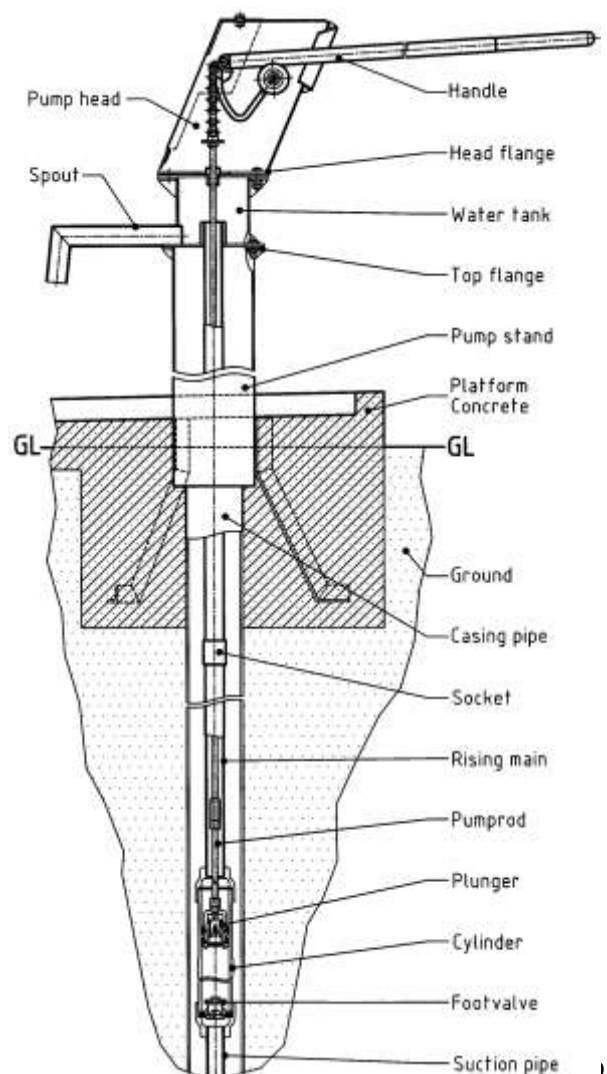

C4) India Mark III Pump

Description

The INDIA Mark III Pump is a conventional lever action handpump and is subject to Indian Standard IS 13056. This pump has similar configurations as the INDIA Mark II, only the “down hole components” were changed in order to improve the village level maintenance. The most important improvement is the “open top cylinder”, which makes it possible to remove the plunger and also the footvalve without lifting the cylinder and the rising main (Ø65 GI pipe).

Technical data

Cylinder diameter:	63.5 mm
Maximum Stroke:	125 mm
*) Approx. discharge,(75 watt input)	
at 10 m head:	1.8 m ³ /hour
at 15 m head:	1.3 m ³ /hour
at 20 m head:	1.0 m ³ /hour
at 25 m head:	0.9 m ³ /hour
at 30 m head:	0.8 m ³ /hour
Pumping lift	10 - 30 m
Population served:	- 300 people
Households:	30 households
Water consumption:	15 - 20 l/per capita
Type of well:	borehole or dugwell

Material

Pump head, handle, water tank, pump stand and pumprods are made of galvanized steel, rising main of galvanized GI pipe, pump cylinder cast iron / brass, plunger and footvalve of brass. This pump is not corrosion resistant and should not be used in areas with aggressive water (pH value < 6.5).

Local manufacturing

All “above ground components” have a potential for local manufacturing, the other parts need a high degree of quality control to ensure a reliable operation. The cost of the tooling requirement is substantial and therefore the number of manufacturer will be limited.

Installation

The installation of the INDIA Mark III Pump needs well-trained area mechanics or a mobile team with lifting tackle and comprehensive tool kit. Pump cylinder settings of more than 30 m are difficult, because of weight of the rising main.

Maintenance

This pump has an improved Community Management Potential” compared to the INDIA Mark II, because the “open top cylinder” gives the possibility of a simpler maintenance with less tools involved.

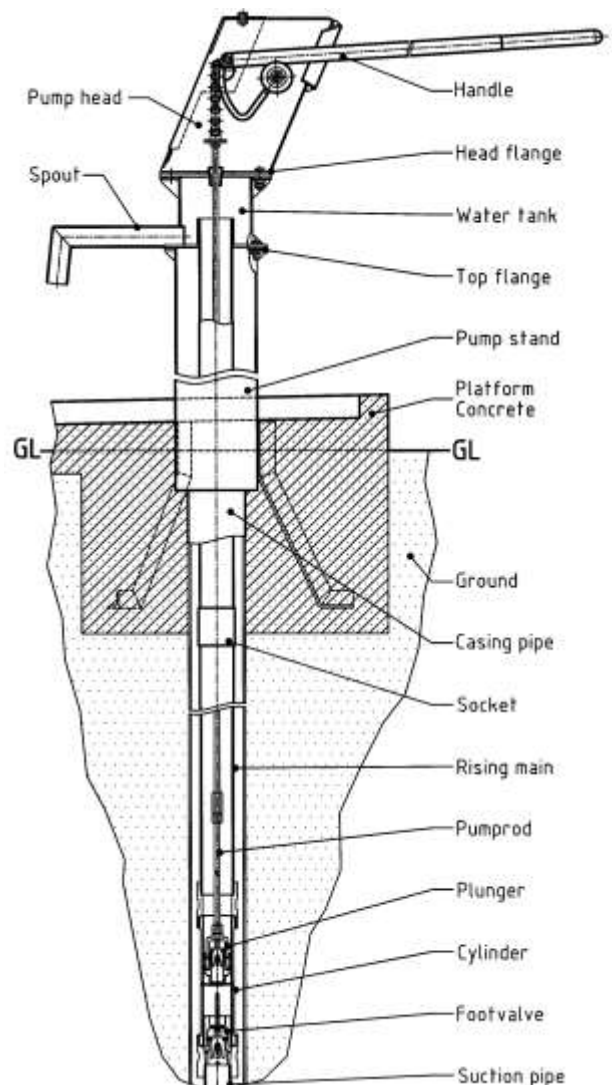

C5) U3M Pump

Description

The U3M pump is a conventional lever action handpump. The configuration includes an “open top” cylinder; the piston can be removed from the cylinder without dismantling the rising main. The footvalve is retractable with a fishing tool. The pump head has similar configurations as the INDIA Mark III Pump and the “down hole components” are similar to the Afridev components. The cylinder follows the Afridev Pump configuration. The plunger uses the 50 mm open top India MK III brass design.

Technical data

Cylinder diameter:	50.0 mm
Maximum Stroke:	125 mm
*) Approx. discharge,(75 watt input)	
at 10 m head:	1.2 m ³ /hour
at 15 m head:	1.0 m ³ /hour
at 20 m head:	0.8 m ³ /hour
at 30 m head:	0.6 m ³ /hour
Pumping lift	10 - 45 m
Population served:	- 300 people
Households:	30 households
Water consumption:	15 - 20 l/per capita
Type of well:	borehole or dugwell

Material

Pump head, handle, water tank, pump stand are made of galvanized steel, pumprods of stainless steel or of FRP rods (fiber glass reinforced plastic), rising main of PVC-U pipe (Ø63 mm), cylinder of PVC-U pipe with brass liner (Ø50 mm), plunger and footvalve are of brass or plastic. This pump is fully corrosion resistant.

Local manufacturing

All “above ground components” and steel parts of this pump have a potential for local manufacturing. The other parts need a high degree of quality control to ensure a reliable production. Local companies who manufacture PVC-U pipes are able to produce the rising main. The cost of the tooling requirement is substantial and therefore the number of manufacturer will be limited.

Installation

The installation of the U3M Pump is not difficult and does not need any lifting equipment.

Maintenance

This pump has an excellent “Community Management Potential”, it is reliable, easy to repair by a village caretaker and popular with the communities. Few tools are needed for all repairs.

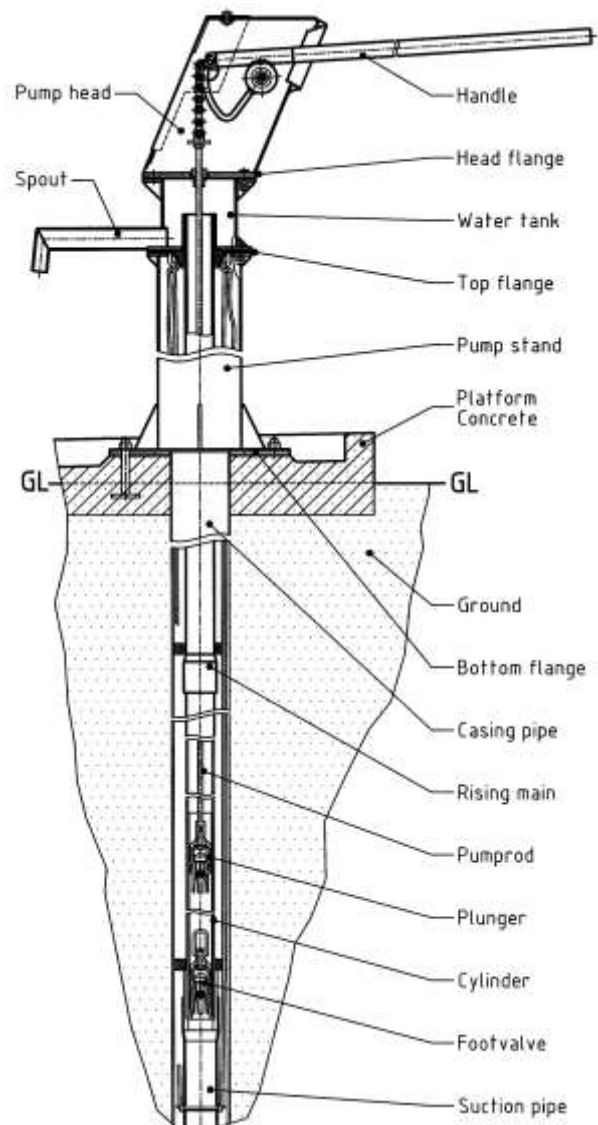

C6) Afridev Pump

Description

The AFRIDEV Pump is a conventional lever action handpump. The configuration includes an “open top” cylinder: the piston can be removed from the cylinder without dismantling the rising main. The footvalve is retractable with a fishing tool.

Technical data

Cylinder diameter:	50.0 mm
Maximum Stroke:	225 mm
*) Approx. discharge,(75 watt input)	
at 10 m head:	1.4 m ³ /hour
at 15 m head:	1.1 m ³ /hour
at 20 m head:	0.9 m ³ /hour
at 30 m head:	0.7 m ³ /hour
Pumping lift	10 - 45 m
Population served:	- 300 people
Households:	30 households
Water consumption:	15 - 20 l/per capita
Type of well:	borehole or dugwell

Material

Pump head, handle and pump stand are made of galvanized steel, pumprods of stainless steel or of FRP rods (fiber glass reinforced plastic), rising main of PVC-U pipe (Ø63 mm), cylinder of PVC-U pipe with brass liner (Ø50 mm), plunger and footvalve are of brass or plastic. This pump is fully corrosion resistant.

Local manufacturing

All steel parts of this pump have a potential for local manufacturing. Local companies who manufacture PVC-U pipes and have the knowledge of processing engineering plastics are able to produce the “down hole components”. The cost of the tooling requirement is substantial and therefore the number of manufacturer will be limited.

Installation

The installation of the AFRIDEV Pump is not difficult and does not need any lifting equipment.

Maintenance

This pump has an excellent “Community Management Potential”, it is reliable, easy to repair by a village caretaker and popular with the communities.

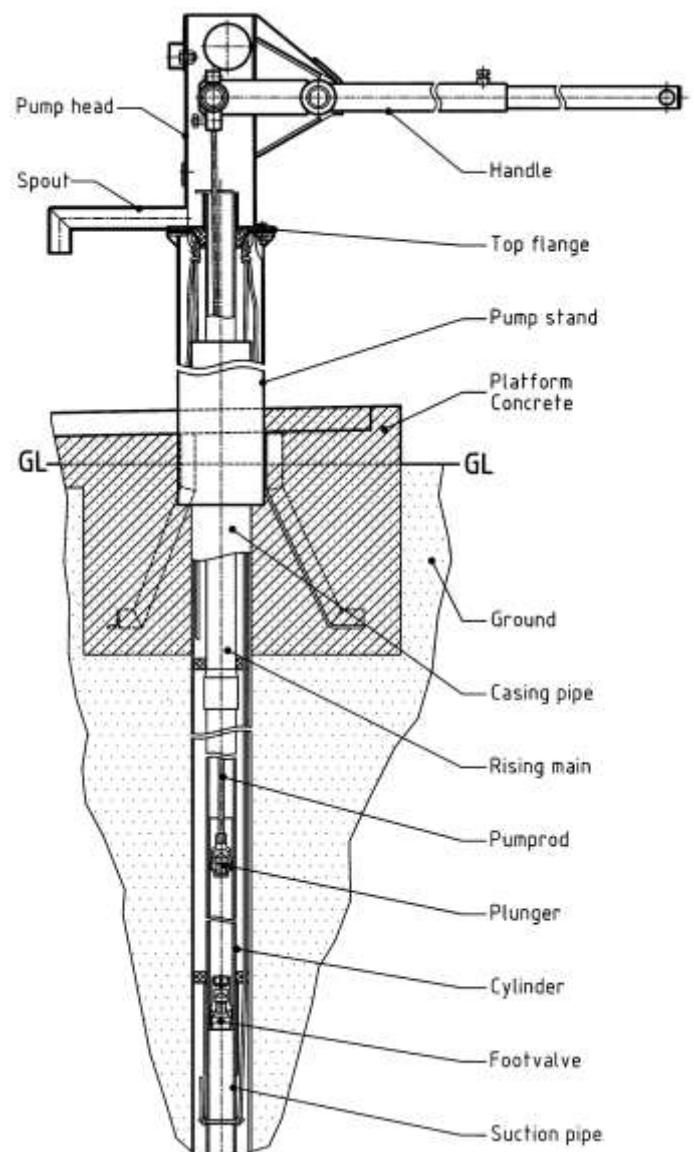

C7) BUSH Pump (not a property of “G-W”)

Description

The BUSH Pump is a conventional lever action handpump. The typical feature of this pump is the “Hardwood block” that acts as both, a bearing and lever mechanism. The pump is designed as such that the stand can be directly bolted to the protruding steel casing (\varnothing 150 mm Nominal Bore).

Technical data

Cylinder diameter:	75.0 mm
Maximum Stroke:	200 - 250 mm
*) Approx. discharge,(75 watt input)	
at 10 m head:	1.4 m ³ /hour
at 15 m head:	1.1 m ³ /hour
at 25 m head:	0.8 m ³ /hour
at 30 m head:	0.7 m ³ /hour
Pumping lift	5 - 80 m
Population served:	- 300 people
Households:	30 households
Water consumption:	15 - 20 l/per capita
Type of well:	borehole or dugwell

Material

Pump stand made of mild steel painted, handle and riser pipes of galvanized GI pipe, pumprods are of galvanized steel, cylinder of brass, bearing block of hardwood, plunger and footvalve of bronze or brass. This pump is not corrosion resistant and should not be used in areas with aggressive water (pH value < 6.5).

Local manufacturing

The Bush Pump has an excellent potential for local manufacturing and is produced by different companies in Zimbabwe.

Installation

The installation of the Bush Pump needs well trained area mechanics. Lifting tackle is only used for deep applications and for large size “open top cylinders”. No special tools are needed.

Maintenance

The pump with the standard configuration has a limited “Community Management Potential”, but it is very reliable and popular with the community. The “open top cylinder version” gives the possibility of a simpler maintenance (see remarks).

Remarks

Besides the “Standard” configuration, there exists an “Open Top Cylinder” version with different cylinder sizes (\varnothing 50 mm, \varnothing 63.5 mm and \varnothing 75 mm). To make maintenance easy, pump rods with casehardened hook and eye connectors are also available.

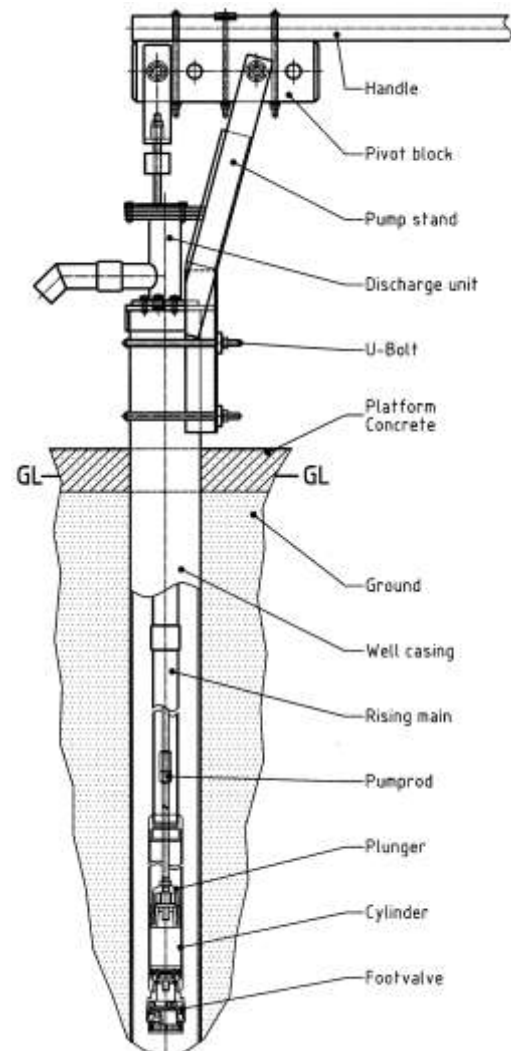
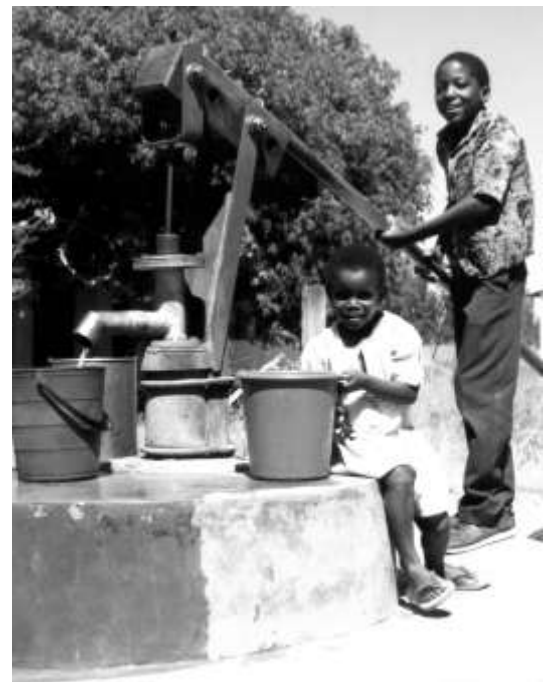

C8) VOLANTA Pump

Description

The VOLANTA Pump is a reciprocating pump driven by a large flywheel. A crank and a connecting rod convert the rotary motion into a reciprocating action, which is transmitted to the plunger via stainless steel pumprods. The crankshaft and the flywheel run on ball bearings mounted on a plate that can be fixed to a steel or concrete pedestal. The cylinder is of glass fiber reinforced plastic with a close-fitting seal-less stainless steel plunger. The complete cylinder can be lifted from the well by the threaded pumprods, without removing the PVC-U rising main.

Technical data

Cylinder diameter:	50.0 mm
Maximum Stroke:	400 mm
*) Approx. discharge, (75 watt input)	
at 20 m head:	1.0 m ³ /hour
at 40 m head:	0.5 m ³ /hour
at 60 m head:	0.3 m ³ /hour
at 80 m head:	0.2 m ³ /hour
Pumping lift	10 - 80 m
Population served:	- 300 people
Households:	30 households
Water consumption:	15 - 20 l/per capita
Type of well:	borehole

Material

Pump stand / flywheel are made of mild steel painted, rising main of PVC-U pipes, cylinder of reinforced epoxy resin, plunger and pumprods of stainless steel, valves of rubber. This pump is corrosion resistant.

Local manufacturing

The VOLANTA Pump is a protected product and is not intended for local manufacturing, but there are few countries where assembling and installation are made locally.

Installation

The installation of the VOLANTA Pump is not difficult and does not need any lifting equipment. However extensive masonry work is required.

Maintenance

This pump has a good "Community Management Potential". Simple tools are needed to pull out the pumping element, including pump rod and footvalve.

Remarks

Some users find it difficult to start the pump. Small children have to stay away from this pump, because the area of the rotating flywheel can be a dangerous playground.

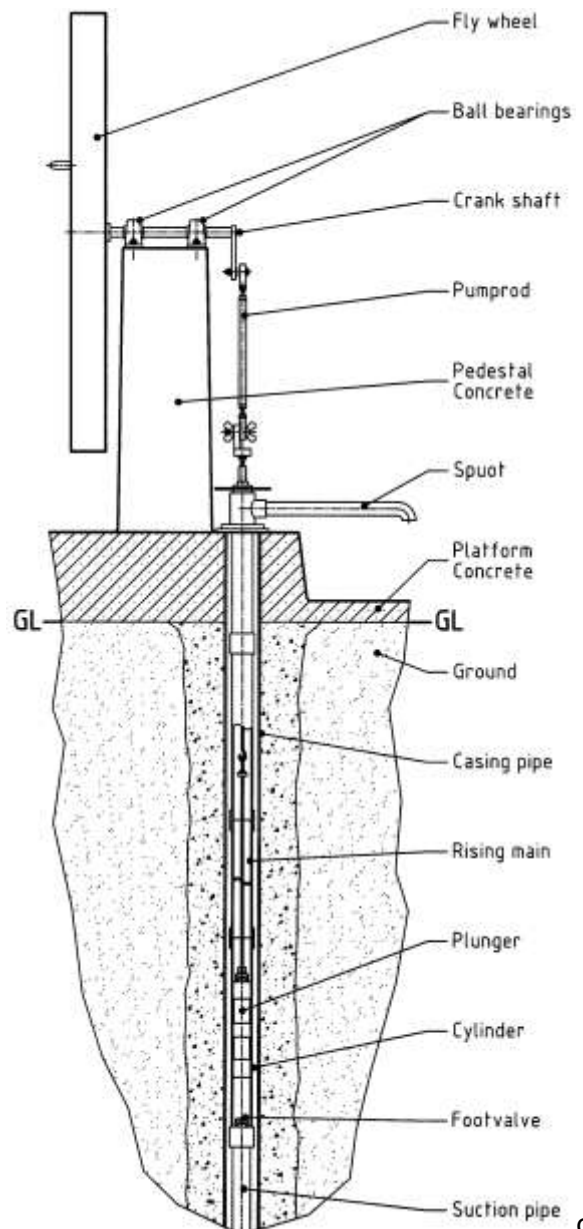

Rotary Hand Pumps

A) Rope Pumps

This pump type works with a loop of rope, which is pulled through a plastic riser pipe. Regularly spaced washers are fixed on the rope (approx. 1 m spacing), which are guided into the riser pipe at the bottom of the well and are carrying water to the spout. At the pump stand, the rope is moved by a rubber lined pulley, mostly made of cuttings from worn car tires. The pulley is operated with a crank handle in a steady speed, so that sufficient water is flowing from the spout.

Because of the required clearance between the washers and the riser pipe, the movement of the rope needs a certain speed, so that the velocity of the drawn water is continuous.

As soon as the operation stops, the water in the rising main will drain slowly.

This type of pump is usually placed on a dug-well and it's mostly used as family pump. However, there are different models existing that are suitable for larger communities and also to be installed on boreholes.

The rope and washer pump has the advantage of a simple design and fairly easy maintenance.

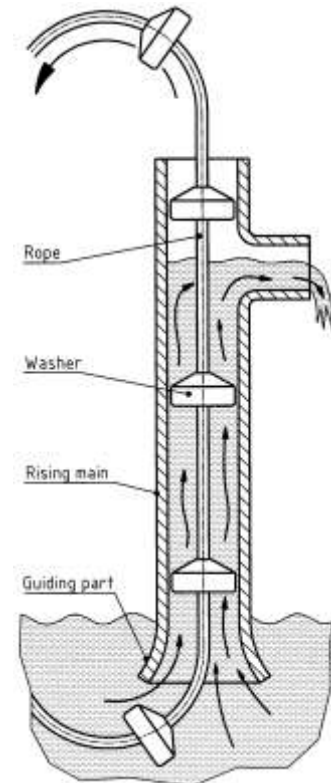

A1) Nicaragua Rope Pump

Description

The Rope Pump features a unique design in which small plastic pistons are lined up on a rope. The distance between the pistons is approximately 1 m. Over a crank operated drive wheel the rope is pulled through a plastic rising pipe. The drive wheel consists of cut old tires. A ceramic guide box leads the rope with the pistons into the rising pipe.

Technical data

Piston nominal diameter:	1", ¾", ½"
*) Approx. discharge,(75 watt input)	
at 10 m head:	1.4 m ³ /hour
at 15 m head:	1.1 m ³ /hour
at 20 m head:	0.7 m ³ /hour
Pumping lift:	0 - 30 m
Population served:	- 70 people
Households:	3 - 10 households
Water consumption:	15 - 20 l/per capita
Type of well:	dugwell or borehole

Material

Pump stand made of painted steel rods, crank made of painted steel pipe, cover of galvanized and painted plate, drive pulley of rubber and mild steel, pistons of plastic, guide box of ceramic, concrete and PVC, rising main of PVC pipe. The Nicaragua Rope Pump is reasonably corrosion resistant.

Local manufacturing

The Rope Pump has an excellent potential for local manufacturing.

Installation

The installation of the Rope Pump is easy. It can be done by trained area mechanics. No lifting tackle and no special tools are needed.

Maintenance

The rope pump has an excellent "Community Management Potential". Torn or broken ropes can be replaced without any special tools. A village caretaker can perform all maintenance operations.

Remarks

This rope pump is usually installed in dug wells. Even though it is not limited in pumping lifts, the major application range is up 15 m. The Rope pump is not designed for a high daily output, but rather a family or small community pump. Models exist for family use as well as for community use.

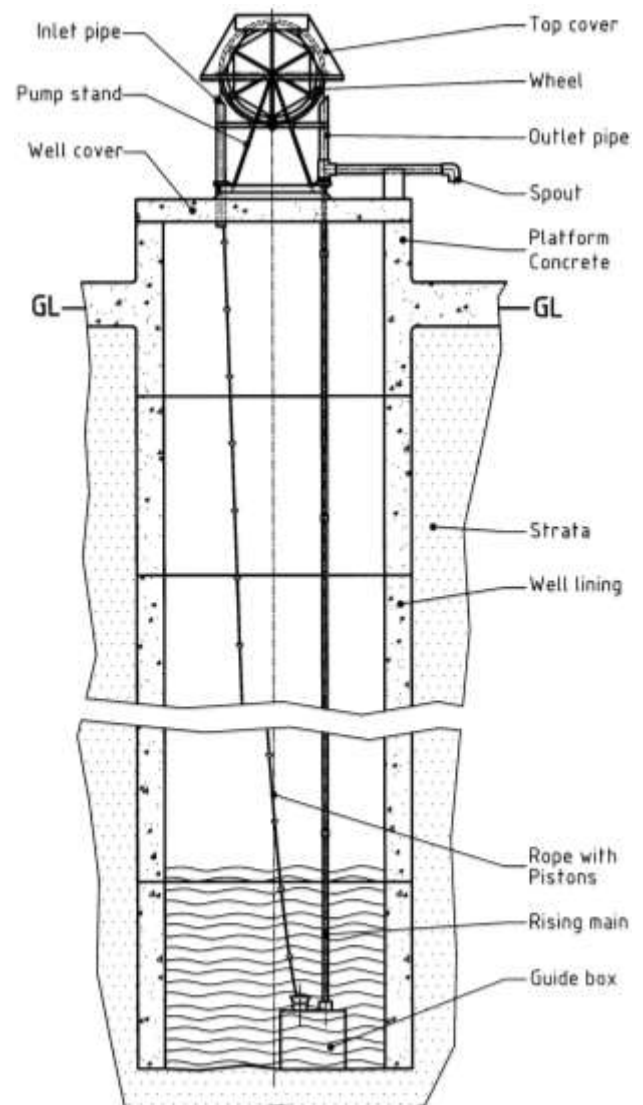

A2) Madagascar Rope Pump

Description

The Rope Pump features a unique design in which small plastic pistons are lined up on a rope. The distance between the pistons is approximately 1 m. Over a crank operated drive wheel the rope is pulled through a plastic rising pipe. The drive wheel consists of cut old tires. A concrete guide box with a glass bottle leads the rope with the pistons into the rising main.

Technical data

Piston nominal diameter:	1", ¾", ½"
*) Approx. discharge, (75 watt input)	
at 10 m head:	1.4 m ³ /hour
at 15 m head:	1.1 m ³ /hour
at 20 m head:	0.7 m ³ /hour
Pumping lift:	0 - 30 m
Population served:	- 70 people
Households:	3 - 10 households
Water consumption:	15 - 20 l/per capita
Type of well:	dugwell or borehole

Material

Pump stand and crank made of painted steel pipe, cover of galvanized and painted plate, drive pulley of rubber and mild steel, pistons of plastic, guide box of concrete, PVC and glass, rising main of PVC pipe. The Madagascar Rope Pump is reasonably corrosion resistant.

Local manufacturing

The Rope Pump has an excellent potential for local manufacturing.

Installation

The installation of the Rope Pump is easy. It can be done by trained area mechanics. No lifting tackle and no special tools are needed.

Maintenance

The rope pump has an excellent "Community Management Potential". Torn or broken ropes can be replaced without any special tools. A village caretaker can perform all maintenance operations.

Remarks

This rope pump is usually installed in dug wells. Even though it is not limited in pumping lifts, the major application range is up to 15 m. The Rope pump is not designed for a high daily output, but rather a family or small community pump.

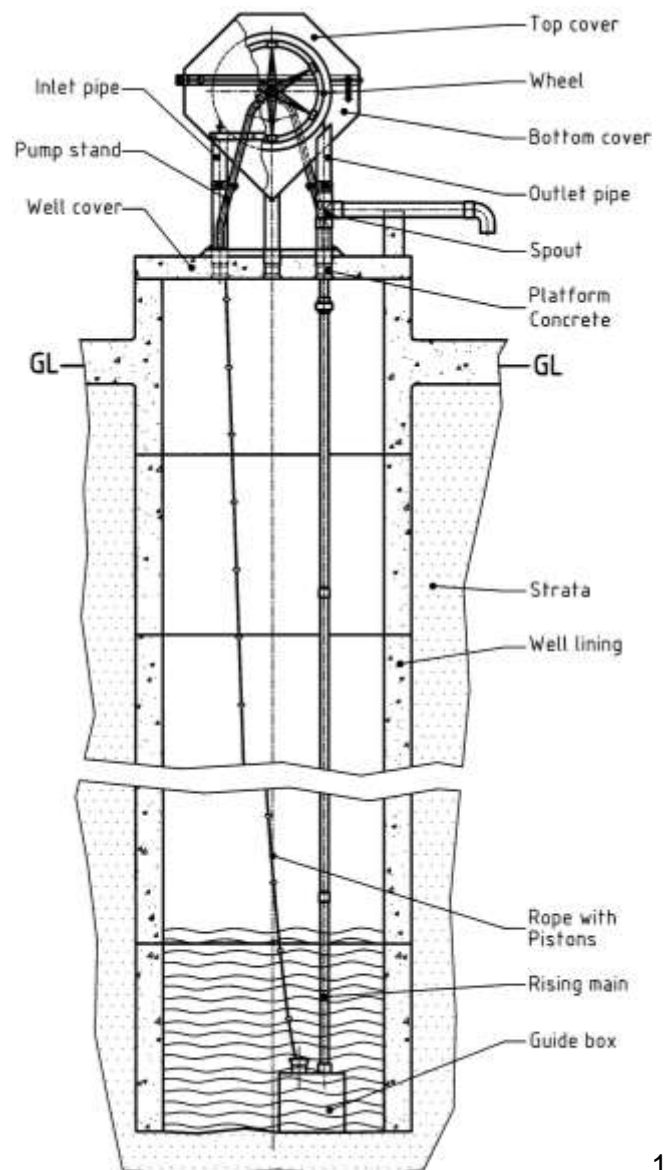

Displacement Hand Pumps

A) Diaphragm Pumps

An alternative to the use of a piston is to create a pump in which a flexible diaphragm is moved up and down thus displacing water.

The advantages of diaphragm pumps are that they are easy to install, since no heavy mechanical parts are used. They can also be made corrosion resistant through use of plastic hoses instead of rising mains.

The disadvantages are that they need high quality rubber diaphragms that are costly, and they have a relatively low efficiency because of the deformation work needed to expand the diaphragm.

Further, the working principle is relatively complicated and not so easy to understand. Thus, training of mechanics and caretakers is essential.

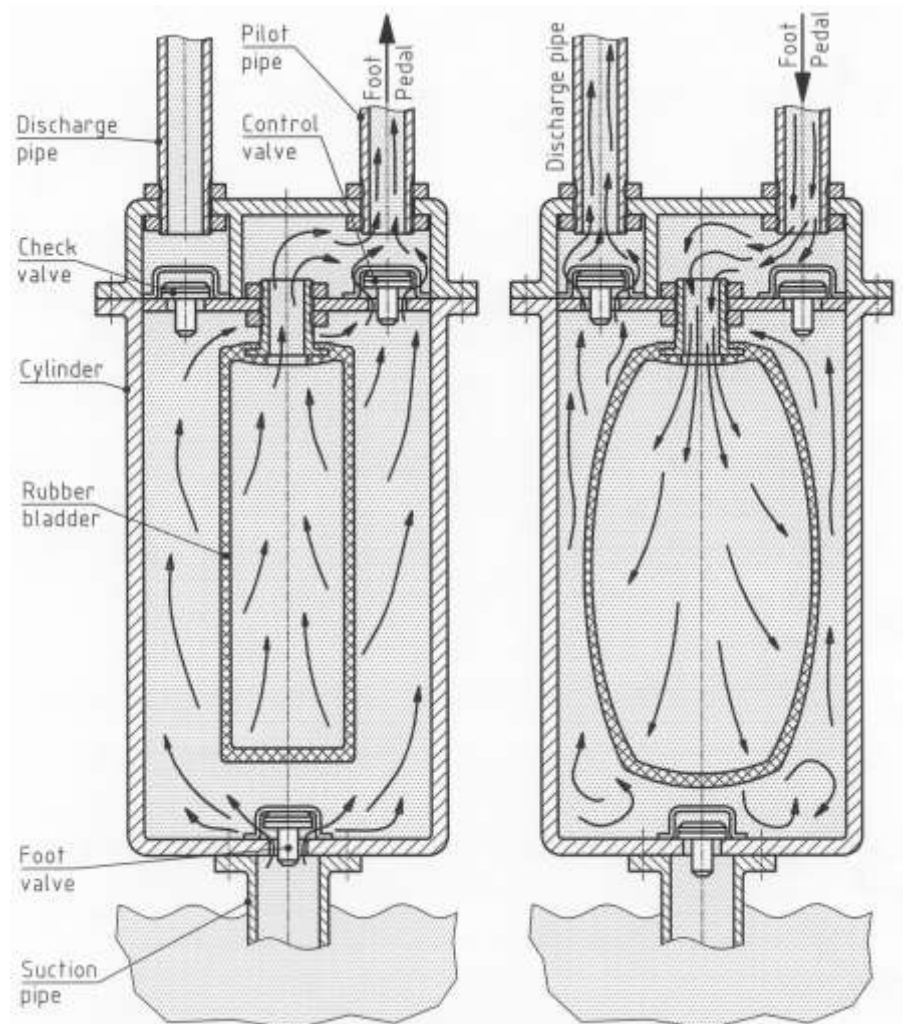

A1) Vergnet HYDROPUMP 60

Description

The HYDROPUMP 60 Pump has unconventional design features. It is operated by foot with a pedal. The displacement of the piston located at ground level is hydraulically transmitted to a rubber diaphragm down in a stainless steel cylinder. The expansion and the contraction of the diaphragm deliver the water to the surface. The top cylinder is connected to the pumping element on the bottom, via a flexible hose.

Technical data

Cylinder diameter:	not applicable
Maximum Stroke:	200 mm
*) Approx. discharge, (75 watt input)	
at 10 m head:	1.0 m ³ /hour
at 15 m head:	0.9 m ³ /hour
at 20 m head:	0.75 m ³ /hour
at 30 m head:	0.65 m ³ /hour
Pumping lift	10 - 45 m
Population served:	- 300 people
Households:	30 households
Water consumption:	15 - 20 l/per capita
Type of well:	borehole

Material

Pump stand made of galvanized steel painted, foot pedal of mild steel, pipes of flexible LDPE hose, top and bottom cylinder of stainless steel, pumping element of a rubber diaphragm and valves of brass. This pump is corrosion resistant.

Local manufacturing

The HYDROPUMP 60 is a protected product and is not intended for local manufacturing. Only the steel parts of the pump stand would have a potential for local manufacturing.

Installation

The installation of the HYDROPUMP 60 is very simple and does not need any lifting equipment.

Maintenance

This pump has a good "Community Management Potential". The above ground components allow interventions by the village caretaker, but below ground components are difficult to repair. The diaphragm requires frequent cleaning.

Remarks

The replacement of a diaphragm is expensive. The pump requires a considerable effort to operate. Although full body weight can be applied to the pedal, children and small users find it sometimes hard to operate the pump. If the yield of the borehole allows and the water demand is high, 2 pumps in one borehole can be installed.

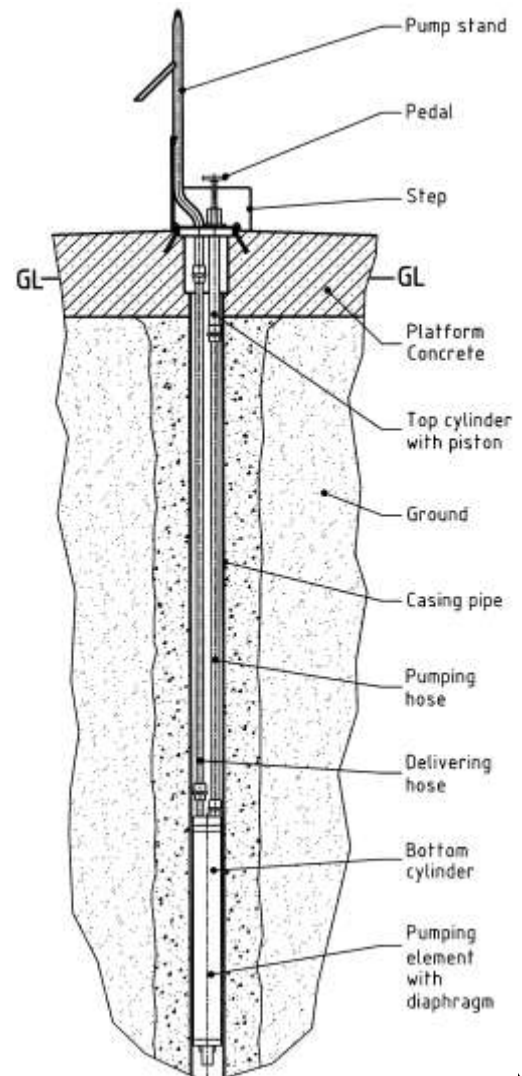

A2) Progressive Cavity Pumps (mono)

Contrary to most rotary positive displacement pumps, progressive cavity pumps can be used in small diameter boreholes.

The pump consists of a single helix rotor inserted into a double helix stator. The rotor helix is made to a high finish; i.e. chromium plated steel or polished stainless steel (SS). It is circular in cross section so that it fits exactly into one of the two helices of the stator. As a result, the empty second helix of the stator is divided into a number of separated voids. When the rotor is turned, these voids are screwed along the axis of rotation. In the well water will be trapped in the voids and when the rotor is rotated these volumes are pushed upwards and discharged into the rising main. Progressive cavity pumps need to be driven at a relatively high speed; therefore, handpumps are often fitted with a gearbox. This makes this type of pump relatively complicated and costly.

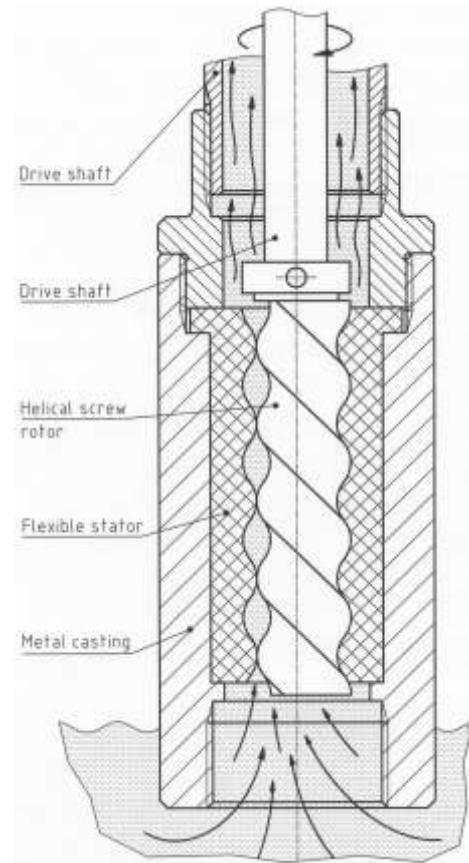

Technology Selection

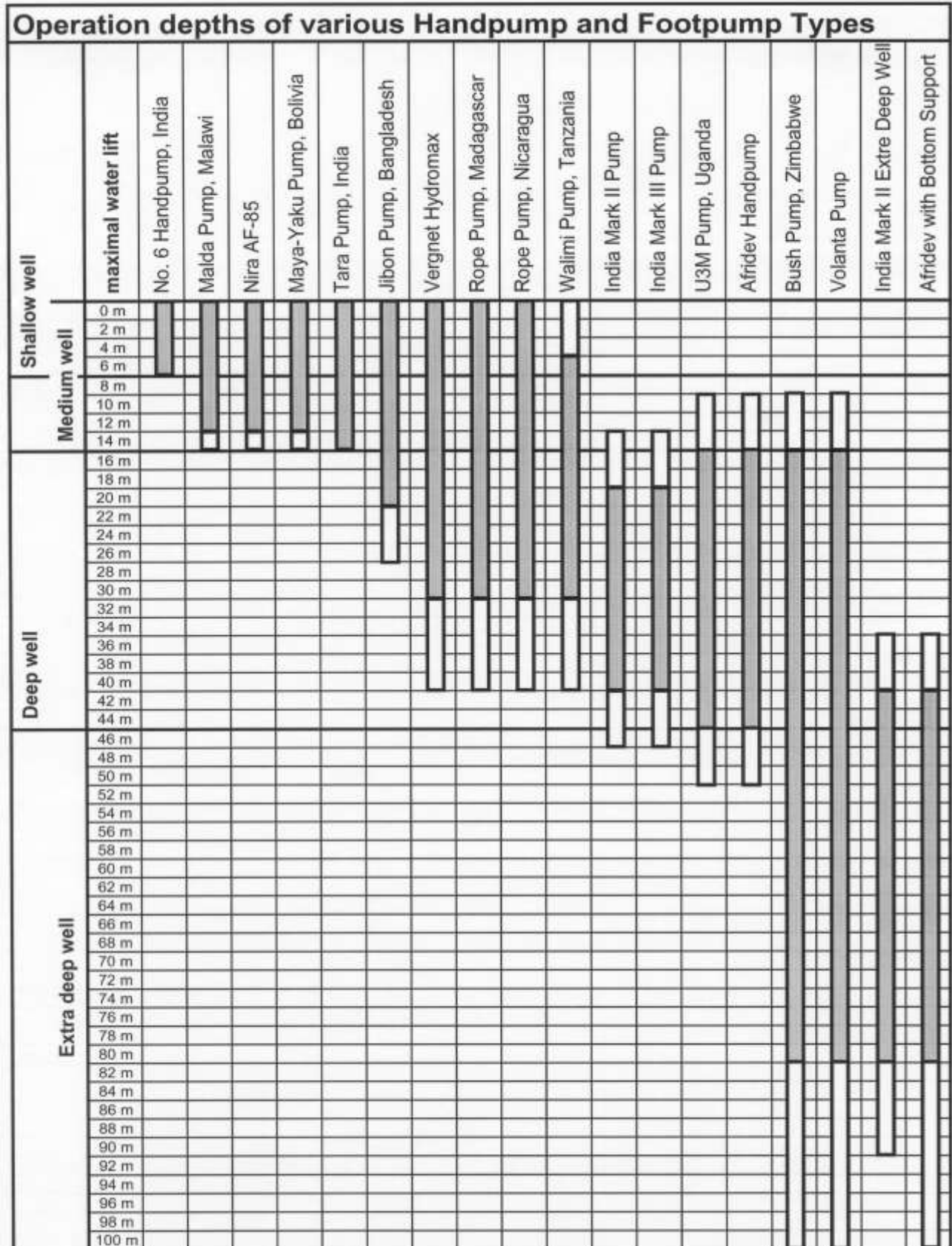

Motorized Pumps (for Boreholes)

There are three main types of motorized pumps that are suitable to be installed in boreholes:

- Submersible Pumps
- Line Shaft Pumps
- Jet Pumps

Besides the standard sources for the three pump types mentioned above (electric, diesel or petrol motors), there are also other power sources possible.

- Solar powered Pumps
- Wind powered Pumps

Submersible Pumps (for Boreholes)

A Submersible Pump is designed as such that it can be introduced into the well casing and lowered to the bottom of the well.

It is driven by an electric motor, which is directly attached to the pumping element and therefore totally submerged. This pump type is mainly used where electric power is available or ideally in combination with a Solar Pumping System.

The main parts of a submersible pump are:

- a) Electric motor hermetically enclosed in a stainless steel sleeve,
- b) Pump body with multiple impellers, footvalve and strainer,
- c) Rising main of GI or stainless steel pipes connected with sockets or PVC-HI hose. If a hose is used, the motor with connected pump body has to be hung from the top of the well by a stainless steel cable,
- d) Electrical cable for connecting the motor to the starting panel (power source),
- e) Starting panel,

Various sizes of submersible pumps are available, which can be installed in casings of Ø4", 6", 8", 10" and 12".

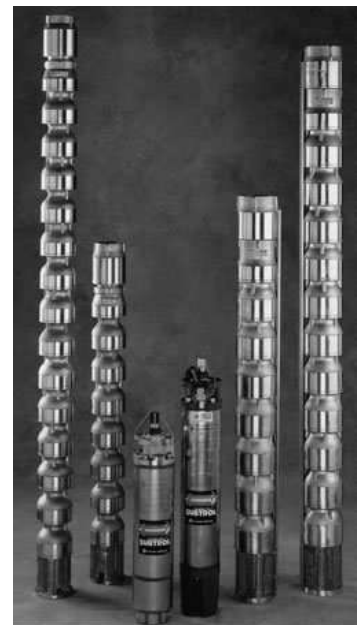
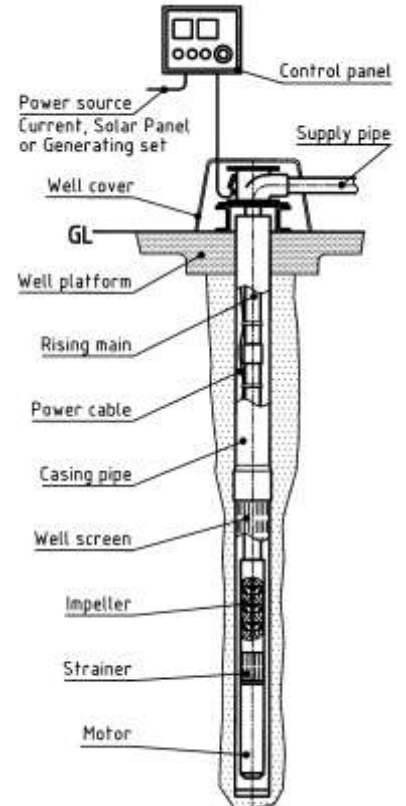

Line Shaft Pumps

The **Line Shaft Pump** has the driving element (motor) above ground, only the pumping element is introduced into the well casing.

A "Line Shaft" is used to connect the motor attached with the pumping element at the bottom of the well. The revolution of the motor is directly applied to the pumping element by the line shaft. Various motor types can be used to drive the pumping element (diesel engine, petrol engine, electric motor etc.). Line shaft pumps can be combined with various driving equipments:

Electrical motors

- can be placed directly on top of the drive head or
- attached at the side and connected with a V-belt.
- connected directly with a right angle gear, placed on top of the drive head.

Diesel or Petrol engines

- can be placed next to the drive head and connected with a V-belt or
- connected directly with a right angle gear, placed on top of the drive head.

In some cases, the vertical drive shaft of a wind mill can directly be connected with the line shaft of the pump.

The pumping element can vary too, but mostly used are:

- Vertical turbine** as used for the submersible pumps,
- Positive displacement unit.**

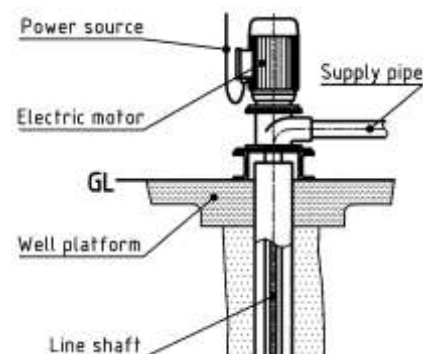
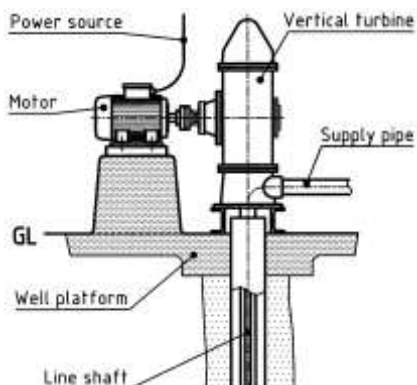
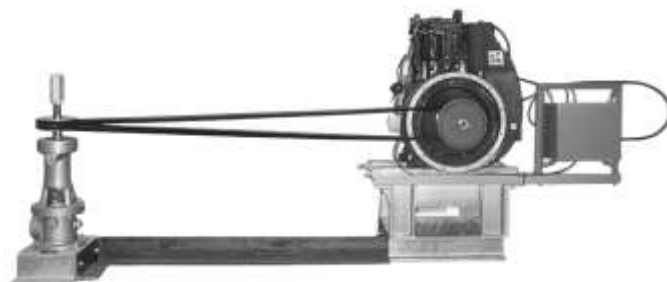
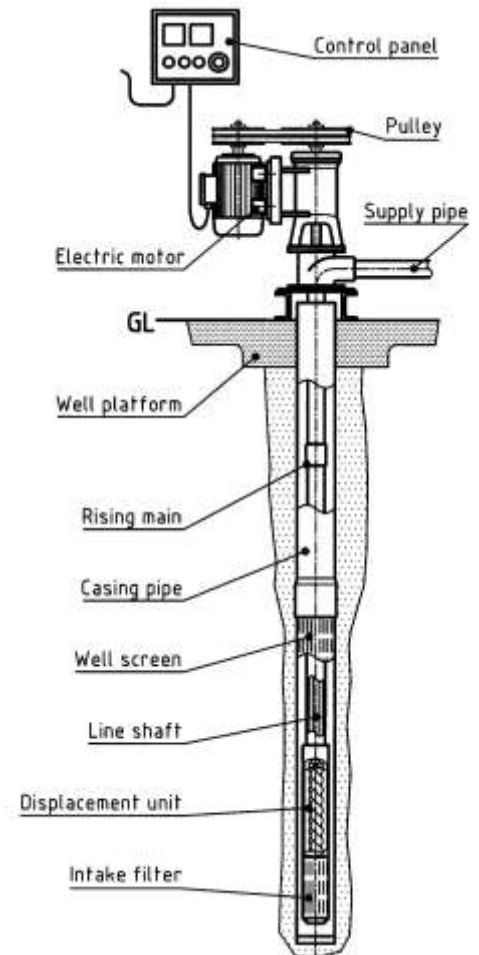

Jet Pumps

A Jet Pump is a type of an impeller-diffuser pump. About half of the drawn water is split in the diffuser and sent back to the well with high pressure through the pressure pipe. At the end of the pressure pipe the water is accelerated through the cone shaped nozzle and guided through the mixing chamber with high speed (Venturi principle). The pinched section of the mixing chamber is causing a pressure drop, which sucks in more water from the ejector body and intake. The water goes up the return pipe and through the impeller into the diffuser, where one part is sent back to the jet nozzle and the other part is directed into the delivery pipe.

Jet Pumps are relatively inefficient but can tolerate a wide range of operating conditions, including easily handling sand-laden or abrasive fluids.

This pump type does not have many working parts and therefore is easy to operate and it requires hardly any maintenance.

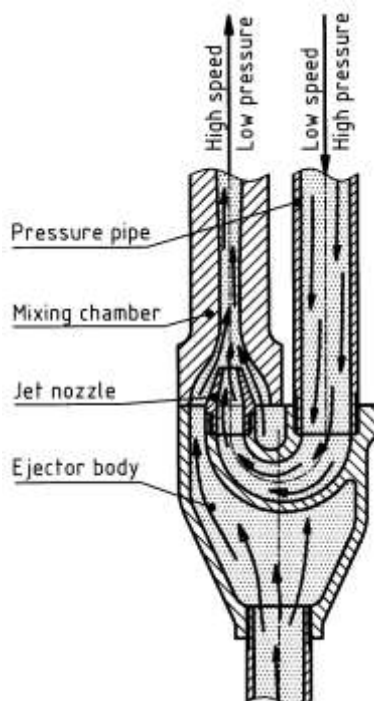
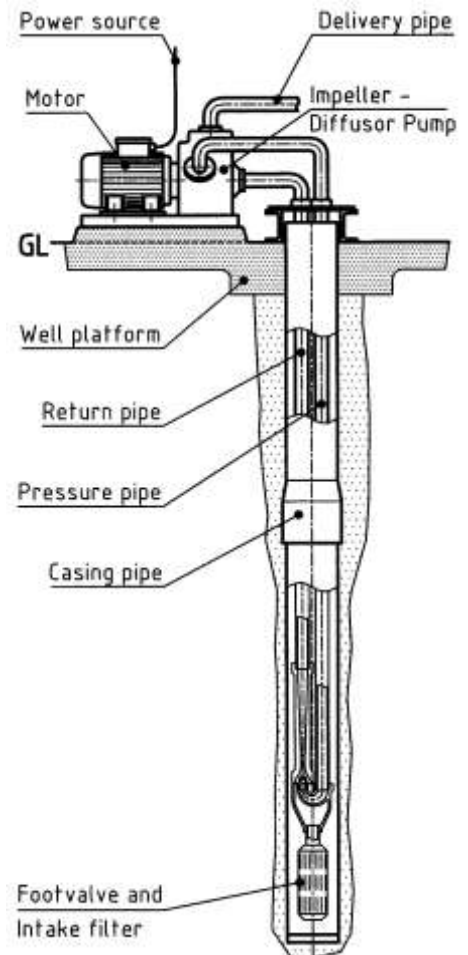

Solar Powered Pumps

The Photovoltaic Array which is assembled of a number of Solar Panels. These panels are converting sunlight into DC (direct current) electricity to charge the battery.

This DC electricity is fed to the battery via a solar regulator which ensures the battery is charged properly and does not get damaged.

DC appliances like a submersible pumps fitted with a DC motor can be fed directly from the battery.

AC (alternating current) appliances like a centrifugal pump require an inverter to convert the DC electricity into 240 Volt AC power.

A water storage tank is required to ensure water supply during the time when the pump is not running and to balance the daily (or weekly) fluctuation in demand.

In this case, a distribution network (piped system with stand posts) might be installed.

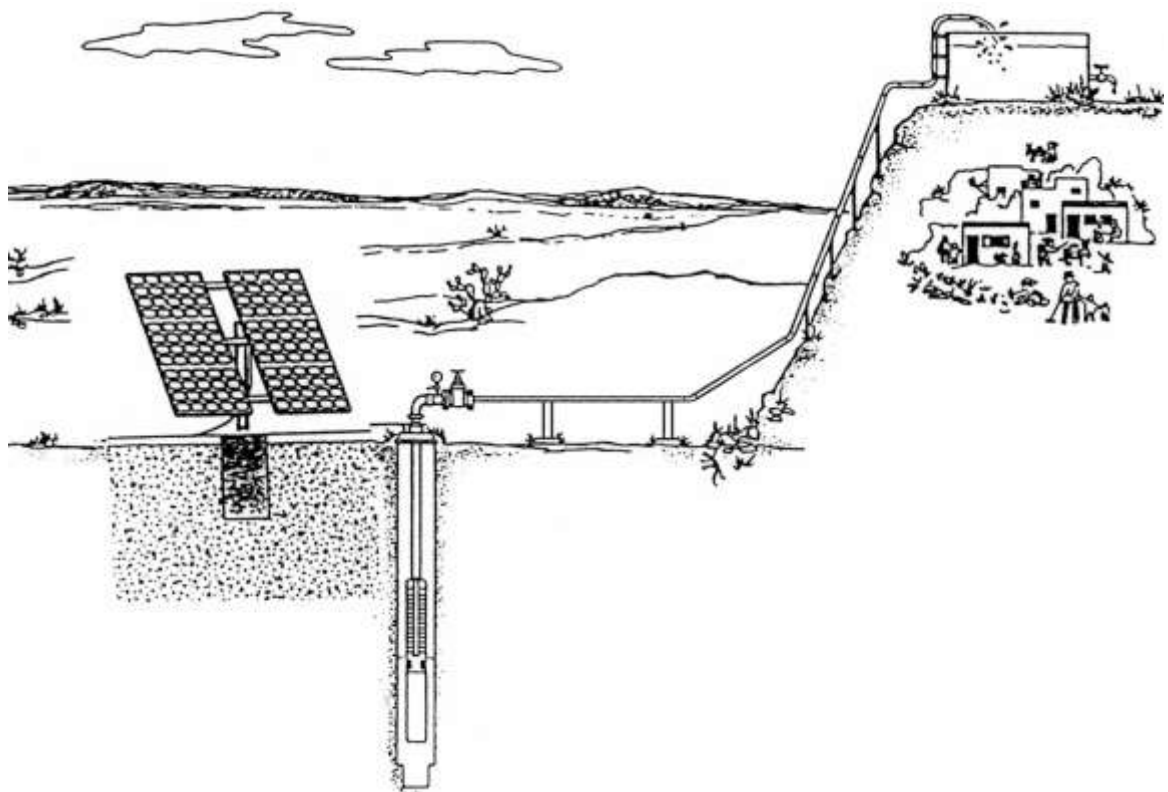
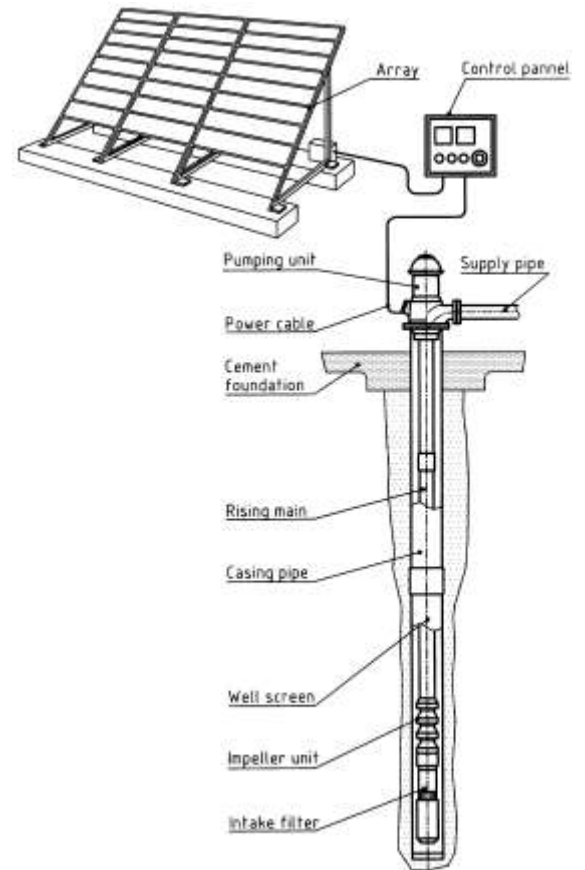



Solar panels

Solar panels on an array can be wired in series or in parallel to increase voltage or current respectively. The rated terminal voltage of a standard solar panel is usually around 17 Volt, but through the use of a regulator, this voltage is reduced to around 13 to 14 Volt as required for battery charging.



Solar Regulators

The purpose of a solar regulator (charge controller) is to regulate the current from the solar panels to prevent the battery from overcharging. A solar regulator also prevents the battery from backfeeding into the solar panel at night and, hence, flattening the battery.



Inverter

An inverter is a device which converts the DC power in a battery to 240 Volt AC electricity. Modified Sine Wave Inverters are relatively cheap, but not all applications are running smoothly (motors, fans, amplifiers, fluorescent lights) and laser printers can get damaged. Sine Wave Inverters are relatively expensive, but are providing AC power almost identical to the power from the grid.



Solar Batteries

Deep cycle batteries that are used in solar power systems are designed to be discharged over a long period of time (e.g. 100h) and recharged hundreds or thousands of times, unlike a conventional car battery, which is designed to, provide a large amount of current for a short amount of time.

Please note:

Since photovoltaic systems are "High-Tech Equipment", it is highly recommended that an experienced solar power specialist is consulted prior to any procurement.

Wind Powered Pumps

Wind power has been used for many years to pump water.

In the past, most wind turbines were directly mechanically coupled to the water pump. Most of these wind pumps for water pumping have a multi-bladed rotor on a horizontal axis, that must be oriented for facing the wind to extract power.

The horizontal rotation is reduced and changed into vertical rotation by a gear box, which drives a line shaft that is directly connected to a displacement unit at the bottom of the borehole.

The rotation of the rotor can also be transformed to a reciprocating movement, which can be connected to a piston located in the pump cylinder at the bottom of the borehole or well.

In recent years, wind turbines with a 2 or 3-bladed propeller were developed that convert wind energy to electrical energy, which in turn drives an electric motor.

The advantage of this system is that the wind turbine can be located in the best site for wind and the pump can be placed at the borehole or the well. Wind turbines for water pumping consist of a wind turbine, a permanent magnet synchronous generator, an induction motor and a centrifugal water pump (or a displacement pump).

Wind driven pumps for water pumping are often applied at high heads, typically 10 to 100 meters.

A large water storage tank is required to ensure water supply during times when the pump is not running due to little winds.

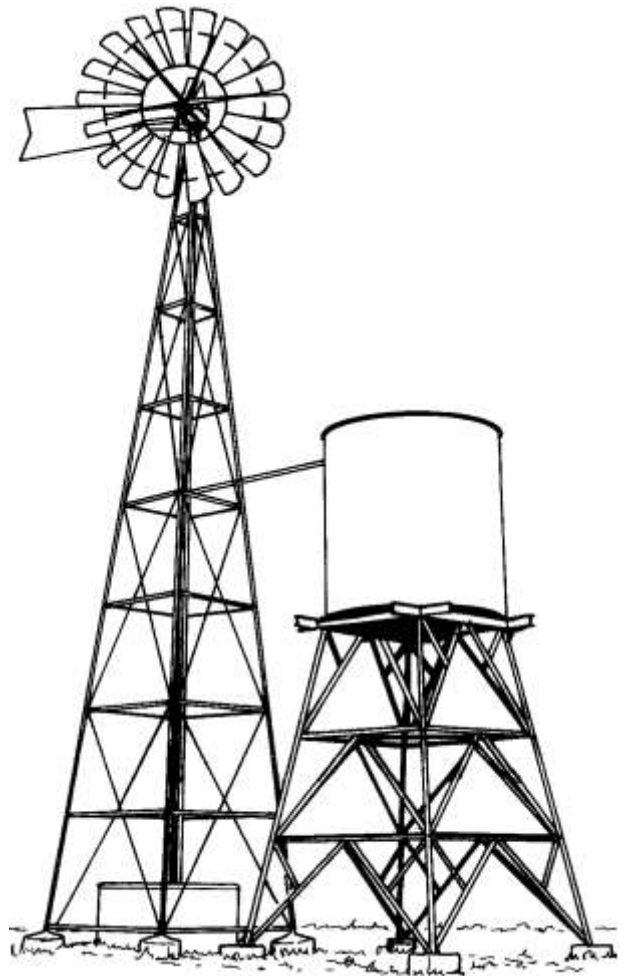

Rising Mains

The pipes used for transporting water from the pumping element to the surface are called “Rising Main Pipes”. Rising mains (Riser pipes) can be made of various materials:

- 4.1.6.1 GI pipes, Mild Steel, hot dip galvanized, connected with threaded sockets,
- 4.1.6.2 Stainless Steel pipes with threaded connections,
- 4.1.6.3 Plastic pipes, solvent cemented or threaded connections.

GI Pipes

Rising mains made of GI Pipes have the advantage of being long lasting in non-corrosive waters. Connecting of threaded riser pipes with sockets is done with two pipe wrenches and can easily be done by the community themselves. However, for deep applications, lifting tackle is required to hold the load of the connected riser pipes during installation and retrieval of the cylinder for maintenance and repair.

For sealing the conical pipe threads, “Teflon” tape, a special sealing grease or hemp fibres with grease is essential.

GI Pipes can be used in non-corrosive waters with a pH value greater than 6.5.

GI Pipes that are used for rising mains are available in $\text{Ø } 1 \frac{1}{4}$ ” (32 mm), $\text{Ø } 1 \frac{1}{2}$ ” (40 mm), $\text{Ø } 2$ ” (50 mm), $\text{Ø } 2 \frac{1}{2}$ ” (63.5 mm) and in lengths of 3 m.



Note:

If GI riser pipes are used for pumps with “Open Top Cylinders”, the sharp corners of the welding seam at the inside of the pipes should be eliminated by a “Scarfing Tool”, to avoid damaging of the plunger seal during installation and withdrawal of the plunger.

Stainless Steel Pipes

Rising main pipes are mostly used in places with corrosive waters. Due to the high material price, stainless steel pipes are usually thin-walled and therefore special care is required during handling and installation.

For threaded joints, a special sealing grease should be used, to avoid seizing of threads.

Note: Direct contact between stainless- and mild steel should be avoided, because an electrolytic process between these different steel types can lead to increased corrosion.

Therefore a non-ferrous material (like Brass) should be used as a connector between different steel types.



Plastic Pipes

Rising mains of plastic pipes can be used for any type of water, no corrosion is taking place - also none between steel and plastic materials.

Thermoplastic pipes of PVC-U, PVC-HI and HDPE are ideal for rising mains, as long the limitations of these materials are taken into account (see following chapters).

Plastic material as a whole is not yet common by the users and therefore special effort in teaching and training of installation crews and users in the different handling of these materials is essential.

PVC-U Pipes

PVC-U (U = (unplasticized) material is commonly used for borehole casings, screens and many other applications in water supply. Since 20 years, this type of material is also successfully used for rising mains (Afridev).

Material Softness of PVC-U compared to steel is much higher and therefore direct contact between a steel pumprod and the wall of the rising main would lead to perforation of the rising main pipe after a short period of operation. Therefore centralisers of Nitrile rubber are used to keep the pumprod in the centre of the rising main, to avoid scratching.



Elongation under Load is another important characteristic of PVC-U pipes that needs to be addressed. If the rising main is hanging freely in the casing, it will stretch with the increasing load of the water column. The load of the water column in the rising main will increase and decrease at every pump stroke applied directly by the pump handle. This makes the pump end bouncing up and down at the same interval as the pump handle of a reciprocating pump is operated. This oscillating movement (up and down) of the rising main increases the stress at the pipe joints and therefore the designer of the pump will give exact data until what depth the pump can be used (Afridev = 45 m). This constant movement of the rising main requires also a centraliser of Nitrile rubber between the riser pipes and the casing pipes.

If the elongation of the rising main is eliminated by a supported from the end of the borehole, the PVC-U rising main can be used in much deeper applications (Afridev with Bottom Support = 80 m).

Connecting of PVC-U pipes:

- PVC-U pipes that are not under tensile stress can easily be connected by threads (see also casings).
- If PVC-U pipes are used for rising mains, especially those who are hung from the pump head, should be connected by solvent cemented joints.

Note: Material quality of PVC-U pipes is important (consult pump specifications). Jointing procedure of PVC-U riser pipes has to be followed (consult installation manual).

PVC-HI Pipes

For rising mains made of PVC-HI (HI = high impact), similar conditions and recommendations are applicable like the one for PVC-U. High impact material is slightly tougher than PVC-U and therefore threaded connections are possible for installation depths until 30 to 35 m.

Note: Threaded sockets made of steel have proven to be a good choice.

HDPE Pipes

Threaded rising main pipes made of HDPE are ideal for handling, but due to its elasticity, this type of material can only be used for a maximal installation depth of 20 m (all types of Direct Action Pumps).

Note:

- This material cannot be glued (or solvent cemented), but ideal for heat jointing.
- To avoid damaging of threads by trying to connect not in a straight manner, a guiding part at the beginning of each socket thread is strongly recommended.



FRP Pipes

Riser pipes made of FRP material (Fibre Reinforced Plastic) are usually composite plastic (mostly Polyester) with several layers of glass fibre windings are resistant to high pressure. Connectors are usually made of threaded polyester mouldings or short pieces of threaded stainless steel incorporated.

Note: These types of pipes are long lasting and sturdy (minimal elongation), but almost as expensive as stainless steel pipes.

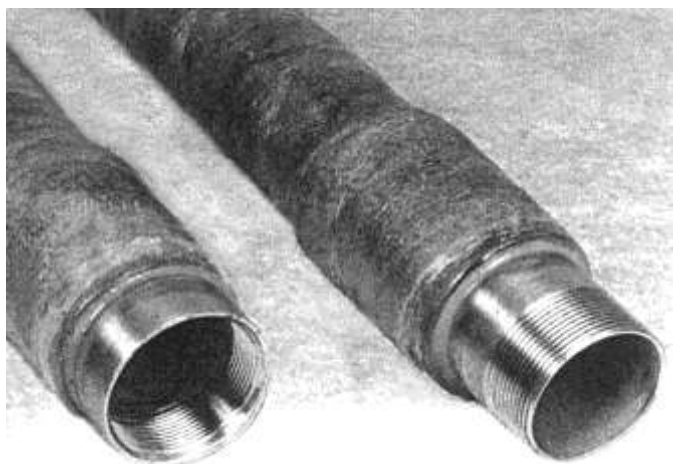

Surface Water

Of the total amount of rainwater that falls upon the land surface of the earth, only a relatively small part is absorbed by the soil. The greater part of it is carried to the sea by streams and rivers or remains stored in natural or artificial lakes and ponds.

Surface water is the most accessible type of water and many types of intake structures have been developed to derive the water from the different sources.

Surface water that can be used for drinking is found in fresh-water lakes and rivers and is in total only about 0.01% of the global water volume. This shows that protection of these sources is extremely important. Surface water like rivers, lakes, ponds etc. is most likely polluted and therefore needs to be treated for being fit for human consumption.

Rivers and lakes are regularly recharged by rain (and to a small amount by glaciers) and they are also recharging the groundwater to some extent.

This chapter includes the following items:

- Rainwater

 - Rainwater Harvesting

 - Rainwater Storage

- Intake Structures for Rivers, Lakes and Dams

 - Direct Intake

 - Infiltration Intake

 - Bottom Intake

 - Side Intake

 - Floating Intake

Rainwater

In most cases, rain water is of good quality and can be used for human consumption without treatment. Rainwater is mostly collected from roofs (roofs with tiles or corrugated iron sheets) and directly lead to a storage place (jar, drum or storage tank). This technique is ideal if there is enough rainfall throughout the year, otherwise large storage facilities are required to keep the collected water safely during the dry season.

Rainwater Harvesting

Catching of rainwater is normally done on roofs or shads covered with tiles, plastic sheet or corrugated iron sheets. The run-off water is then collected at the edge of the roof with a slightly tilted gutter, which leads the water to a storage place (pipe to drum, ferro-cement tank or large ground tank).

Various systems are used to collect the run-off water from the roof. Gutters can be made from plastic pipes, wooden planks covered with plastic foil, but most common are gutters made of bent or folded galvanized iron sheets. It is important that the size of the gutter is large enough and capable to collect all water during heavy rain.

Note:

If the rainfall is starting after a long, dry period, the first flush should be used for cleaning the roof, before water is collected in the storage place.

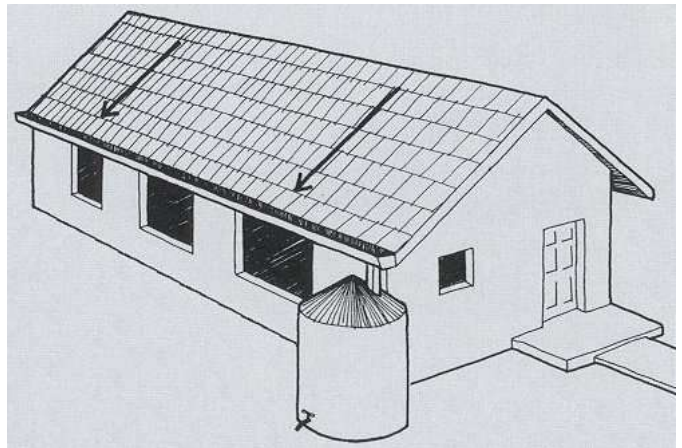

Rainwater Storage

In places where there is regular rainfall, a storage tank besides the house (where the water is caught) is most convenient. Usually these rainwater tanks are equipped with a tap near the ground for easy and hygienic access.

Since these tanks are mostly not large enough to provide all water required, the rainwater collected should be used for human consumption only. For washing, and cleaning, untreated surface water should be used.

In regions where rainwater is scarce, larger ground tanks might be more convenient, so that a larger amount of rainwater could be stored. Safely stored water (without access of sunlight) will improve its quality during storage.

Special care has to be taken when water is drawn from the ground tank, in order not to contaminate the stored water. A simple handpump would secure the daily collection of drinking water.



Intake Structures for Rivers, Lakes and Dams

The most common intake structures for deriving water from the available source are listed and explained below.

- 4.2.2.1 Direct Intake from rivers, lakes, ponds,
- 4.2.2.2 Infiltration Intake from rivers, lakes, ponds,
- 4.2.2.3 Bottom Intake from rivers,
- 4.2.2.4 Side Intake from rivers,
- 4.2.2.5 Floating Intake from rivers, lakes, ponds,

Direct Intake

If a direct intake is made in a lake or pond or a slow moving river, the strainer of the intake pipe should be fixed to a post or pile. It has to be made sure that the strainer is not placed too low (to avoid clogging by mud) or too high (to avoid sucking of air).

In a shallow stream or pond where the strainer is not sufficiently covered by at least 10 cm (4") of water, a pit should be dug and lined with larger stones. After placing the strainer at the lowest part, it has to be covered by coarse gravel and topped by a layer of heavy stones.

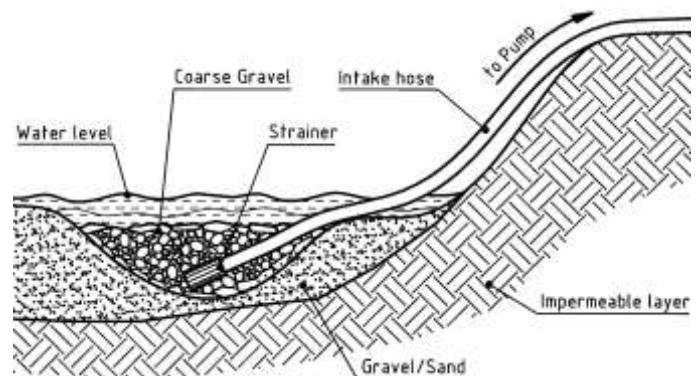
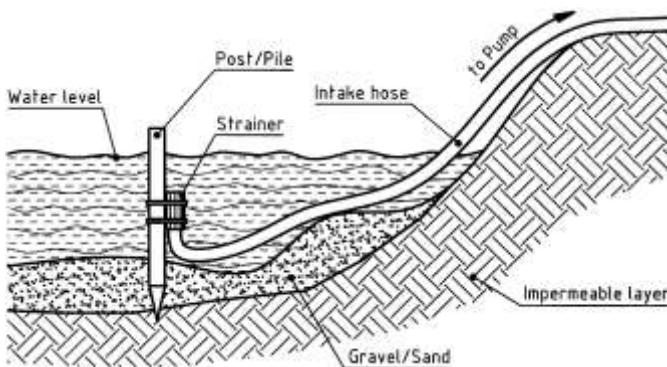

Infiltration Intake

Infiltration Intakes near the banks of a river or at a lake shore are quite common. The principle of this intake type is to use the gravel and sand of the river bed or lake ground to clean the water before it is pumped for consumption or further treatment. The water that passes the large gravel and sand banks will be cleaned similarly as in a roughing or sand filter (see drawing).

Many different types of Infiltration Intakes are existing, depending on the situation of the water source. If no sand and gravel layers at the ground of the water source are existing (like in ponds) it is advisable to design the intake as such that the water is directed by a pipe to a sand filter, before it is pumped for consumption.

Another system is the building of a “Sand Storage Dam” from which water can be collected by a pump.

A further opportunity is to design and place the filtration unit directly at the ground of a pond or at the side of a river bank. Special attention has to be taken for securing the filtration unit in a river bed, in order no to get damaged by logs or strong current if the river is swollen after heavy rain. Placing of large rocks before or after the filter might be sufficient.

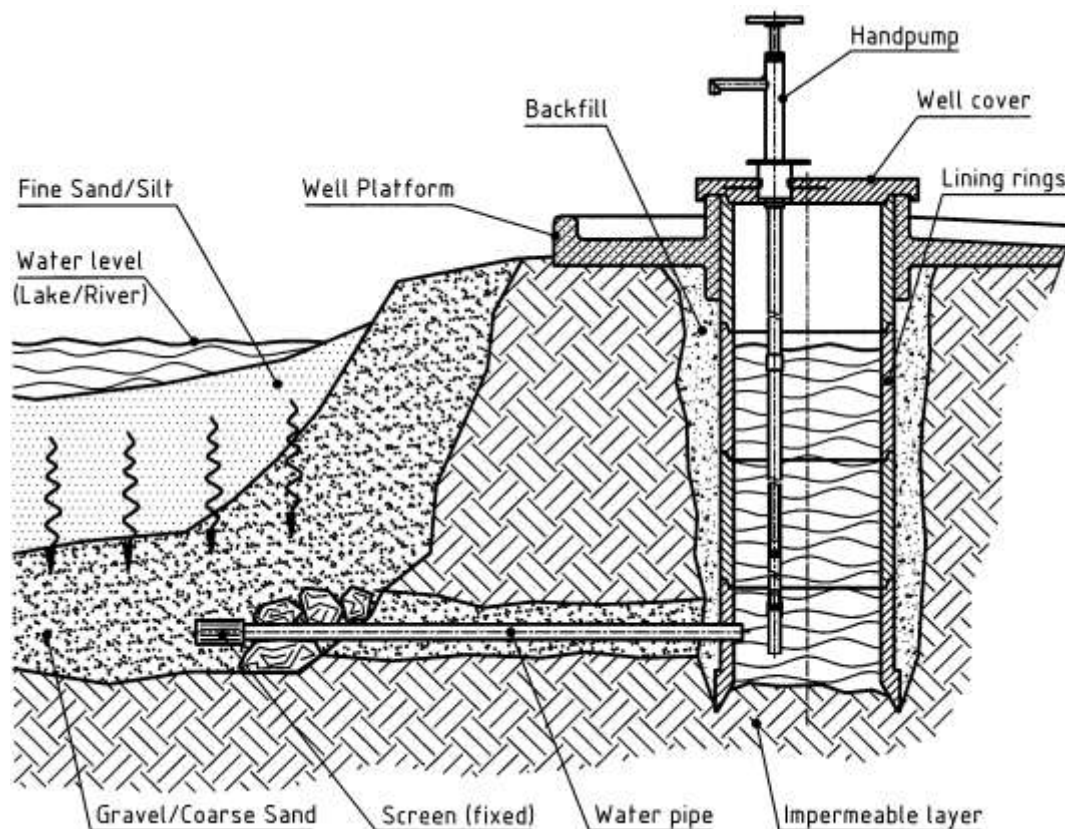

Bottom Intake

For smaller streams, the water can be diverted directly from the stream into a channel that leads the water to a treatment plant (sedimentation tank, sand filter etc.).

A concrete weir needs to be built and the river banks secured with side walls. Usually the side walls are narrowed at the weir, so that the water is flowing faster and its flow is laminar.

After the highest point of the weir, a water channel is built (90 ° to the flow of the water) and covered with a heavy built gutter. The spacing of the gutter bars has to be made as such that the water can easily flow into the channel, but large or medium stones cannot pass. The speed of the water is usually enough to keep the gutter clear of stones and other debris carried by the water.



Some bottom intake designs are providing a cleaning channel before the gutter, so that larger rocks and stones get trapped.

Regular cleaning of water channels (and cleaning channels) is essential.

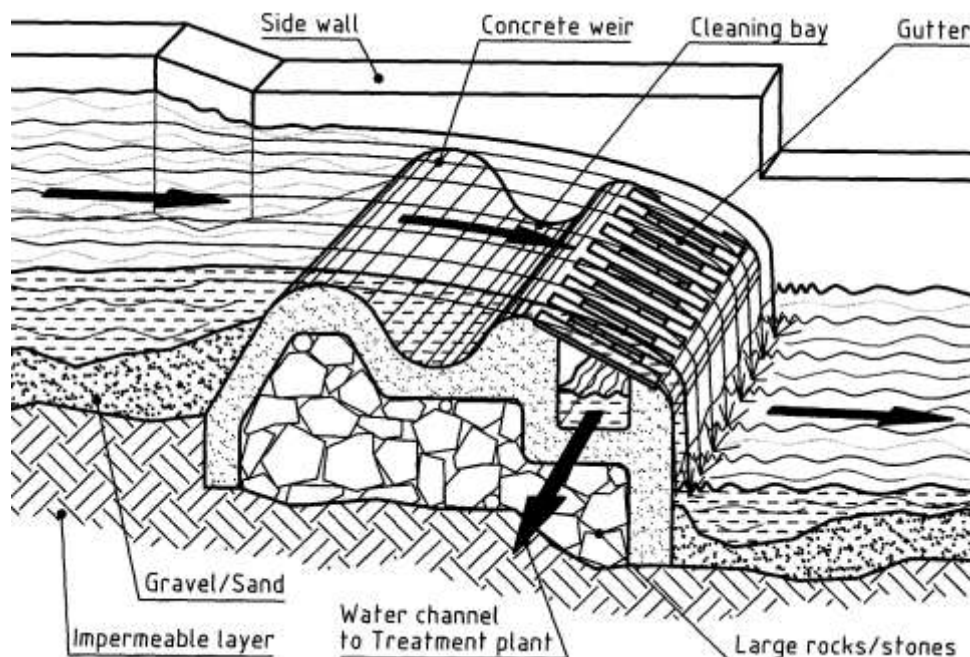

Side Intake

Side intakes are mostly suitable to be built on one side of a stream, preferably on a straight section with a sturdy bank (rocks and stones).

For easy catchment of water a weir is built, so that the water level at the intake is more or less steady and a constant flow is achieved.

To avoid that larger stones and debris are blocking the water channel after the intake point, a large inclined gutter (or screen) made of narrowly spaced steel bars.

Following the upper end of the steel bars, a special channel is fitted, in which all debris will be collected when the gutter is cleaned from the top by a rake.



Cleaning the gutter at regular intervals, especially after every heavy rainfall is essential, so that the water flow to the intake is not blocked by logs and other debris.

Water collected by the side intake can be lifted to a higher point by a motorized pump or can be lead by a channel (by gravity) to a treatment plant.

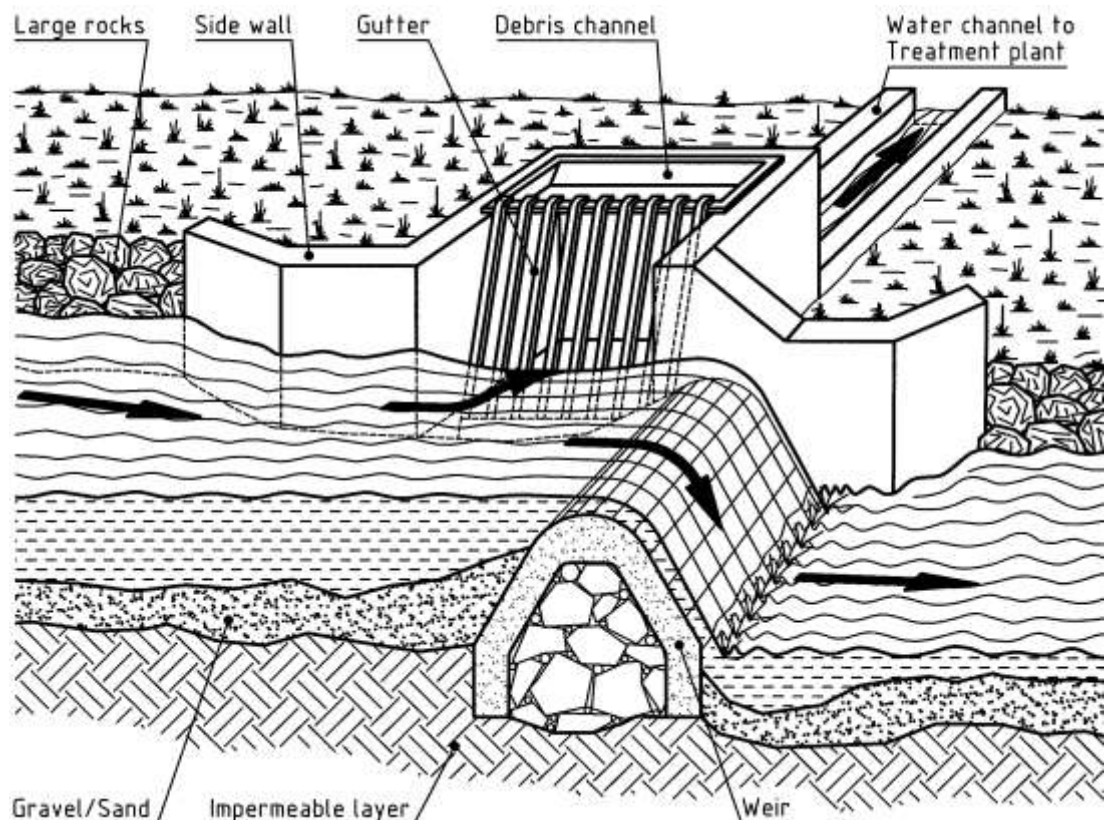

Floating Intake

In swiftly flowing streams with frequent changing water levels or where intake strainers may be covered with debris, sand or silt, a floating intake is ideal. It can be fixed by ropes from the stream banks or by a heavy anchor at a deep part of the stream, allowing enough slack for movement of the float. If support lines are used to secure the float to the banks, the position of the float can be altered to correspond to changes in depths by manipulating of the lines.

The biggest advantage of floating intakes is the ease with which the strainer can be adjusted vertically.

In lakes or ponds with a much polluted shore site or heavy growth of water plants, a floating intake might be a good solution.

